

TKR

Extremely quiet and low-vibration for highly dynamic applications*

- Long service life
- Ideal for highly dynamic applications
- High lateral stability
- Suitable for clean rooms
- Simple shortening and extension due to modular design

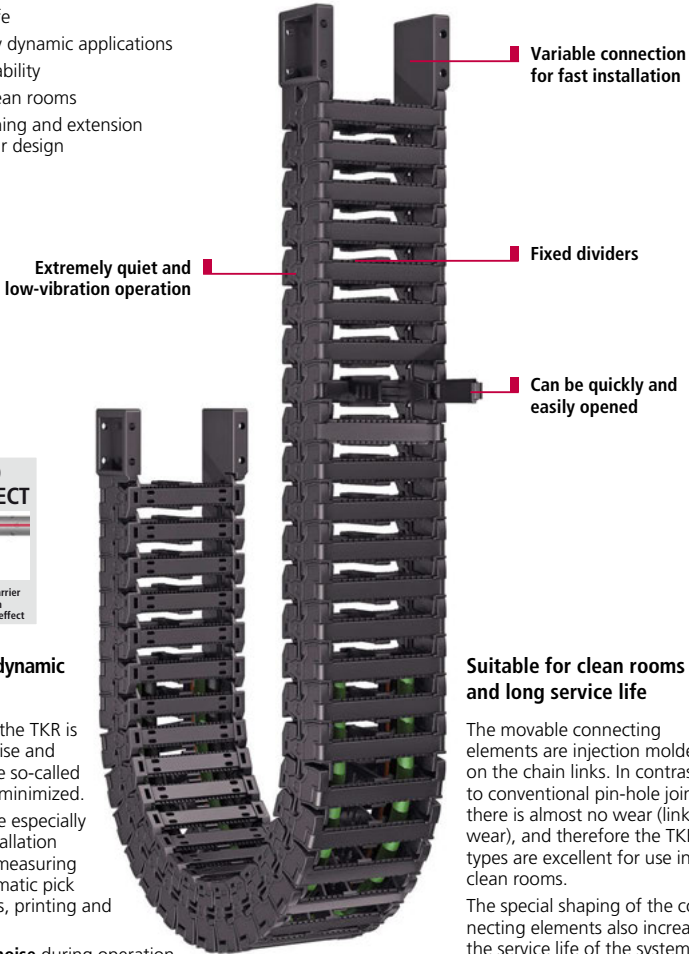

Inside height



Inside widths

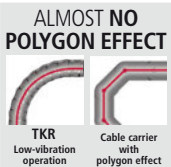

Ideal for highly dynamic applications

The operation of the TKR is extremely low-noise and low-vibration. The so-called polygon effect is minimized. Optimum uses are especially handling and installation systems, robots, measuring equipment, automatic pick and place systems, printing and textile machines.

Due to their **low noise** during operation, the TKR types are optimally suitable for applications with **low-vibration linear drives**.

Suitable for clean rooms and long service life

The movable connecting elements are injection molded on the chain links. In contrast to conventional pin-hole joints, there is almost no wear (link wear), and therefore the TKR types are excellent for use in clean rooms.

The special shaping of the connecting elements also increases the service life of the system.

kabelschlepp.de

Font: +49 2762 4003-0

OnlineEngineer.de
TKR and KABELSCHLEPP are registered trademarks of Cable Carrier Engineering



Ideal for highly dynamic applications



Universal connectors (UMB) for connection above, below or at the front



Injection molded connecting elements

* Some features can be different for certain types for design reasons. Our specialists are happy to advise you.

TKR 0150, 0200, 0260 and 0280

Solid plastic cable carrier

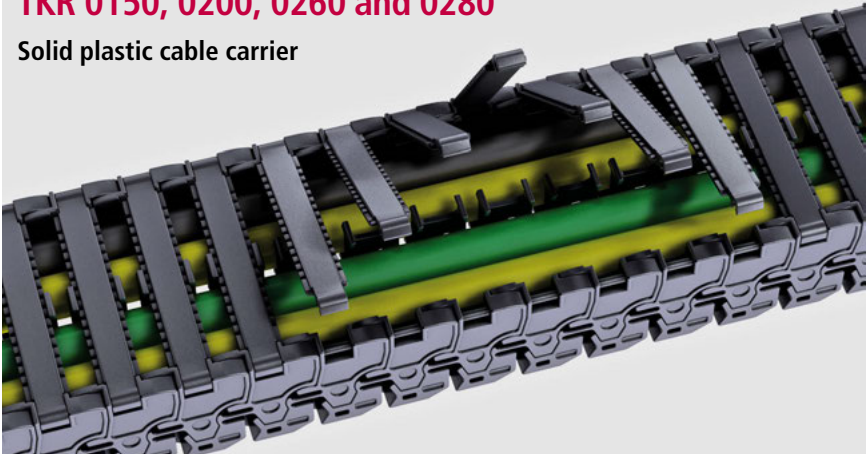

Inside height



Inside widths



kabelschlepp.de

Type	h _i	B _i	Maximum travel length unsupported in m	Dynamics of unsupported arrangement		Page
				Travel speed* v _{max} in m/s	Travel acceleration* a _{max} in m/s ²	
TKR 0150	22	20-60	1.77	5	200**	227
TKR 0200	28	40-120	2.76	5	200**	227
TKR 0260	40	50-200	3.95	5	200**	227
TKR 0280	52	50-200	4.94	5	200**	227

* Possible maximum values: Please contact us.

** At values > 20 m/s² please contact us – we are happy to advise you.

Dimensions in mm

Fon: +49 2762 4003-0

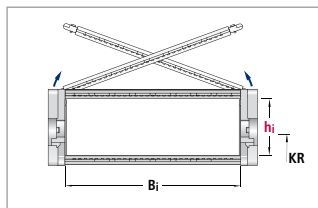
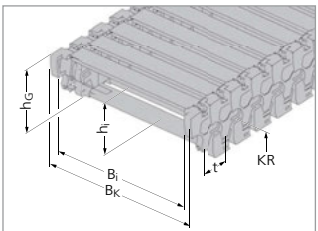

Dimensions and intrinsic weight

Type	h _i	h _G	Inside width B _i Intrinsic chain weight						B _k
			20	40	60	80	100	120	
TKR 0150	22	27,5	0,3	0,4	0,5	–	–	–	B _i + 14
			–	–	–	–	–	–	
TKR 0200	28	37,0	0,6	0,6	0,7	0,8	0,9	1,0	B _i + 16
			–	–	–	–	–	–	
TKR 0260	40	54,0	1,5	1,7	1,9	2,1	2,3	2,7	B _i + 26
			–	–	–	–	–	–	
TKR 0280	52	66,0	2,0	2,2	2,4	2,6	2,8	3,2	B _i + 30
			–	–	–	–	–	–	

Use our free project planning service.

TKR 0150, 0200, 0260 and 0280

Bend radius and pitch

Type	Bend radii KR mm			
TKR 0150	40	50	75	–
TKR 0200	55	75	95	150
TKR 0260	75	100	125	150
TKR 0280	75	100	150	200

Pitch:

TKR 0150: t = 15 mm

TKR 0200: t = 20 mm

TKR 0260: t = 26 mm

TKR 0280: t = 28 mm

Inside height



Inside widths



Load diagram

for unsupported length L_f depending on the additional load

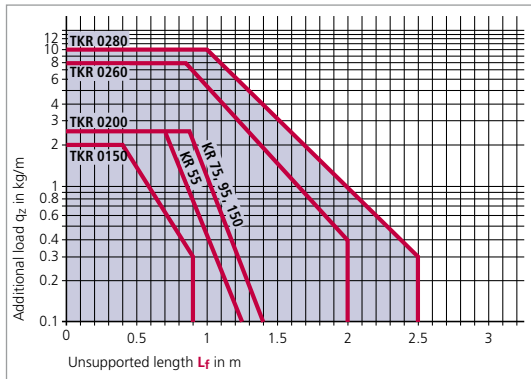

Unsupported length L_f

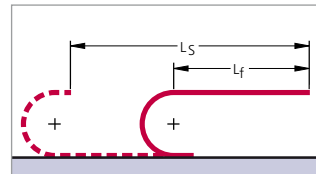

In the case of longer travel lengths, sag of the cable carriers is technically permissible depending on the application.

We are at your service to advise on these applications.

kabelschlepp.de

Font: +49 2762 4003-0

Example of ordering

Cable Carrier	Divider system	Connection
TKR 0200 · 100 · 95 · 800	TS 0 / 3	FA/MA
Type	Divider system	Connection
Inside width B_i in mm	Number of dividers n_T	Fixed point/Driver
Bend radius KR in mm		
Chain length L_k in mm (without connection)		

TKR 0150: Chain links can only be ordered in even numbers.

Ordering divider systems:

Please state the designation of the divider system (TS 0, TS 1 ...) and the number of dividers. Possibly attach a sketch with the dimensions.

TKR 0150, 0200, 0260 and 0280

Fixing the dividers

In the standard version, dividers or the complete divider system (dividers with height separation) can be moved in the cross section. (Mounting version A)

Fixed dividers are available for applications with transverse accelerations and where the carrier is rotated through 90° (Version B).

If the fixed installation version is desired, please state this on the order.

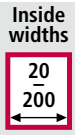

Version A (Standard)

Movable divider

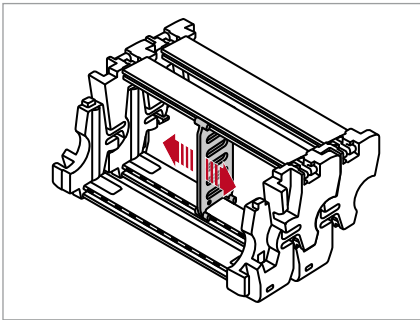

Version B

Fixed divider

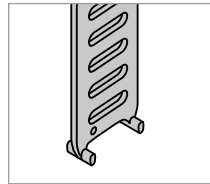
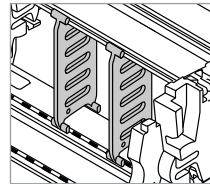

■ Locking profile in the crossbar

■ Divider with arresting cams

kabelschlepp.de

Divider system TS 0

Type	h _i mm	Version A			Version B			
		S _T mm	a _T min mm	a _x min mm	S _T mm	a _T min mm	a _x min mm	a _x section mm
0150	22	2.0	5.0	6.0	2.0	6.0	6.0	2.0
0200	28	2.0	4.0	8.0	2.0	4.0/5.0/6.0*	8.0	4.0
0260	40	2.4	3.0	8.0	2.4	5.5/6.0/7.0**	8.0	4.0
0280	52	2.4	3.0	8.0	2.4	5.5/6.0/7.0**	8.0	4.0

* a_T min = 4.0 mm for B_i = 40, 80
 a_T min = 5.0 mm for B_i = 50
 a_T min = 6.0 mm for B_i = 60, 100, 120

** a_T min = 5.5 mm for B_i = 75
 a_T min = 6.0 mm for B_i = 100
 a_T min = 7.0 mm for B_i = 150

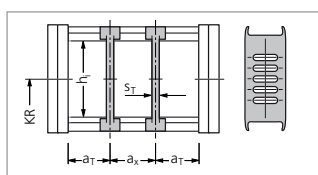
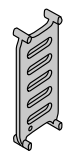
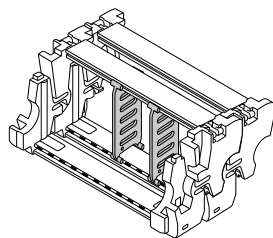

Use our free project planning service.

TKR 0150, 0200, 0260 and 0280

Divider system TS 1

with continuous height subdivision made of aluminum (TKR 0150, 0260, 0280)
or plastic (TKR 0200)

Type	Version A				Version B				S_H mm	h_1 mm	h_2 mm
	h_i mm	S_T mm	a_T min mm	a_x min mm	S_T mm	a_T min mm	a_x min mm	a_x section mm			
0260	40	2.4	3.0	8.0	2.4	5.5/6.0/7.0**	8.0	4.0	2.6	14	28
0200	28	2.0	4.0	8.0	2.0	4.0/5.0/6.0*	8.0	4.0	2.6	11	-
0280	52	2.4	3.0	8.0	2.4	5.5/6.0/7.0**	8.0	4.0	2.6	18	36

* a_T min = 4.0 mm for $B_i = 40, 80$
 a_T min = 5.0 mm for $B_i = 50$
 a_T min = 6.0 mm for $B_i = 60, 100, 120$

** a_T min = 5.5 mm for $B_i = 75$
 a_T min = 6.0 mm for $B_i = 100$
 a_T min = 7.0 mm for $B_i = 150$

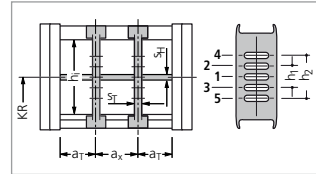
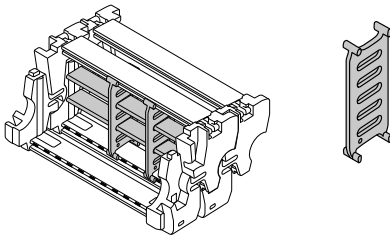

Inside height



Inside widths



kabelschlepp.de

Divider system TS 3

with section subdivision, partitions made of aluminum

Type	Version A				Version B				S_H mm	h_1 mm	h_2 mm
	h_i mm	S_T mm	a_T min mm	a_x min mm	S_T mm	a_T min mm	a_x min mm	a_x section mm			
0260	40	6.0	3.0	26.0	6.0	5.5/6.0/7.0*	28.0	4.0	4.0	14	28
0280	52	6.0	3.0	26.0	6.0	5.5/6.0/7.0*	28.0	4.0	4.0	18	36

* a_T min = 5.5 mm for $B_i = 75$
 a_T min = 7.0 mm for $B_i = 150$

a_T min = 6.0 mm for $B_i = 100$

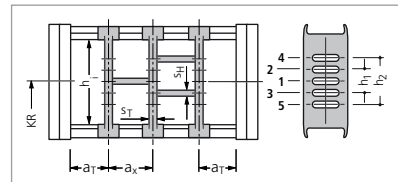

In the standard version, the divider systems are mounted on every second chain link.

Font: +49 2762 4003-0

OnlineEngineer.de
 THE ONLINE ENGINEER
 CABLE CARRIER CONFIGURATOR

Guide channels
 ▶ from page 375

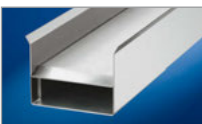

Strain relief devices
 ▶ from page 381



Cables for cable carrier systems
 ▶ from page 438



TKR 0150, 0200, 0260 and 0280

Plastic connectors (Type TKR 0150)

Inside height

Inside widths

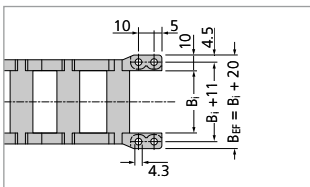
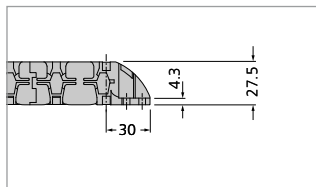

The dimensions of the fixed point and driver connections are identical.

Connection variants (Type TKR 0150)

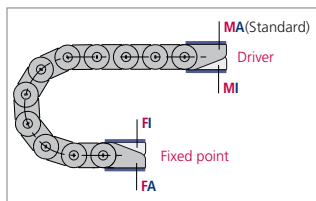

Connection point

- M** – Driver
- F** – Fixed point

Connection type

- A** – Threaded joint outside (standard)
- I** – Threaded joint, inside

In the standard version, the connectors are mounted with the threaded joint outwards (**FA/MA**).

When ordering please specify the desired connection type (see ordering key on page 420).

The connection type can subsequently be altered simply by varying the connectors.

TKR 0150, 0200, 0260 and 0280

UMB (Universal Mounting Brackets) made of plastic (Types TKR 0200, 0260 and 0280)

Universal connectors for connection above, below or at the front.

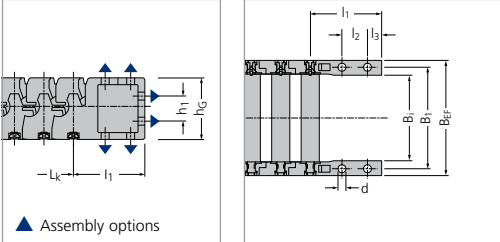

The dimensions of the fixed point and driver connections are identical.

End connectors made of steel plate available on request.

Optional C-rails and strain relief elements for cables can be found on the following pages.

When ordering please specify the connection type FU/MU (see ordering key on page 420).

Type	B _{EF}	b ₁	d	l ₁	l ₂	l ₃	h ₁	h _G
TKR 0200	B _i + 20	B _i + 12	4.3	50/53*	20.0	10.0	15	37
TKR 0260	B _i + 26	B _i + 16	7.0	63	22.5	12.5	22	54
TKR 0280	B _i + 30	B _i + 16	7.0	66/70**	22.5	15.0	22	66

B_{EF} = chain width over connecting piece

Dimensions in mm

* Fixed point = 50 mm, driver = 53 mm

** Fixed point = 66 mm, driver = 70 mm

Inside height

22
—
52

Inside widths

20
—
200

kabelschlepp.de

Font:
+49 2762 4003-0

OnlineEngineer.de
Info- & KABELSCHLEPP
 Cable Center Engineering