

MT Series

Multivariable cable carrier with plastic or aluminum cover system

- Aluminum cover system in 1 mm width sections, plastic cover system in 8 or 16 mm width sections available
- Can be opened quickly on the inside and the outside for cable laying
- Extremely robust due to stable plate construction
- Enclosed stroke system not sensitive to dirt/contamination
- Transmission of forces (tensile and shearing forces) over a large surface area via the optimum link design – according to the “life extending 2 disc principle”
- Standard universal mounting brackets (UMBs)
- Many separation options for the cables
- Highly wear-resistant, replaceable glide shoes available – resulting in minimal wear at high speeds, sliding in the guide channel
- Optionally available with different strain relief systems
- TÜV design approved in accordance with 2PFG 1036/10.97

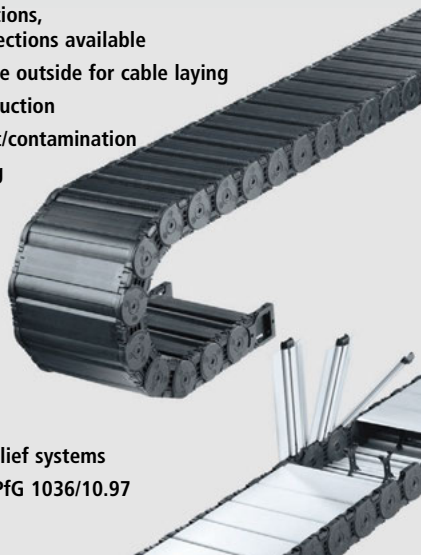

Inside heights



Inside widths



kabelschlepp.de

Type MT with plastic cover system (stay variant RDD)

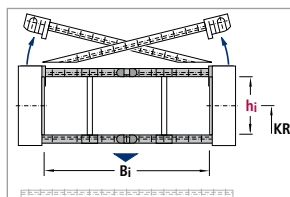

Fon: +49 2762 4003-0

Type	h_i	B_i	Maximum travel length in m	Dynamics of unsupported arrangement		Page
				Travel speed v_{max} in m/s	Travel acceleration a_{max} in m/s ²	
MT 0475	26	24-280	100	10	40	302
MT 0650	38.5	50-258	170	8	35	302
MT 0950	54.5	77-349	230	6	25	302
MT 1250	68.5	103-359	270	5	20	302

Dimensions in mm

Carrier construction and cover system

MT 0475, 0650:

Available in 8 mm width sections.

MT 0950, 1250:

Available in 16 mm width sections.

Opening options

Outside: Simply by levering the cover open (on the right or left). Cover can also be removed

Inside: Simply by turning the cover

MT 0475 is available with a cover that can be levered open to the inside. Please specify when ordering.



Use our free project planning service.

Type MT with aluminum cover system (stay variant RMD)

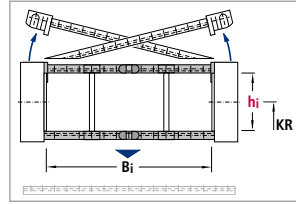

Inside heights

26
-
87

Inside widths

24
-
800

Type	h_i	B_i	Maximum travel length in m	Dynamics of unsupported arrangement		Page
				Travel speed v_{max} in m/s	Travel acceleration a_{max} in m/s^2	
MT 0650	38.5	100-500	170	8	35	302
MT 0950	54.5	100-600	230	6	25	302
MT 1250	68.5	150-800	270	5	20	302
MT 1300	87	100-800	300	5	20	302

Dimensions in mm

Carrier construction and cover system

WIDTHSECTIONS



Available in 1 mm width sections.

Opening options (MT 0650, 0950, 1250)

Outside: Simply by levering the cover open

(on the right or left). Cover can also be removed

Inside: Simply by turning the cover

Opening options (MT 1300)

Inside/Outside: Bolted cover for maximum stability



■ Cover openable (MT 0650, 0950, 1250)

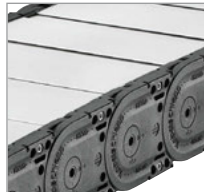

■ Cover bolted (MT 1300)

kabelschlepp.de

Font:
+49 2762 4003-0

Guide channels
➤ from page 375



Strain relief devices
➤ from page 381



Cables for cable carrier systems
➤ from page 438



Types MT 0475, 0650, 0950, 1250 and 1300

Dimensions and intrinsic chain weight

Plastic cover systems (stay variant RDD)

Type	Stay variant	h _i	h _G	B _i min	q _k min	B _i max	q _k max	B _k	Width section
MT 0475	RDD	26	39	24	0.9	280	4.4	B _i + 17	8
MT 0650	RDD	38.5	57	50	2.4	258	3.7	B _i + 34	8
MT 0950	RDD	54.5	80	77	4.3	349	7.7	B _i + 39	16
MT 1250	RDD	68.5	96	103	5.7	359	8.9	B _i + 45	16

Dimensions in mm/Weights in kg/m

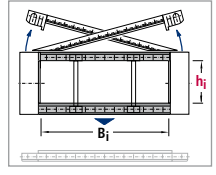

Inside heights



Inside widths



Aluminum cover systems (stay variant RMD)

Type	Stay variant	h _i	h _G	B _i min	q _k min	B _i max	q _k max	B _k
MT 0475	RMD	26	39	24	0.9	180	4.5	B _i + 17
MT 0650	RMD	38.5	57	100	3.3	500	9.7	B _i + 34
MT 0950	RMD	54.5	80	100	5.5	600	16.2	B _i + 39
MT 1250	RMD	68.5	96	150	9.0	800	26.0	B _i + 45
MT 1300	RMD	87	120	100	8.8	800	27.4	B _i + 50

Dimensions in mm/Weights in kg/m

WIDTH SECTIONS
1 mm

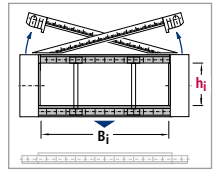

kabelschlepp.de

Bend radius and pitch

Type	Bend radii KR mm							
MT 0475	75	100	130	160	200	250	300	-
MT 0650	95*	115	145	175	220	260	275	300
MT 0950	140*	170*	200	260	290	320	380	-
MT 1250	220*	260	300	340	380	500	-	-
MT 1300	240	280	320	360	400	500	-	-

* not for aluminum cover system RMD

Pitch:
 MT 0475: t = 47.5 mm
 MT 0650: t = 65 mm
 MT 0950: t = 95 mm
 MT 1250: t = 125 mm
 MT 1300: t = 130 mm

Load diagram

for unsupported length L_f depending on the additional load

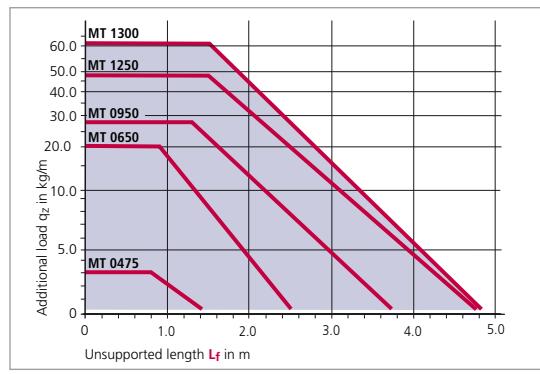

Unsupported length L_f

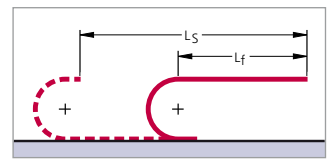

In the case of longer travel lengths, sag of the cable carriers is technically permissible depending on the application. In a gliding arrangement, even longer travel lengths are possible (see page 375). We are at your service to advise on these applications.

Fon: +49 2762 4003-0

Use our free project planning service.

Example of ordering

Cable carrier: **MT 0950** . **450** . **RMD** . **290** - **2850**

Type: Inside width B_i in mm Stay variant Bend radius KR in mm Chain length L_k in mm (without connection)

Divider system: **TS 0** / **4**

Connection: **FU/MU**

Divider system: Divider system Number of dividers n_T Connection: Fixed point/Driver

Ordering divider systems: Please state the designation of the divider system (TS 0, TS 1 ...) and the number of dividers. Possibly attach a sketch with the dimensions.

Types MT 0475, 0650, 0950, 1250 and 1300

Divider system TS 0

Type	Stay variant	h _j mm	S _T mm	a _T min mm	a _x min mm	a _x section mm
MT 0475	RDD	26	2.8	12	8	8
MT 0650	RDD	38.5	4.2	13	16	8
MT 0650	RMD	38.5	3	16	13	–
MT 0950	RDD	54.5	6	22.5	16	16
MT 0950	RMD	54.5	4	7	14	–
MT 1250	RDD	68.5	8	19.5	16	16
MT 1250	RMD	68.5	5	10	20	–
MT 1300	RMD	87	5	7.5	15	5

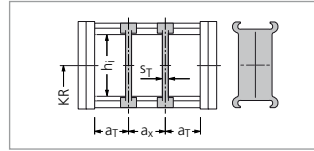

In the standard version, the divider systems are mounted on every second chain link.

Inside heights

26
–
87

Inside widths

24
–
800

With plastic cover systems (RDD), the dividers are fixed in the cross-section (at intervals of a_x-section). With aluminum cover systems (RMD), the dividers can be moved.

Divider system TS 1 with continuous height subdivision made of aluminum

Type	Stay variant	h _j mm	S _T mm	a _T min mm	a _x min mm	a _x section mm	S _H mm	h ₁ mm	h ₂ mm	h ₃ mm	h ₄ mm
MT 0475	RDD	26	2.8	12	8	8	2.4	15	–	–	–
MT 0650	RDD	38.5	4.2	13	16	8	4	10	22	–	–
MT 0650	RMD	38.5	3	16	13	–	4	–	–	–	–
MT 0950	RDD	54.5	6	22.5	16	16	4	22	–	–	–
MT 1250	RDD	68.5	8	19.5	32	16	4	32	–	–	–
MT 1300	RMD	87	5	7.5	15	–	4	14	28	42	56

With plastic cover systems (RDD), the dividers are fixed in the cross-section (at intervals of a_x-section). With aluminum cover systems (RMD), the dividers can be moved.

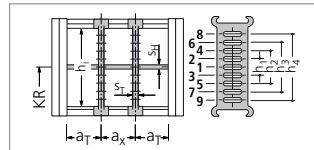

In the standard version, the divider systems are mounted on every second chain link.

Divider system TS 2 with grid subdivision made of aluminum (1 mm grid)

Type	Stay-variant	h _j mm	S _T mm	a _T min mm	a _x min mm	a _x section mm	S _H mm	h ₁ mm	h ₂ mm	h ₃ mm
MT 0475	RDD	26	2.8	12	8	8	2.4	15	–	–
MT 0650	RDD	38.5	4.2	13	16	8	4	10	–	–
MT 0950	RMD	54	6	7	16	–	4	15	30	–
MT 1250	RMD	69	6	7	16	–	4	15	30	45

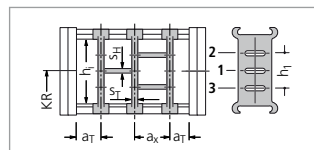

In the standard version, the divider systems are mounted on every second chain link.

Divider system TS 3 can be found on the following page.

kabelschlepp.de

Fon: +49 2762 4003-0

OnlineEngineer.de
TSUBAKI KABELSCHLEPP
 Cable carrier configurations

Types MT 0475, 0650, 0950, 1250 and 1300

Divider system TS 3 with section subdivision, partitions made of plastic

Inside heights



Inside widths



Type	Stay variant	h ₁ mm	S _T mm	a _T min mm	a _x min mm	S _H mm	h ₁ mm	h ₂ mm	h ₃ mm	h ₄ mm
MT 0950	RDD	54.5	8	6.5	16*	4	14	28	42	–
MT 1250	RDD	68.5	8	4	16*	4	14	28	42	56
MT 1300	RMD	87	8	7.5	16*	4	14	28	42	56

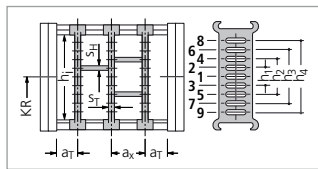

* When using plastic partitions

With plastic cover systems (RDD), the dividers are fixed in the cross-section. In the standard version, the divider systems are mounted on every second chain link.

Dimensions of plastic partitions for TS 3

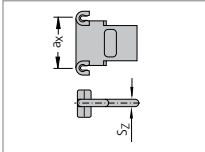

S _Z	a _x (center-to-center distance, dividers)									
4	16	18*	23*	28*	32	33*	38*	43*	48	58*
	64	68*	78*	80	88*	96	112	128	144	160
	176	192	208	–	–	–	–	–	–	–

* only MT 1300

Dimensions in mm

Aluminum partitions in 1 mm width sections are also available.

When using partitions with a_x > 112 mm there should be an additional central support with a twin divider (S_T = 4 mm).

Twin dividers are designed for subsequent fitting in the partition system.

kabelschlepp.de

Connectors of plastic/steel – Type MT 0475

End connector of steel plate

Screwable strain relief of aluminum on inquiry.

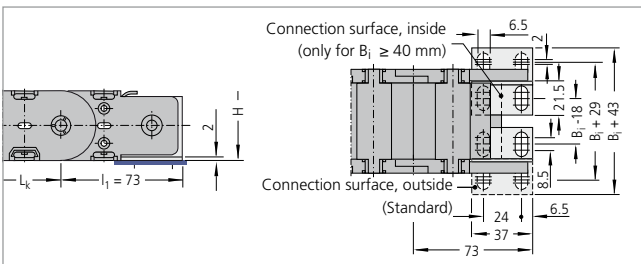

The dimensions of the fixed point and driver connections are identical.

Connection variants – Type MT 0475

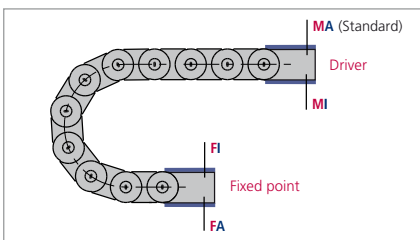

Connection point

- M – Driver
- F – Fixed point

Connection type

- A – Threaded joint outside (standard)
- I – Threaded joint inside

In the standard version, the connectors are mounted with the threaded joint outwards (FA/MA). When ordering please specify the desired connection type (see ordering key on page 419). The connection type can subsequently be altered.

Glide shoes and "life extending 2 disc principle" – see page 308.

Fon: +49 2762 4003-0

Use our free project planning service.

Types MT 0475, 0650, 0950, 1250 and 1300

UMB-connectors of aluminum – Type MT 0650

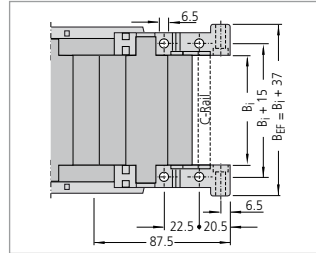
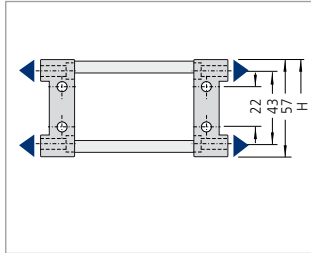
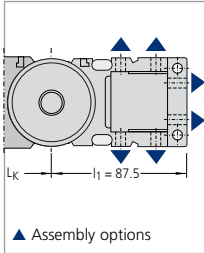

Inside heights

26
-
87

Inside widths

24
-
800

The dimensions of the fixed point and driver connections are identical.

End connectors of steel plate available on inquiry.

Optional C-rails and strain relief elements for cables can be found on the following pages.

When ordering please specify the connection type FU/MU (see ordering key on page 419).



UMB-connectors of aluminum – Types MT 0950, 1250

UMB-connectors of plastic – Type MT 1300

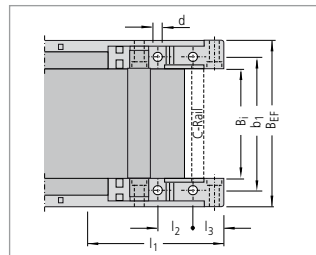
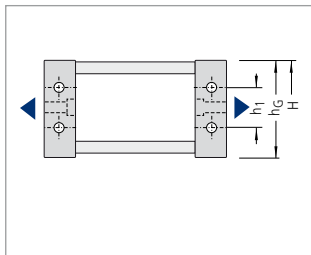
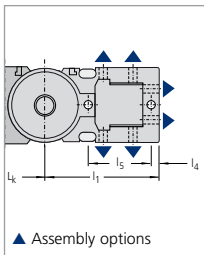

The dimensions of the fixed point and driver connections are identical.

End connectors of steel plate available on inquiry.

Optional C-rails and strain relief elements for cables can be found on the following pages.

When ordering please specify the connection type FU/MU (see ordering key on page 419).

Type	B _{EF}	b ₁	d	l ₁	l ₂	l ₃	l ₄	l ₅	h ₁	h _g
MT 0950	B _i + 44	B _i + 24.5	8,5	136	35	24.5	8.5	80	45	80
MT 1250	B _i + 51	B _i + 28	11	168	35	31	10.5	94.5	45	96
MT 1300	B _i + 50	B _i + 29	11	158	35	20	-	-	66	120

B_{EF} = Chain width over connector

Dimensions in mm

kabelschlepp.de

Fon: +49 2762 4003-0

OnlineEngineer.de
The online engineering
CAD center for everyone

Types MT 0475, 0650, 0950, 1250 and 1300

Strain relief devices

Both-sided strain relief combs made of plastic (MT 0650)

The cables can be fixed securely and simply using the **optional strain relief combs**.

The strain relief combs are installed between the UMBs, and do not need to be bolted on separately or mounted on a C-Rail.

Please state on the order whether strain relief combs are needed.

Inside
heights



Inside
widths



■ Universal mounting bracket with strain relief comb



■ Both-sided strain relief comb

kabelschlepp.de



■ Fixing in the UMB.

Type	B _i mm	n _z
MT 0650	50	3
MT 0650	75	5
MT 0650	95	7
MT 0650	100	7
MT 0650	115	8
MT 0650	120	9
MT 0650	125	9
MT 0650	145	11
MT 0650	150	11
MT 0650	170	13
MT 0650	175	13
MT 0650	195	15
MT 0650	200	15
MT 0650	225*	17
MT 0650	250*	19

n_z = Number of teeth on one side of the comb

* on request

Fon:
+49 2762 4003-0

Use our free
project planning service.

Types MT 0475, 0650, 0950, 1250 and 1300

Strain relief devices

C-rails for LineFix bracket clamps, SZL strain reliefs and clamps

The optional C-rails are fixed by means of the universal mounting brackets and do not have to be screwed separately.

Please state in your order whether C-rails are needed.



■ Universal mounting bracket with C-rail

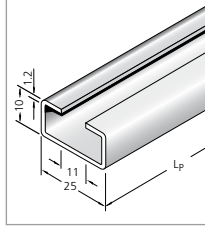

■ **MT 0650:**
Integratable C-rail
25 x 10 mm,
slit width 11 mm,
material steel,
Item-No. 3931

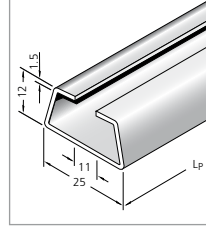

■ **MT 1300:**
Integratable C-rail
25 x 12 mm,
slit width 11 mm,
material steel,
Item-No. 3934

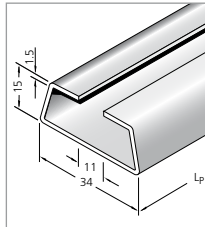

■ **MT 0950, 1250 and 1300:**
Integratable C-rail
34 x 15 mm,
slit width 11 mm,
material steel,
Item-No. 3935

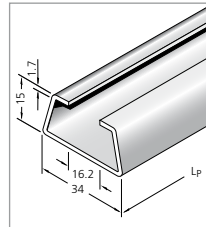

■ **MT 0950, 1250 and 1300:**
Integratable C-rail
34 x 15 mm,
slit width 16 – 17 mm,
material aluminum,
Item-No. 3926,
material steel,
Item-No. 3932

Our LineFix strain reliefs are optimally suited for the C-rails. (LineFix bracket clamps and other strain relief devices – see Accessories chapter, from page 381 onwards).



■ C-rail with LineFix strain relief

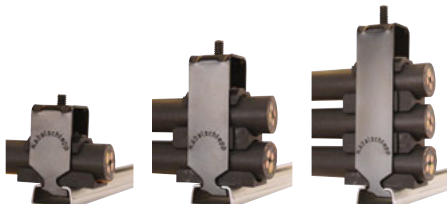

Inside heights



Inside widths



kabelschlepp.de

Font: +49 2762 4003-0

OnlineEngineer.de
The online engineer
Cable Carrier Configuration

Types MT 0475, 0650, 0950, 1250 and 1300

Fixing the dividers in 5 mm steps – Type MT 1300

In the standard version, dividers or the complete divider system (dividers with height separation) can be moved in the cross section.

Fixing profiles can be used to fix the dividers or complete divider systems. Also best suited for applications where the carrier is rotated through 90° with extreme transverse accelerations (fixable dividers for stay variant RMD).

If the fixed installation version is required, please state this when placing your order.

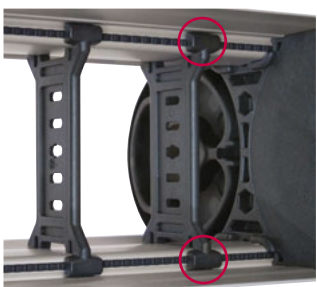

■ Secure seating of the dividers due to fixing on both sides.



■ The fixing profiles are simply pushed into the cover (RMD).

Inside heights
26
87

Inside widths
24
800

kabelschlepp.de

Fon: +49 2762 4003-0

Gliding elements – the economical solution for gliding applications

Replaceable glide shoes made of plastic

To extend the life of cable carriers in gliding operations KABELSCHLEPP supplies detachable, exchangeable glide shoes.

Replaceable glide shoes are a very economical solution. When wear occurs only the glide shoes are replaced, and not the complete cable carrier. For travel speeds > 2.5 m/s and large additional loads, a highly wear-resistant special material is used.

For types MT 0950 and MT 1250 **OFFROAD glide shoes** with 80 % greater wear volumes are also available. We recommend their use in extreme environmental conditions (with particularly abrasive materials such as e. g. sand, dust, corundum).



! By means of a positive snap connection, the glide shoes sit firmly on the chain link.

Chain height with glide shoes:

MT 0475:	$h_{G'} = h_G + 2.5 = 41.5$
MT 0650:	$h_{G'} = h_G + 3.2 = 60.2$
MT 0950:	$h_{G'} = h_G + 3.5 = 83.5$
MT 1250:	$h_{G'} = h_G + 3.5 = 99.5$
MT 1300:	$h_{G'} = h_G + 7.0 = 127.0$

In the case of the type MT 0475, with the bend radius $KR = 75$ mm no glide shoes can be used.

Dimensions in mm

Minimized hinge wear owing to the "life extending 2 disc principle"

In the M Series*, the push and pull forces are transmitted via the optimum link design for this purpose.

As a result link wear is reduced to a minimum and the life of the cable carrier is considerably lengthened.

* not for type 0320

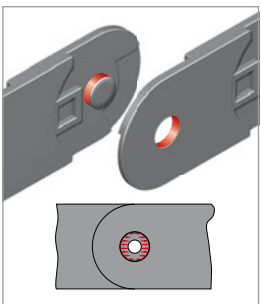

■ Force transmission with a pin-hole joint

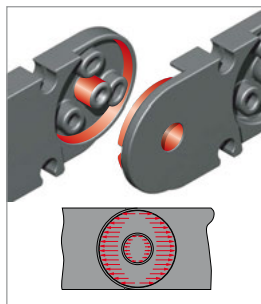

■ Force transmission with the "life extending 2 disc principle"

Use our free project planning service.

Notes

Inside heights



Inside widths



kabelschlepp.de

Font:
+49 2762 4003-0

OnlineEngineer.de
The Online Engineer
Cable Center Configuration

