

CATALOGO GENERALE

RIDUTTORI EPICICLOIDALI

GENERAL CATALOGUE

PLANETARY REDUCTION GEARS

GESAMTKATALOG

PLANETENGETRIEBE

CATALOGUE GÉNÉRAL

REDUCTEURS EPICYCLOIDAUX

CATÁLOGO GENERAL

REDUCTORES EPICICLOIDALES

CATÁLOGO GERAL

REDUTORES EPICICLOIDAIS

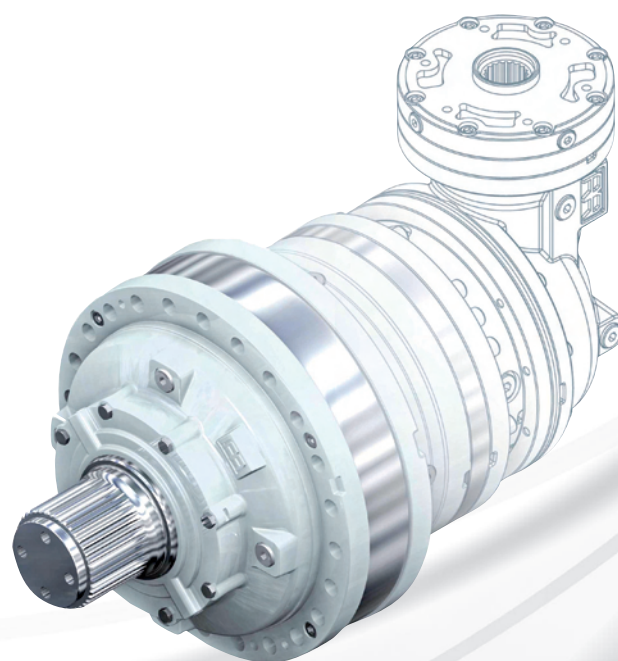

RR2500 ÷ RR55000

RRPLUS 

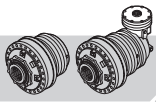

INDICE	INDEX	INHALTSVERZEICHNIS	
A Informazioni generali	<i>General information</i>	Allgemeine Informationen	
1 SIMBOLOGIA	1 <i>SYMBOLS</i>	1 VERWENDETE SYMBOLE	A-2
2 IDENTIFICAZIONE DEL PRODOTTO	2 <i>PRODUCT IDENTIFICATION</i>	2 PRODUKTKENNZEICHNUNG	A-4
3 CARATTERISTICHE TECNICHE	3 <i>TECHNICAL CHARACTERISTICS</i>	3 TECHNISCHE BESCHREIBUNG	A-8
4 SELEZIONE DEI RIDUTTORI	4 <i>SELECTING THE REDUCTION GEARS</i>	4 AUSWAHL VOM PLANETENGE-TRIEBE	A-24
5 VERIFICHE	5 <i>CHECKS</i>	5 KONTROLLEN	A-30
6 LUBRIFICAZIONE	6 <i>LUBRICATION</i>	6 SCHMIERUNG	A-40
7 IMBALLO, MOVIMENTAZIONE E STOCCAGGIO	7 <i>PACKING, HANDLING AND STORING</i>	7 VERPACKUNG, TRANSPORT UND LAGERUNG	A-70
B Dati tecnici e dimensionali	<i>Technical and size data</i>	Technische daten und Abmessungen	
8 COPPIE NOMINALI	8 <i>NOMINAL TORQUES</i>	8 NENNDREHMOMENTE	B-3
RR2500	RR2500	RR2500	B-4
RR3200	RR3200	RR3200	B-20
RR4000	RR4000	RR4000	B-36
RR5200	RR5200	RR5200	B-52
RR6500	RR6500	RR6500	B-68
RR8000	RR8000	RR8000	B-84
RR10000	RR10000	RR10000	B-100
RR15000	RR15000	RR15000	B-116
RR20000	RR20000	RR20000	B-126
RR25000	RR25000	RR25000	B-134
RR30000	RR30000	RR30000	B-142
RR40000	RR40000	RR40000	B-150
RR55000	RR55000	RR55000	B-158
C Configurazioni e accessori in ingresso, installazione	<i>Input configurations and accessories, installation</i>	Konfigurationen und Zubehör am Eingang, Installation	
9 CONFIGURAZIONI INGRESSO	9 <i>INPUT CONFIGURATIONS</i>	9 EINGANGSKONFIGURATIO-NEN	C-3
10 ENTRATE VELOCI	10 <i>HIGH-SPEED INPUTS</i>	10 SCHNELLE EINGÄNGE	C-9
11 FRENI	11 <i>BRAKES</i>	11 BREMSEN	C-11
12 ACCOPPIAMENTI PER MOTORI IDRAULICI ED ELETTRICI	12 <i>HYDRAULIC AND ELECTRIC MOTORS COUPLINGS</i>	12 KUPPLUNGEN FÜR HYDRAULIK-MOTOREN UND ELEKTRO-MOTOREN	C-14
13 NORME PER L'INSTALLAZIONE	13 <i>INSTALLATION INSTRUCTIONS</i>	13 INSTALLATIONSVORSCHRIF-TEN	C-30



INDEX

INDICE

INDICE

A Informations générales

Información general

Informações gerais

1	SYMBOLES	1	SIMBOLOGÍA	1	SIMBOLOGIA	A-2
2	IDENTIFICATION DU PRODUIT	2	IDENTIFICACIÓN DEL PRODUCTO	2	IDENTIFICAÇÃO DO PRODUTO	A-4
3	CARACTERISTIQUES TECHNIQUES	3	CARACTERÍSTICAS TÉCNICAS	3	CARACTERÍSTICAS TÉCNICAS	A-8
4	SELECTION DES REDUCTEURS	4	SELECCIÓN DE LOS REDUCTORES	4	SELEÇÃO DOS REDUTORES	A-24
5	CONTROLES	5	COMPROBACIONES	5	VERIFICAÇÕES	A-30
6	LUBRIFICATION	6	LUBRICACIÓN	6	LUBRIFICAÇÃO	A-40
7	EMBALLAGE, MANUTENTION ET STOCKAGE	7	EMBALAJE, DESPLAZAMIENTO Y ALMACENAMIENTO	7	EMBALAGEM, MOVIMENTAÇÃO E ARMAZENAGEM	A-70

B Données techniques et dimensionnelles

Datos técnicos y dimensionales

Dados técnicos e dimensionais

8	COUPLES NOMINAUX	8	PARES NOMINALES	8	PARES NOMINAIS	B-3
	RR2500		RR2500		RR2500	B-4
	RR3200		RR3200		RR3200	B-20
	RR4000		RR4000		RR4000	B-36
	RR5200		RR5200		RR5200	B-52
	RR6500		RR6500		RR6500	B-68
	RR8000		RR8000		RR8000	B-84
	RR10000		RR10000		RR10000	B-100
	RR15000		RR15000		RR15000	B-116
	RR20000		RR20000		RR20000	B-126
	RR25000		RR25000		RR25000	B-134
	RR30000		RR30000		RR30000	B-142
	RR40000		RR40000		RR40000	B-150
	RR55000		RR55000		RR55000	B-158

C Configurations et accessoires à l'entrée, installation

Configuraciones y accesorios en entrada, instalación

Configurações e acessórios entrada, instalação

9	CONFIGURATIONS A L'ENTREE	9	CONFIGURACIONES EN ENTRADA	9	CONFIGURAÇÕES ENTRADA	C-3
10	ENTREES RAPIDES	10	ENTRADAS RÁPIDAS	10	ENTRADAS RÁPIDAS	C-9
11	FREINS	11	FRENOS	11	FREIOS	C-11
12	ACCOUPLLEMENTS POUR MOTEURS HYDRAULIQUES ET ELECTRIQUES	12	ACOPLAMIENTOS PARA MOTORES HIDRÁULICOS Y ELÉCTRICOS	12	ACOPLAGENS PARA MOTORES HIDRÁULICOS E ELÉTRICOS	C-14
13	NORMES POUR L'INSTALLATION	13	NORMAS PARA LA INSTALACIÓN	13	NORMAS PARA A INSTALAÇÃO	C-30

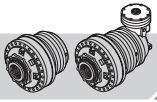

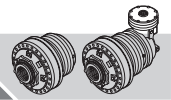

A

Informazioni generali
General information
Allgemeine Informationen
Informations générales
Información general
Informações gerais

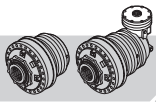

1 SIMBOLOGIA

1 SYMBOLS

1 VERWENDETE SYMBOLE

Simbolo Symbol Symbol	Unità di misura Unit of measure Maßeinheit	Descrizione	Description	Beschreibung
C_{rt}	-	Coefficiente di scambio termico	Energy exchange coefficient	Wärmeaustauschkoeffizient
$k_{r,1}, k_{r,2}$	-	Coefficienti correttivi del carico radiale in entrata/uscita	Corrective coefficients of the input/output radial load	Korrekturkoeffizient Querlast am Eingang/Ausgang
$f_{h,1}, f_{h,2}$	-	Fattore di durata in entrata/uscita	Input/output duration factor	Zeitfaktor Eingang/Ausgang
$F_{r,1}, F_{r,2}$	N	Carico radiale ammissibile sull'albero di entrata/uscita	Permitted radial load on the input/output shaft	Zulässige Querlast auf Eingangs-/Ausgangswelle
$F_{a,2}$	N	Carico assiale ammissibile sull'albero di uscita	Permitted axial load on the output shaft	Zulässige Achslast auf Ausgangswelle
f_s	-	Fattore di servizio	Service factor	Betriebsfaktor
η	-	Rendimento dinamico	Dynamic efficiency	Wirkungsgrad
h_r	h	Durata richiesta	Duration required	Verlangte Dauer
i	-	Rapporto di riduzione	Reduction ratio	Untersetungsverhältnis
i_r	-	Rapporto di riduzione richiesto	Reduction ratio required	Verlangtes Untersetungsverhältnis
K_t	-	Fattore di temperatura	Temperature factor	Temperaturfaktor
K_v	-	Fattore di velocità	Speed factor	Geschwindigkeitsfaktor
n_1	min ⁻¹	Velocità angolare in entrata	Angular input speed	Winkelgeschwindigkeit am Eingang
n_{1max}	min ⁻¹	Velocità angolare massima in entrata	Maximum angular input speed	Max. Winkelgeschwindigkeit am Eingang
n_2	min ⁻¹	Velocità angolare in uscita	Angular output speed	Winkelgeschwindigkeit am Ausgang
n_{2r}	min ⁻¹	Velocità angolare in uscita richiesta	Required angular output speed	Verlangte Winkelgeschwindigkeit am Ausgang
$n_{2r,eq}$	min ⁻¹	Velocità angolare in uscita equivalente	Equivalent angular output speed	Äquivalente Winkelgeschwindigkeit am Ausgang
P_1, P_2	kW	Potenza in entrata/uscita	Input/output power	Leistung am Eingang/Ausgang
P_t	kW	Potenza termica	Thermal power	Wärmeleistung
P'_t	kW	Potenza termica corretta	Corrected thermal power	Korrigierte Wärmeleistung
q	l/min	Portata d'olio nel circuito ausiliario di raffreddamento	Oil flow rate in the auxiliary cooling circuit	Öldurchsatz im Hilfskühlkreislauf
$t_1, t_2 \dots t_i$	-	Percentuale di durata dei livelli del ciclo di carico	Duration percentage of the loading cycle levels	Prozentuale Dauer der Stufen vom Lastzyklus
T_2	Nm	Coppia in uscita trasmissibile	Transmissible output torque	Übertragbares Drehmoment am Ausgang
T_{2c}	Nm	Coppia in uscita corretta	Corrected output torque	Korrigiertes Drehmoment am Ausgang
T_{2max}	Nm	Coppia in uscita massima	Maximum output torque	Max. Drehmoment am Ausgang
T_{2n}	Nm	Coppia in uscita nominale	Nominal output torque	Nennndrehmoment am Ausgang
T_{2r}	Nm	Coppia in uscita richiesta	Required output torque	Verlangtes Drehmoment am Ausgang
$T_{2r,eq}$	Nm	Coppia in uscita richiesta equivalente	Required equivalent output torque	Äquivalentes Drehmoment am Ausgang
T_F	Nm	Coppia frenante	Braking torque	Bremsdrehmoment
t_a	°C	Temperatura ambiente	Ambient temperature	Umgebungstemperatur
t_R	°C	Temperatura di funzionamento	Operating temperature	Betriebstemperatur
t_s	°C	Temperatura dell'olio in uscita dal circuito di raffreddamento	Temperature of the oil leaving the cooling circuit	Öltemperatur am Ausgang vom Kühlkreislauf

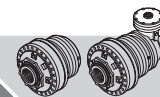

Symbole Símbolo Símbolo	Unité de mesure Unidad de medida Unidade de medida	Description	Descripción	Descrição
C_{rt}	-	Coefficient d'échange thermique	<i>Coefficiente de intercambio térmico</i>	Coeficiente de permutação térmica
$k_{r,1}, k_{r,2}$	-	Coefficients de correction de la charge radiale à l'entrée/sortie	<i>Coefficientes correctores de la carga radial en entrada/salida</i>	Coeficientes corretivos da carga radial em entrada/saída
$f_{h,1}, f_{h,2}$	-	Facteur de durée à l'entrée/sortie	<i>Factor de duración en entrada/salida</i>	Fator de duração em entrada/saída
$F_{r,1}, F_{r,2}$	N	Charge radiale admissible sur l'arbre d'entrée/de sortie	<i>Carga radial admitida sobre el eje de entrada/salida</i>	Carga radial admissível no eixo de entrada/saída
$F_{a,2}$	N	Charge axiale admissible sur l'arbre de sortie	<i>Carga axial admitida sobre el eje de salida</i>	Carga axial admissível no eixo de saída
f_s	-	Facteur de service	<i>Factor de servicio</i>	Fator de serviço
η	-	Rendement dynamique	<i>Rendimiento dinámico</i>	Rendimento dinâmico
h_r	h	Durée exigée	<i>Duración requerida</i>	Duração necessária
i	-	Rapport de réduction	<i>Relación de reducción</i>	Relação de redução
i_r	-	Rapport de réduction exigé	<i>Relación de reducción requerida</i>	Relação de redução necessária
K_t	-	Facteur de température	<i>Factor de temperatura</i>	Fator de temperatura
K_v	-	Facteur de vitesse	<i>Factor de velocidad</i>	Fator de velocidade
n_1	min ⁻¹	Vitesse angulaire à l'entrée	<i>Velocidad angular en entrada</i>	Velocidade angular em entrada
n_{1max}	min ⁻¹	Vitesse angulaire maximum à l'entrée	<i>Velocidad angular máxima en entrada</i>	Velocidade angular máxima em entrada
n_2	min ⁻¹	Vitesse angulaire à la sortie	<i>Velocidad angular en salida</i>	Velocidade angular em saída
n_{2r}	min ⁻¹	Vitesse angulaire à la sortie exigée	<i>Velocidad angular en salida requerida</i>	Velocidade angular em saída necessária
$n_{2r,eq}$	min ⁻¹	Vitesse angulaire à la sortie équivalente	<i>Velocidad angular en salida equivalente</i>	Velocidade angular em saída equivalente
P_1, P_2	kW	Puissance à l'entrée/sortie	<i>Potencia en entrada/salida</i>	Potência em entrada/saída
P_t	kW	Puissance thermique	<i>Potencia térmica</i>	Potência térmica
P'_t	kW	Puissance thermique corrigée	<i>Potencia térmica corregida</i>	Potência térmica corrigida
q	l/min	Débit d'huile dans le circuit auxiliaire de refroidissement	<i>Caudal de aceite en el circuito auxiliar de refrigeración</i>	Caudal do óleo no circuito auxiliar de arrefecimento
$t_1, t_2 \dots t_i$	-	Pourcentage de durée des niveaux du cycle de charge	<i>Porcentaje de duración de los niveles del ciclo de carga</i>	Porcentagem de duração dos níveis do ciclo de carga
T_2	Nm	Couple à la sortie transmissible	<i>Par en salida transmisible</i>	Par em saída transmissível
T_{2c}	Nm	Couple à la sortie corrigée	<i>Par en salida corregido</i>	Par em saída corrigido
T_{2max}	Nm	Couple à la sortie maximum	<i>Par en salida máximo</i>	Par em saída máximo
T_{2n}	Nm	Couple à la sortie nominal	<i>Par en salida nominal</i>	Par em saída nominal
T_{2r}	Nm	Couple à la sortie exigé	<i>Par en salida requerido</i>	Par em saída necessário
$T_{2r,eq}$	Nm	Couple à la sortie exigé équivalent	<i>Par en salida requerido equivalente</i>	Par em saída necessário equivalente
T_F	Nm	Couple freinant	<i>Par de frenado</i>	Par de freio
t_a	°C	Température ambiante	<i>Temperatura ambiente</i>	Temperatura ambiente
t_R	°C	Température de fonctionnement	<i>Temperatura de funcionamiento</i>	Temperatura de funcionamento
t_s	°C	Température de l'huile à la sortie du circuit de refroidissement	<i>Temperatura del aceite en salida del circuito de refrigeración</i>	Temperatura do óleo em saída do circuito de arrefecimento

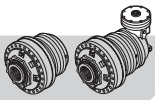

2 IDENTIFICAZIONE DEL PRODOTTO 2 PRODUCT IDENTIFICATION

2 PRODUKTKENNZEICHNUNG

2.1 Composizione di montaggio

2.1 Assembly layout

2.1 Montageaufbau

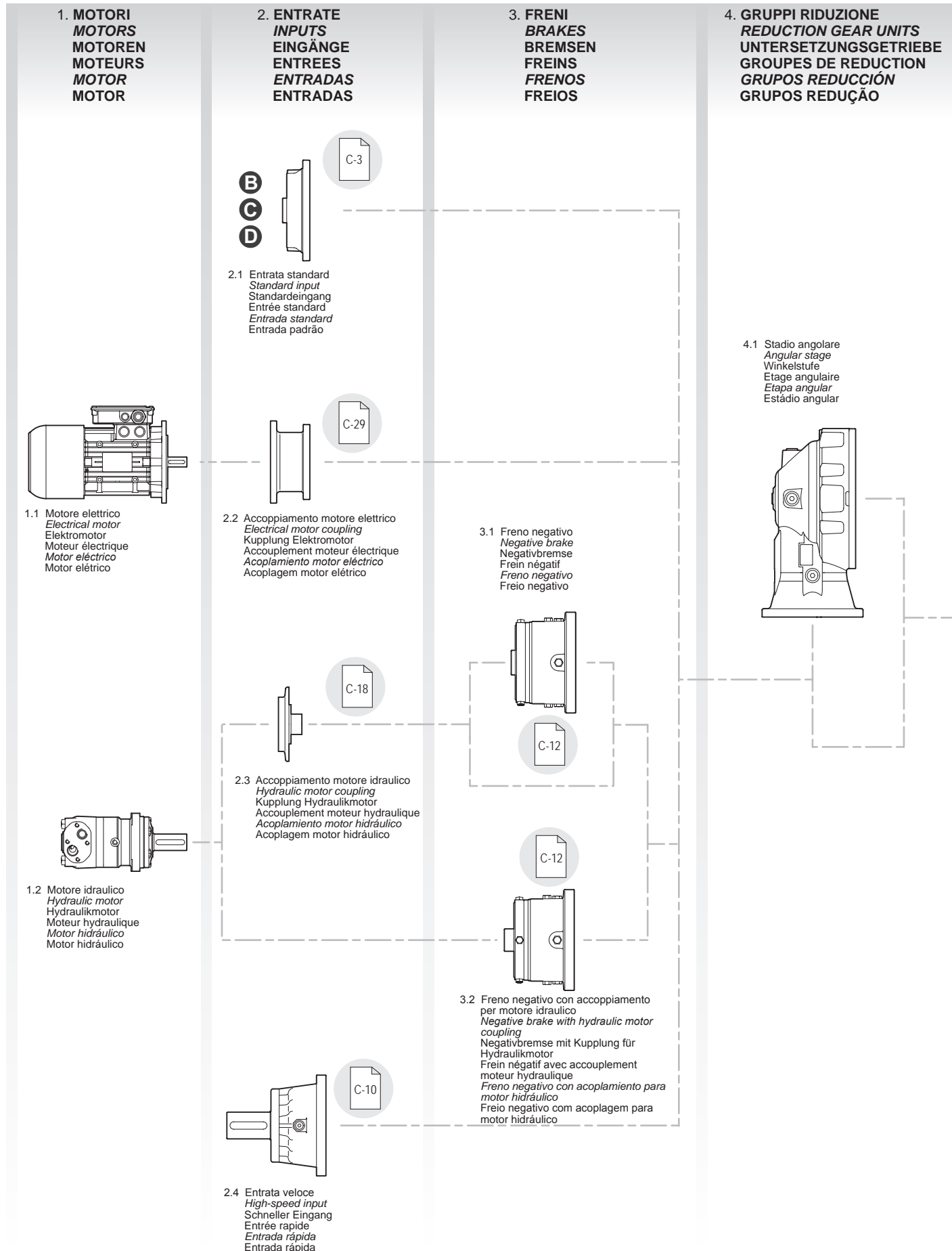

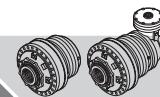

2 IDENTIFICATION DU PRODUIT

2 IDENTIFICACIÓN DEL PRODUCTO

2 IDENTIFICAÇÃO DO PRODUTO

2.1 Composition de montage

2.1 Composición de montaje

2.1 Composição de montagem

4. GRUPPI RIDUZIONE
REDUCTION GEAR UNITS
UNTERSETZUNGSGETRIEBE
GROUPES DE REDUCTION
GRUPOS REDUCCIÓN
GRUPOS REDUÇÃO

5. USCITE
OUTPUTS
AUSGÄNGE
SORTIES
SALIDAS
SAÍDAS

6. ACCESSORI USCITA
OUTPUT ACCESSORIES
ZUBEHÖR AUSGANG
ACCESSOIRES SORTIE
ACCESORIOS SALIDA
ACESSÓRIOS SAÍDA

4.2 Stadio planetario
Planetary stage
Planetenstufe
Etage planétaire
Etapa planetario
Estádio planetário

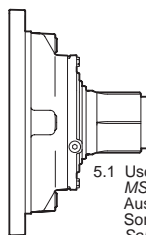
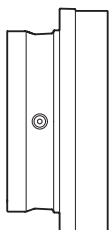

5.1 Uscita MS
MS Output
Ausgang MS
Sortie MS
Salida MS
Saída MS

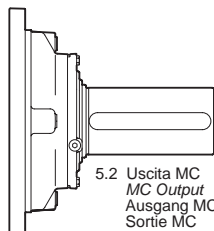

5.2 Uscita MC
MC Output
Ausgang MC
Sortie MC
Salida MC
Saída MC

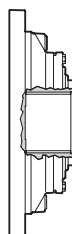

5.3 Uscita FS
FS Output
Ausgang FS
Sortie FS
Salida FS
Saída FS

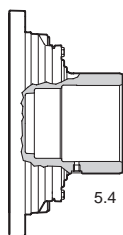

5.4 Uscita MH
MH Output
Ausgang MH
Sortie MH
Salida MH
Saída MH

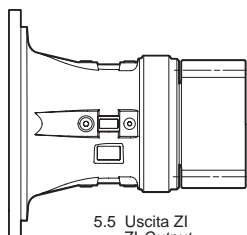

5.5 Uscita ZI
ZI Output
Ausgang ZI
Sortie ZI
Salida ZI
Saída ZI



6.1 Flangia presa moto-tipo 28
Drive intake flange – type 28
Antriebsflansch – Typ 28
Bride prise mouvement – type 28
Brida toma movimiento – tipo 28
Flange tomada movimento – tipo 28



6.3 Flangetta di fissaggio-tipo 12
End plate – type 12
Befestigungsflansch – Typ 12
Bride de fixation – type 12
Brida de sujeción – tipo 12
Pequena flange de fixação – tipo 12



6.2 Boccola scanalata-tipo 29
Splined bush – type 29
Nutbuchse – Typ 29
Douille cannelée – type 29
Buje acanalado – tipo 29
Disco com ranhuras – tipo 29



6.4 Albero scanalato-tipo 27
Splined shaft – type 27
Keilwelle – Typ 27
Arbre cannelé – type 27
Eje acanalado – tipo 27
Veio com ranhuras – tipo 27

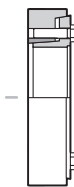

C-32

6.5 Calettatore per attrito
Friction shrink disc
Schrumpfscheibe
Frette de serrage par frottement
Engargolador por fricción
Encaixador por atrito

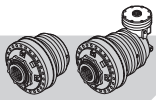

2.2 Designazione

I riduttori epicicloidali Reggiana Riduttori vengono identificati mediante una sigla composta nel seguente modo:

2.2 Designation

The Reggiana Riduttori planetary reduction gears are identified by an acronym made up in the following way:

2.2 Bezeichnung

Die Planetengetriebe von Reggiana Riduttori sind durch einen Code gekennzeichnet, der folgende Bedeutung hat:

RR	2500	L3	FS	53.35	RF
					Configurazione ingresso (opzionale) / Input configuration (optional) Konfiguration am Eingang (optional) - Ingresso standard / Standard input / Standardeingang RF Predisposizione RF / Setup RF / Auslegung RF BOC Predisposizione BOC / Setup BOC / Auslegung BOC
					Rapporto di riduzione / Reduction ratio / Untersetzungsverhältnis i = 4 - 2500
					Tipo di uscita / Type of output / Typ Ausgang MS Maschio scanalato / Male splined / Zum Einstecken mit Nut MC Maschio cilindrico / Male cylindrical / Zum Einstecken zylindrisch FS Femmina scanalato / Female splined / Zum Aufstecken mit Nut MH Maschio cavo / Male hollow / Zum Einstecken hohl ZI Pignone integrale / Integral pinion / Integriertem ritzel
					Esecuzione e numero stadi / Version and number of stages / Ausführung und Anzahl Stufen L1 Singolo stadio lineare / Single linear stage / Einstufig linear L2 Doppio stadio lineare / Double linear stage / Zweistufig linear L3 Triplo stadio lineare / Triple linear stage / Dreistufig linear L4 Quadruplo stadio lineare / Quadruple linear stage / Viestufig linear A2 Doppio stadio angolare / Double angular stage / Zweistufig abgewinkelt A3 Triplo stadio angolare / Triple angular stage / Dreistufig abgewinkelt A4 Quadruplo stadio angolare / Quadruple angular stage / Vierstufig abgewinkelt
					Grandezza / Size / Größe 2500, 3200, 4000, 5200, 6500, 8000, 10000, 15000, 20000, 25000, 30000, 40000, 55000
Prefisso invariabile / Unvarying prefix / Vorgegebene Vorziffer					

RR

Nel caso sia possibile montare più di una grandezza di coppia conica in ingresso, le diverse alternative per le combinazioni risultanti si indicano con (A), (B) e (C), a partire dall'alternativa con coppia conica più piccola.
Esempio: RR2500 A2(A), RR2500 A2(B), RR2500 A2(C).

*If it is possible to mount more than one bevel gear size in input, the different alternatives for the combinations are indicated with (A), (B) and (C) starting from the alternative with the smallest bevel gear.
Example: RR2500 A2(A), RR2500 A2(B), RR2500 A2(C).*

Falls mehrere Kegelpaargrößen am Eingang montiert werden können, werden die alternativen Kombinationen mit (A), (B) und (C) angegeben, ausgehend vom kleinsten Kegelpaar.
Beispiel: RR2500 A2(A), RR2500 A2(B), RR2500 A2(C).

2.3 Marcatura del prodotto e designazione del tipo

Tutti i prodotti Reggiana Riduttori sono dotati di targhetta di identificazione, posizionata in modo da risultare facilmente leggibile, anche dopo l'installazione.

La seguente figura mostra un esempio di targhetta.

2.3 Product marking and type designation

All Reggiana Riduttori products have a id plate positioned so as to be easily readable also after installation.

The following figure shows an example of a plate.

2.3 Produktkennzeichnung und Typschild

Alle Produkte von Reggiana Riduttori weisen ein Typenschild auf, das so angebracht ist, dass es auch nach der Installation leicht abgelesen werden kann.

Die Abbildung unten zeigt ein Beispiel.

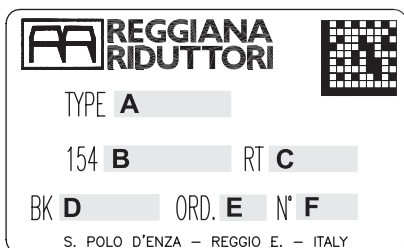

	Legenda	Legend	Legende
A	Tipo di riduttore (sigla)	Reduction gear type (code)	Untersetzungstyp (Abzeichnung)
B	Codice identificativo di ordinazione	ID code for ordering	Identifizierungscode der Bestellung
C	Rapporto di riduzione	Reduction ratio	Untersetzungsverhältnis
D	Coppia frenante	Braking torque	Bremsmoment
E	N° di ordine	Order Number	Auftragsnummer
F	N° progressivo di matricola e anno di produzione	Progressive serial number and year of production	Fortlaufende Seriennummer und Baujahr

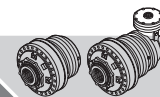

2.2 Designation

Les réducteurs épicycloïdaux Reggiana Riduttori sont identifiés au moyen d'un sigle composé de la manière suivante:

2.2 Denominación

Los reductores epicicloidales Reggiana Riduttori están identificados por una sigla formada como sigue:

2.2 Designação

Os redutores epicicloidais Reggiana Riduttori são identificados mediante uma referência composta no seguinte modo:

RR	2500	L3	FS	53.35	RF
<p>Configuration a l'entrée (en option) / Configuración en entrada (opcional) / Configuração em entrada (opcional)</p> <p>- Entrée standard / Entrada estándar / Entrada padrão</p> <p>RF Préréglage RF / Predisposición RF / Predisposição RF</p> <p>BOC Préréglage BOC / Predisposición BOC / Predisposição BOC</p>					
<p>Rapport de réduction / Relación de reducción / Relação de redução</p> <p>i = 4 - 2500</p>					
<p>Type de sortie / Tipo de salida / Tipo de saída</p> <p>MS Mâle cannelé / Macho acanalado / Macho com ranhuras</p> <p>MC Mâle cylindrique / Macho cilíndrico / Macho cilíndrico</p> <p>FS Femelle cannelée / Hembra acanalada / Fêmea com ranhuras</p> <p>MH Mâle creux / Macho hueco / Macho ôco</p> <p>ZI Pignon integral / Piñon integral / Pinhão integrado</p>					
<p>Execution et nombre d'étages / Realización y n. etapas / Execução e número de estádios</p> <p>L1 Simple étage linéaire / Etapa lineal individual / Um estádio linear</p> <p>L2 Double étage linéaire / Doble etapa lineal / Duplo estádio linear</p> <p>L3 Triple étage linéaire / Triple etapa lineal / Triplo estádio linear</p> <p>L4 Quadruple étage linéaire / Cuádruple etapa lineal / Quadruplo estádio linear</p> <p>A2 Double étage angulaire / Doble etapa angular / Duplo estádio angular</p> <p>A3 Triple étage angulaire / Triple etapa angular / Triplo estádio angular</p> <p>A4 Quadruple étage angulaire / Cuádruple etapa angular / Quadruplo estádio angular</p>					
<p>Grandeur / Talla / Grandeza</p> <p>2500, 3200, 4000, 5200, 6500, 8000, 10000, 15000, 20000, 25000, 30000, 40000, 55000</p>					
<p>Prefixe invariable / Prefijo invariable / Prefixo invariável</p> <p>RR</p>					

S'il est possible de monter plus d'une grandeur de couple conique à l'entrée, les différentes alternatives pour les combinaisons possibles sont indiquées par les lettres (A), (B) et (C), à partir de l'alternative avec un couple conique plus petit.

Exemple: RR2500 A2(A), RR2500 A2(B), RR2500 A2(C).

Si fuese posible montar más de una talla de par cónico en entrada, las diferentes alternativas para las combinaciones resultante se indican con (A), (B) y (C), a partir de la alternativa con par cónico más pequeño.

Ejemplo: RR2500 A2(A), RR2500 A2(B), RR2500 A2(C).

No caso em que seja possível montar mais do que uma grandeza de par cónico em entrada, as várias alternativas para as combinações que resultam são indicadas com (A), (B) e (C), a partir da alternativa com par cónico mais pequeno.

Exemplo: RR2500 A2(A), RR2500 A2(B), RR2500 A2(C).

2.3 Marquage du produit et désignation du type

Sur tous les produits Reggiana Riduttori, une plaquette d'identification est appliquée. Elle est positionnée de manière à être facile à lire, même une fois le réducteur installé.

La figure suivante montre un exemple de la plaquette.



2.3 Marcado del producto y denominación del tipo

Todos los productos Reggiana Riduttori llevan una placa de identificación, colocada de manera que resulte fácilmente legible, también después de la instalación.

La siguiente figura presenta un ejemplo de placa.

2.3 Marcação do produto e designação do tipo

Todos os produtos Reggiana Riduttori são munidos de placa de identificação, colocada de modo a ser lida com facilidade, também depois da instalação.

A seguinte figura ilustra um exemplo de placa.

	Légende	Leyenda	Legenda
A	Type de réducteur (sigle)	Tipo de reductor (sigla)	Tipo de redutor (referência)
B	Code d'identification de la commande	Código identificador de pedido	Código identificativo de encomenda
C	Rapport de réduction	Relación de reducción	Relação de redução
D	Couple freinant	Par frenador	Par de freio
E	N° de commande	N° de pedido	N° de ordem
F	N° progressif de série et année de fabrication	N° progresivo de matrícula y año de producción	N° progressivo de matrícula e ano de produção

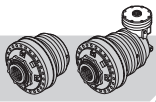

3 CARATTERISTICHE TECNICHE

3.1 Funzioni generali, gamma di applicazioni e utilizzo previsto

I riduttori epicicloidali Reggiana Riduttori sono progettati per realizzare la trasmissione di potenza all'interno di macchine operatrici. Essi possono essere collegati direttamente o indirettamente ad un motore di tipo elettrico o idraulico.

I riduttori epicicloidali vengono utilizzati nell'ambito di diverse applicazioni, sia industriali che mobili, tra le quali: industria meccanica, industria chimica e plastica, industria alimentare, edilizia e costruzioni, industria estrattiva, agricoltura e foreste, trasporti e sollevamento, settore marino, generatori eolici di energia.

3 TECHNICAL CHARACTERISTICS

3.1 General functions, range of applications and intended use

The Reggiana Riduttori planetary reduction gears are designed for transmitting power inside operating machines. They can be connected directly or indirectly to either an electric or hydraulic motor.

The planetary reduction gears are used for many different types of application, both industrial and mobile some of which are: the mechanical industry, the chemical and plastics industry, the food industry, building and constructions, mining industry, agriculture and forestry, transporting and lifting, marine sector, wind generators of energy.

3 TECHNISCHE BESCHREIBUNG

3.1 Allgemeine Funktionen, Anwendungsbereiche und vorgesehene Anwendung

Die Planetengetriebe von Reggiana Riduttori werden für die Leistungsübertragung im Inneren von Arbeitsmaschinen konzipiert und gefertigt. Sie können direkt oder indirekt an einen Elektromotor oder einen Hydraulikmotor angeschlossen werden.

Die Planetengetriebe werden sowohl in der Industrie, als auch im Fahrzeugbau in verschiedenen Anwendungen eingesetzt, darunter: Maschinenbau, chemische und Kunststoff verarbeitende Industrie, Lebensmittelindustrie, Bauwirtschaft, Bergbau, Land- und Forstwirtschaft, Transport- und Hubtechnik, Schiffbau, Windkraftanlagen.



Utilizzare il riduttore soltanto per gli usi previsti in fase di progetto. L'impiego per usi impropri può essere causa di pericolo per la sicurezza e la salute delle persone. Gli usi previsti sono quelli industriali e mobili per i quali sono stati sviluppati e costruiti i riduttori.

Use the reduction gear only for the uses contemplated in the project phase. Using it improperly can be the cause of danger for the safety and health of people.

The reductions gears have been designed and made for industrial and mobile uses.

Die Planetengetriebe dürfen nur für den vom Hersteller vorgesehenen Zweck verwendet werden. Bei unsachgemäßem Gebrauch kann die Sicherheit und Gesundheit von Personen gefährdet werden. Unter vorgesehenem Gebrauch werden die industriellen und mobilen Anwendungen verstanden, für die die Planetengetriebe entwickelt und gebaut worden sind.

3.2 Coppia in uscita nominale

T_{2n} [Nm]

È un valore di coppia caratteristico di ciascuna grandezza di riduttore, utile per una selezione di massima della grandezza del riduttore. Fare riferimento alla tabella presente all'inizio della sezione relativa ai dati tecnici.

3.2 Nominal output torque

T_{2n} [Nm]

It is a torque value characteristic of each reduction gear size, useful for a general selection of the size of the reduction gear. Please refer to the table at the beginning of the technical data section.

3.2 Nominales Ausgangsdrehmoment

T_{2n} [Nm]

Dabei handelt es sich um das charakteristische Drehmoment jeder Untersetzungsgröße, das bei der Auswahl der Größe des Planetengetriebes hilfreich ist. Bitte die Tabelle am Anfang der technischen Daten beachten.

3.3 Coppia in uscita

T_2 [Nm]

È il valore di coppia trasmissibile, in funzionamento continuo e uniforme con fattore di servizio $f_s=1$, per un dato valore del fattore di durata f_h . I valori di T_2 , calcolati per alcuni valori del fattore di durata f_h , sono riportati nella tabella dei dati tecnici posta all'inizio della sezione relativa ad ogni grandezza di riduttore.

La coppia T_2 è limitata dalla resistenza a flessione o dalla resistenza superficiale dei denti degli ingranaggi, in accordo con la norma ISO 6336, ovvero dalla resistenza dei cuscinetti, in accordo con la norma ISO 281.

3.3 Output torque

T_2 [Nm]

It is the transmissible torque value in continuous and uniform operation with a service factor $f_s=1$ for a given value of the duration factor f_h . The T_2 values, calculated for some values of the duration factor f_h , are given in the technical data table at the beginning of the section relative to each reduction gear size.

T_2 torque is limited to the bending strength or the surface strength of the gear teeth, in agreement with the ISO 6336 standard, or bearing strength, in agreement with the ISO 281 standard.

3.3 Ausgangsdrehmoment

T_2 [Nm]

Dabei handelt es sich um den Wert vom übertragbaren Drehmoment bei gleichmäßigem Dauerbetrieb mit Betriebsfaktor $f_s=1$ für einen gegebenen Wert vom Zeitfaktor f_h . Die Werte von T_2 , die für einige Werte vom Zeitfaktor f_h berechnet worden sind, sind in der Tabelle mit den technischen Daten am Anfang vom Abschnitt der jeweiligen Untersetzungsgröße angegeben. Das Drehmoment T_2 wird von der Biegefestigkeit oder dem Oberflächenwiderstand der Zähne vom Getriebe nach Vorgabe der Norm ISO 6336 beschränkt, oder von der Widerstandsfähigkeit der Lager nach Vorgabe der Norm ISO 281.

3.4 Coppia in uscita massima

T_{2max} [Nm]

Rappresenta il valore di coppia massima applicabile in uscita al riduttore per brevi durate o per picchi occasionali, senza il verificarsi di danneggiamenti permanenti agli elementi più sollecitati.

3.4 Maximum output torque

T_{2max} [Nm]

It is the maximum torque value applicable in reduction gear output for short lengths of time or for occasional peaks, without any permanent damage to the most stressed elements.

3.4 Maximales Ausgangsdrehmoment

T_{2max} [Nm]

Dabei handelt es sich um den Wert vom Drehmoment, das maximal am Ausgang des Planetengetriebes für kurze Zeit oder gelegentliche Spitzen angelegt werden kann, ohne dass dies zu einer dauerhaften Schädigung der am stärksten Belasteten Bauteile führt.

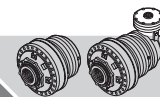

3 CARACTERISTIQUES TECHNIQUES

3.1 Fonctions générales, gamme d'applications et utilisation prévue

Les réducteurs épicycloïdaux Reggiana Riduttori sont projetés pour réaliser la transmission de puissance dans des engins de travaux publics. Ils peuvent être raccordés directement ou indirectement à un moteur de type électrique ou hydraulique. Les réducteurs épicycloïdaux sont utilisés dans le cadre de plusieurs applications, aussi bien dans le domaine industriel que mobile, parmi lesquelles: l'industrie mécanique, l'industrie chimique et plastique, l'industrie alimentaire, le bâtiment et les constructions, l'industrie extractive, l'agriculture et la sylviculture, le transport et les systèmes de levage, la marine, les générateurs éoliens.



N'utiliser le réducteur que pour les usages pour lesquels il a été projeté. Son utilisation impropre peut être cause de danger pour la sécurité et la santé des personnes.

Les usages prévus sont les emplois industriels et mobiles pour lesquels les réducteurs ont été élaborés et fabriqués.

3.2 Couple à la sortie nominal

T_{2n} [Nm]

Il s'agit d'une valeur de couple caractéristique de chaque grandeur de réducteur, utile à une sélection de principe de la grandeur du réducteur. Se rapporter au tableau se trouvant au début de la section relative aux caractéristiques techniques.

3.3 Couple à la sortie

T_2 [Nm]

Il s'agit de la valeur de couple transmissible, en service continu et uniforme avec facteur de service $f_s=1$, pour une valeur du facteur de durée donnée f_h . Les valeurs de T_2 , calculées pour certaines valeurs du facteur de durée f_h , sont indiquées sur le tableau des caractéristiques techniques se trouvant au début de la section relative à chaque grandeur de réducteur.

Le couple T_2 est limité par la résistance à la flexion et par la résistance superficielle des dents des engrenages, conformément à la norme ISO 6336, c'est-à-dire par la résistance des roulements, conformément à la norme ISO 281.

3.4 Couple à la sortie maximum

T_{2max} [Nm]

Il représente la valeur de couple maximum applicable à la sortie au réducteur pour de courtes durées ou pour des pics occasionnels, sans provoquer de dommages permanents aux éléments les plus sollicités.

3 CARACTERÍSTICAS TÉCNICAS

3.1 Funciones generales, gama de aplicaciones y uso previsto

Los reductores epicicloïdales Reggiana Riduttori están proyectados para realizar la transmisión de potencia dentro de máquinas operadoras. Se pueden acoplar directamente o indirectamente con un motor de tipo eléctrico o hidráulico.

Los reductores epicicloïdales se utilizan en el ámbito de distintas aplicaciones, tanto industriales como móviles, entre las cuales: industria mecánica, industria química y del plástico, industria alimentaria, de la construcción, industria minera, agricultura y forestal, transportes y elevación, sector marítimo, generadores eólicos de energía.

Utilizar el reductor sólo para los usos previstos en la fase de proyecto. La utilización para usos no adecuados puede causar peligros para la seguridad y la salud de las personas.

Los usos previstos son aquellos industriales y móviles para los cuales han sido desarrollados y construidos los reductores.

3.2 Par en salida nominal

T_{2n} [Nm]

Es un valor de par característico de cada talla de reductor, útil para una selección aproximada de la talla del reductor. Hágase referencia a la tabla presentada al inicio de la sección referente a los datos técnicos.

3.3 Par en salida

T_2 [Nm]

Es el valor de par transmisible, en funcionamiento continuo y uniforme con factor de servicio $f_s=1$, para un dado valor del factor de duración f_h . Los valores de T_2 , calculados para algunos valores del factor de duración f_h , se indican en la tabla de los datos técnicos presentada al inicio de la sección referente a cada talla de reductor.

El par T_2 está limitado por la resistencia a la flexión o por la resistencia superficial de los dientes de los engranajes, según la norma ISO 6336, o bien por la resistencia de los cojinetes, según la norma ISO 281.

3.4 Par en salida máximo

T_{2max} [Nm]

Representa el valor de par máximo aplicable en salida al reductor por breves duraciones o por picos ocasionales, sin que se produzcan daños permanentes a los elementos mayormente bajo esfuerzo.

3 CARACTERÍSTICAS TÉCNICAS

3.1 Funções gerais, gama de aplicações e emprego previsto

Os redutores epicicloïdales Reggiana Riduttori foram concebidos para realizar a transmissão de potência no interior de máquinas operadoras. Os mesmos podem ser ligados direta ou indiretamente a um motor de tipo elétrico ou hidráulico.

Os redutores epicicloïdales são empregues no âmbito de várias aplicações, quer industriais quer móveis, entre as quais: indústria mecânica, indústria química e dos plásticos, indústria alimentar, construção civil, indústria minerária, agricultura e florestas, transportes e levantamento, setor marítimo, geradores eólicos de energia.

Usar o reductor exclusivamente para os usos previstos na fase de projeto. O emprego em usos impróprios pode ser causa de perigo para a segurança e a saúde das pessoas.

Os usos previstos são aqueles industriais e móveis para os quais os redutores foram concebidos e construídos.

3.2 Par em saída nominal

T_{2n} [Nm]

É um valor de par característico de cada uma das grandezas do reductor, útil para uma seleção aproximada da grandeza do reductor. Consultar a tabela presente no início da seção relativa aos dados técnicos.

3.3 Par em saída

T_2 [Nm]

É o valor de par transmissível, em funcionamento contínuo e uniforme com fator de serviço $f_s=1$, para um determinado valor do fator de duração f_h . Os valores de T_2 , calculados para alguns valores do fator de duração f_h , estão indicados na tabela dos dados técnicos que se encontra no início da seção relativa a cada grandeza do reductor.

O par T_2 é limitado pela resistência à flexão ou pela resistência superficial dos dentes das engrenagens, de acordo com a norma ISO 6336, ou pela resistência dos rolamentos, de acordo com a norma ISO 281.

3.4 Par em saída máximo

T_{2max} [Nm]

Representa o valor de par máximo aplicável em saída ao reductor por breves períodos ou por picos ocasionais, sem que se verifiquem danos permanentes nos elementos mais solicitados.

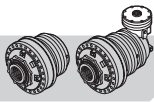

Nel caso di supporto uscita MS o MC, la coppia massima applicabile può essere limitata dalla eventuale presenza di un carico radiale.

In the case of the MS or MC output support, the maximum applicable torque can be limited by a radial load if present.

Bei Ausgangslager MS oder MC kann das maximal anlegbare Drehmoment durch das eventuelle Vorhandensein einer Querlast eingeschränkt werden.

3.5 Coppia in uscita richiesta

T_{2r} [Nm]

È il valore di coppia in uscita che si intende applicare al riduttore, in base ai dati di funzionamento dell'applicazione.

3.5 Required output torque

T_{2r} [Nm]

It is the value of output torque one intends applying to the reduction gear based on the operating data of the application.

3.5 Verlangtes Ausgangsdrehmoment

T_{2r} [Nm]

Dabei handelt es sich um den Wert vom Ausgangsdrehmoment, das an das Planetengetriebe angelegt werden soll. Der Wert basiert auf den Funktionsdaten der Anwendung.

3.6 Coppia in uscita corretta

T_{2c} [Nm]

Si calcola in base alla coppia richiesta e al fattore di servizio ed è il valore in base al quale si seleziona il riduttore idoneo per una data applicazione.

3.6 Corrected output torque

T_{2c} [Nm]

It is calculated on the basis of the torque required and on the service factor and is the value on the basis of which the reduction gear is chosen suitable for a given application.

3.6 Korrigiertes Ausgangsdrehmoment

T_{2c} [Nm]

Dieser Wert wird aus dem verlangten Ausgangsdrehmoment und dem Betriebsfaktor errechnet und stellt den Ausgangswert für die Auswahl der Untersetzung dar, die sich für die jeweilige Anwendung eignet.

3.7 Velocità in entrata

n_1 [min^{-1}]

È la velocità del motore collegato in ingresso al riduttore o, nel caso di collegamento indiretto, dell'albero di entrata del riduttore.

3.7 Input speed

n_1 [min^{-1}]

It is the speed of the motor connected to the reduction gear input or, in the case of an indirect connection, of the reduction gear's input shaft.

3.7 Eingangsgeschwindigkeit

n_1 [min^{-1}]

Dabei handelt es sich um die Geschwindigkeit vom Motor, der am Eingang vom Planetengetriebe angeschlossen ist, oder, bei indirektem Anschluss, von der Eingangswelle des Planetengetriebes.

3.8 Velocità in uscita

n_2 [min^{-1}]

È la velocità dell'albero di uscita del riduttore, funzione della velocità in entrata n_1 e del rapporto di riduzione effettivo i .

3.8 Output speed

n_2 [min^{-1}]

It is the speed of the reduction gear's output shaft, as a function of the input speed n_1 and of the actual reduction ratio i .

3.8 Ausgangsgeschwindigkeit

n_2 [min^{-1}]

Dabei handelt es sich um die Geschwindigkeit der Ausgangswelle vom Planetengetriebe, die sich aus der Eingangsgeschwindigkeit n_1 und dem effektiven Untersetzungsverhältnis i ergibt.

3.9 Rapporto di riduzione

i

Indica l'effettivo rapporto tra la velocità in entrata n_1 e la velocità in uscita n_2 del riduttore:

3.9 Reduction ratio

i

It indicates the actual ratio between the reduction gear's input speed n_1 and output speed n_2 :

3.9 Untersetzungsverhältnis

i

Dabei handelt es sich um das effektive Verhältnis von Eingangsgeschwindigkeit n_1 zu Ausgangsgeschwindigkeit n_2 vom Planetengetriebe:

$$i = \frac{n_1}{n_2}$$

I rapporti di riduzione disponibili sono riportati nella tabella dei dati tecnici per ogni grandezza di riduttore. Su richiesta è possibile ottenere ulteriori rapporti di riduzione.

The reduction ratios available are given in the technical data table for each reduction gear size. Other reduction ratios can be obtained on request.

Die verfügbaren Untersetzungsverhältnisse sind für jede Größe vom Planetengetriebe in der Tabelle mit den technischen Daten zusammengestellt. Auf Wunsch sind weitere Untersetzungsverhältnisse erhältlich.

3.10 Velocità in entrata massima

$n_{1\text{max}}$ [min^{-1}]

Indica la velocità massima ammessa in entrata per brevi durate o in funzionamento intermittente; la velocità in entrata del riduttore è limitata dalla velocità periferica degli ingranaggi, dai cuscinetti e dalle tenute.

3.10 Maximum input speed

$n_{1\text{max}}$ [min^{-1}]

It indicates the maximum permitted input speed for short lengths of time or intermittently; the reduction gear's input speed is limited by the peripheral speed of the gears, by the bearings and by the seals.

3.10 Maximale Eingangsgeschwindigkeit

$n_{1\text{max}}$ [min^{-1}]

Dabei handelt es sich um die maximal zulässige Eingangsgeschwindigkeit für kurze Dauer oder bei unterbrochenem Betrieb. Die Eingangsgeschwindigkeit vom Planetengetriebe ist durch die Peripheriegeschwindigkeit von Zahnrädern, Lagern und Dichtungen beschränkt.

3.11 Senso di rotazione

3.11 Rotation direction

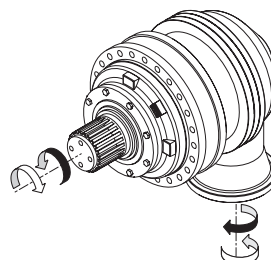
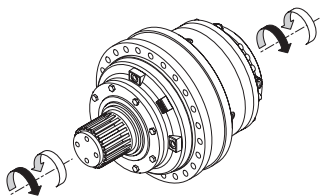

3.11 Rotationsrichtung

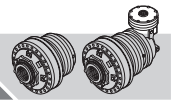

Dans le cas du support de sortie MS ou MC, le couple maximum applicable peut être limité par la présence éventuelle d'une charge radiale.

En caso de soporte de salida MS ó MC, el par máximo aplicable puede estar limitado por la eventual presencia de una carga radial.

No caso de suporte saída MS ou MC, o par máximo aplicável pode ser limitado pela eventual presença de uma carga radial.

3.5 Couple à la sortie exigé

T_{2r} [Nm]

Il s'agit de la valeur de couple à la sortie qu'on veut appliquer au réducteur, sur la base des caractéristiques d'opération de l'application.

3.5 Par en salida requerido

T_{2r} [Nm]

Es el valor de par en salida que se desea aplicar al reductor, sobre la base de los datos de funcionamiento de la aplicación.

3.5 Par em saída necessário

T_{2r} [Nm]

É o valor de par em saída que se deseja aplicar ao redutor, segundo os dados de funcionamento da aplicação.

3.6 Couple à la sortie corrigé

T_{2c} [Nm]

Il est calculé sur la base du couple exigé et du facteur de service et c'est la valeur en fonction de laquelle on choisit le réducteur le plus approprié à une application donnée.

3.6 Par en salida corregido

T_{2c} [Nm]

Se calcula sobre la base del par requerido y del factor de servicio y es el valor sobre la base del cual se selecciona el reductor idóneo para una determinada aplicación.

3.6 Par em saída corrigido

T_{2c} [Nm]

É calculado segundo o par necessário e o fator de serviço, sendo o valor segundo o qual se selecciona o redutor idóneo para uma determinada aplicação.

3.7 Vitesse à l'entrée

n_1 [min^{-1}]

Il s'agit de la vitesse du moteur relié à l'entrée au réducteur ou, dans le cas de connexion indirecte, de l'arbre d'entrée du réducteur.

3.7 Velocidad en entrada

n_1 [min^{-1}]

Es la velocidad del motor conectado a la entrada del reductor o, en el caso de conexión indirecta, del eje de entrada del reductor.

3.7 Velocidade em entrada

n_1 [min^{-1}]

É a velocidade do motor ligado à entrada do redutor ou, no caso de ligação indireta, do veio de entrada do redutor.

3.8 Vitesse à la sortie

n_2 [min^{-1}]

Il s'agit de la vitesse de l'arbre de sortie du réducteur, en fonction de la vitesse à l'entrée n_1 et du rapport de réduction effectif i .

3.8 Velocidad en salida

n_2 [min^{-1}]

Es la velocidad del eje de salida del reductor, función de la velocidad en entrada n_1 y de la relación de reducción efectiva i .

3.8 Velocidade em saída

n_2 [min^{-1}]

É a velocidade do veio de saída do redutor, função da velocidade em entrada n_1 e da relação de redução efetiva i .

3.9 Rapport de réduction

i

Il indique le rapport effectif entre la vitesse à l'entrée n_1 et la vitesse à la sortie n_2 du réducteur:

3.9 Relación de reducción

i

Indica la efectiva relación entre la velocidad en entrada n_1 y la velocidad en salida n_2 del reductor:

3.9 Relação de redução

i

Indica a efetiva relação entre a velocidade em entrada n_1 e a velocidade em saída n_2 do redutor:

$$i = \frac{n_1}{n_2}$$

Les rapports de réduction existants sont indiqués dans le tableau des caractéristiques techniques pour chaque grandeur de réducteur. Sur demande, il est possible d'obtenir des rapports de réduction supplémentaires.

Las relaciones de reducción disponibles se indican en la tabla de los datos técnicos para cada talla de reductor. Bajo demanda es posible obtener ulteriores relaciones de reducción.

As relações de redução disponíveis estão indicadas na tabela dos dados técnicos para cada grandeza de redutor. A pedido, é possível obter outras relações de redução.

3.10 Vitesse à l'entrée maximum

$n_{1\text{max}}$ [min^{-1}]

Elle indique la vitesse maximum admise à l'entrée pour de courtes durées ou en fonctionnement intermittent; la vitesse à l'entrée du réducteur est limitée par la vitesse périphérique des engrenages, par les roulements et les garnitures.

3.10 Velocidad en entrada máxima

$n_{1\text{max}}$ [min^{-1}]

Indica la velocidad máxima admitida en entrada por breves duraciones o en funcionamiento intermitente; la velocidad en entrada del reductor está limitada por la velocidad periférica de los engranajes, por los cojinetes y por las estanqueidades.

3.10 Velocidade em entrada máxima

$n_{1\text{max}}$ [min^{-1}]

Indica a velocidade máxima admitida em entrada por breves períodos ou em funcionamento intermitente; a velocidade em entrada do redutor é limitada pela velocidade periférica das engrenagens, pelos rolamentos e pelas vedações.

3.11 Sens de rotation

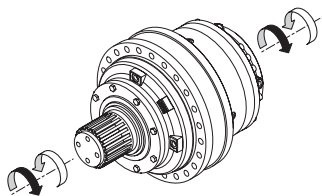

3.11 Sentido de giro

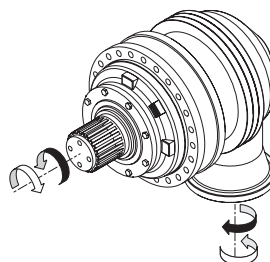

3.11 Direcção de rotação

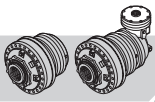
**3.12 Fattore di durata in entrata/uscita** $f_{h,1}, f_{h,2}$

È il prodotto della velocità in entrata/uscita per la durata richiesta:

3.12 Input/output duration factor $f_{h,1}, f_{h,2}$

It is the product of the input/output speed for the duration required:

3.12 Zeitfaktor Eingang/Ausgang $f_{h,1}, f_{h,2}$

Dabei handelt es sich um das Produkt aus der Eingang-/Ausgangsgeschwindigkeit und der verlangten Zeitdauer:

$$f_{h,1} = n_1 \cdot h_r$$

$$f_{h,2} = n_2 \cdot h_r$$

3.13 Potenza in entrata P_1 [kW]

È la potenza applicata in ingresso al riduttore, mediante collegamento diretto o indiretto (con ulteriori organi di trasmissione) di un motore.

3.13 Input power P_1 [kW]

It is the power applied in input to the reduction gear by either a direct or indirect connection (with additional transmission parts) of a motor.

3.13 Eingangsleistung P_1 [kW]

Dabei handelt es sich um die Leistung, die am Eingang vom Planetengetriebe über einen direkt oder indirekt (mit weiteren Übertragungsorganen) angeschlossenen Motor anliegt.

3.14 Potenza in uscita P_2 [kW]

È la potenza richiesta dall'utilizzatore collegato in uscita al riduttore. Si può calcolare come:

3.14 Output power P_2 [kW]

It is the power required by the user connected in output to the reduction gear. It can be calculated as:

3.14 Ausgangsleistung P_2 [kW]

Dabei handelt es sich um die vom Abnehmer verlangte Leistung, der am Ausgang vom Planetengetriebe angeschlossen ist. Die Ausgangsleistung wird wie folgt berechnet:

$$P_2 = \frac{T_{2r} \cdot n_2}{9550}$$

3.15 Rendimento η

È un coefficiente adimensionale dato dal rapporto tra la potenza in uscita P_2 e quella in entrata P_1 :

3.15 Efficiency η

It is a dimensionless coefficient given by the ratio between the output power P_2 and input power P_1 :

3.15 Wirkungsgrad η

Dabei handelt es sich um einen dimensionslosen Wert, der sich aus dem Verhältnis der Ausgangsleistung P_2 zur Eingangsleistung P_1 ergibt:

$$\eta = \frac{P_2}{P_1}$$

Il valore di rendimento di un singolo stadio di riduzione, in condizioni medie di velocità e coppia, è pari a 0.975; tale valore decresce nel caso di: incremento della velocità, diminuzione della coppia trasmessa, aumento della temperatura ambiente. Gli stadi angolari, di norma, sono caratterizzati da valori inferiori di rendimento.

The efficiency value of a single reduction stage under average speed and torque conditions, is equivalent to 0.975; this value decreases if: speed decreases, transmitted torque diminishes, ambient temperature increases. As a rule angular stages are characterised by inferior efficiency values.

Der Wert vom Wirkungsgrad einer einzelnen Untersetzungsstufe bei mittlerer Geschwindigkeit und Drehmoment entspricht 0.975. Dieser Wert nimmt bei zunehmender Geschwindigkeit, abnehmendem anliegendem Drehmoment und zunehmender Umgebungstemperatur ab. Die Winkelstufen sind in der Regel durch niedrigere Wirkungsgrade gekennzeichnet.

3.16 Fattore di servizio f_s

È un coefficiente moltiplicativo della coppia richiesta in uscita al riduttore, che tiene conto del tipo di servizio, della frequenza di avviamento e del numero di ore di funzionamento giornaliero.

In base alla macchina su cui va applicato il riduttore, si individua dalla tabella della classificazione delle applicazioni il tipo di servizio (uniforme, moderato o pesante). Successivamente si ottiene il valore del fattore di servizio dalla apposita tabella.

3.16 Service factor f_s

It is a multiplicative coefficient of the torque required in output from the reduction gear and takes into account the type of duty, start-up frequency and the number of hours of operation per day.

Depending on the machine the reduction gear is going to be mounted on, the type of service (uniform, moderate or heavy) can be found in the application classification table. You can then find the service factor from the relative table.

3.16 Betriebsfaktor f_s

Dabei handelt es sich um einen Multiplikationskoeffizienten des am Ausgang vom Planetengetriebe verlangten Drehmoment, der die Art vom Betrieb, die Startfrequenz und die Betriebsstunden pro Tag berücksichtigt.

Anhand der Maschine, in die das Planetengetriebe installiert wird, kann der Tabelle mit der Klassifikation der Anwendungen die Art vom Betrieb entnommen werden (gleichmäßig [u], gemäßigt [m] und schwer [h]). Aus der entsprechenden Tabelle kann anschließend der Betriebsfaktor entnommen werden.

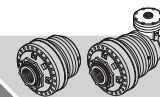

3.12 Facteur de durée à l'entrée/sortie $f_{h,1}, f_{h,2}$

Il s'agit du produit de la vitesse à l'entrée/sortie pour la durée exigée:

3.12 Factor de duración en entrada/salida $f_{h,1}, f_{h,2}$

Es el producto de la velocidad en entrada/salida por la duración requerida:

3.12 Fator de duração em entrada/saída $f_{h,1}, f_{h,2}$

É o produto da velocidade em entrada/saída pela duração necessária:

$$f_{h,1} = n_1 \cdot h_r \quad f_{h,2} = n_2 \cdot h_r$$

3.13 Puissance à l'entrée P_1 [kW]

Il s'agit de la puissance appliquée à l'entrée au réducteur, par la connexion directe ou indirecte (par le biais d'organes de transmission supplémentaires) d'un moteur.

3.13 Potencia en entrada P_1 [kW]

Es la potencia aplicada en entrada al reductor, mediante conexión directa o indirecta (con ulteriores órganos de transmisión) de un motor.

3.13 Potência em entrada P_1 [kW]

É a potência aplicada em entrada no reductor, mediante ligação direta ou indireta (com outros órgãos de transmissão) de um motor.

3.14 Puissance à la sortie P_2 [kW]

Il s'agit de la puissance exigée par l'utilisateur relié à la sortie du réducteur, qu'on peut calculer de la manière suivante:

3.14 Potencia en salida P_2 [kW]

Es la potencia requerida por el aparato usuario conectado con la salida del reductor. Se puede calcular como:

3.14 Potência em saída P_2 [kW]

É a potência requerida pelo usuário ligado em saída ao reductor. Pode ser calculada como:

$$P_2 = \frac{T_{2r} \cdot n_2}{9550}$$

3.15 Rendement η

Le rendement est un nombre adimensionnel, défini comme le rapport entre la puissance à la sortie P_2 et la puissance à l'entrée P_1 du réducteur:

3.15 Rendimiento η

Es un coeficiente adimensional dado por la relación entre la potencia en salida P_2 y aquella en entrada P_1 :

3.15 Rendimento η

É um número coeficiente dado pela relação entre a potência em saída P_2 e aquela em entrada P_1 :

$$\eta = \frac{P_2}{P_1}$$

La valeur du rendement d'un seul étage de réduction, dans des conditions moyennes de vitesse et de couple, équivaut à 0.975. Cette valeur décroît dans les cas suivants: augmentation de la vitesse, diminution du couple transmis, augmentation de la température ambiante. Les étages angulaires sont généralement caractérisés par des valeurs inférieures de rendement.

El valor de rendimiento de una etapa individual de reducción, en condiciones medias de velocidad y par, vale 0.975; dicho valor disminuye en caso de: aumento de la velocidad, disminución del par transmitido, aumento de la temperatura ambiente. Las etapas angulares, normalmente, se caracterizan por valores inferiores de rendimiento.

O valor de rendimento de apenas um estágio de redução, em condições médias de velocidade e par, é equivalente a 0.975; este valor decresce no caso de: incremento da velocidade, diminuição do par transmitido, aumento da temperatura ambiente. Os estádios angulares, geralmente, são caracterizados por valores inferiores de rendimento.

3.16 Facteur de service f_s

Il s'agit d'un coefficient multiplicatif du couple exigé à la sortie du réducteur, qui tient compte du type de service, de la cadence de démarrages et de la quantité d'heures de fonctionnement par jour. Suivant la machine sur laquelle le réducteur doit être appliqué, on peut trouver dans le tableau de la classification des applications, le type de service (uniforme, modéré ou lourd). Ensuite on obtient la valeur du facteur de service dans le tableau correspondant.

3.16 Factor de servicio f_s

Es un coeficiente multiplicador del par requerido en salida del reductor, que tiene en cuenta el tipo de servicio, la frecuencia de arranques y el número diario de horas de funcionamiento. Según la máquina en la cual se aplica el reductor, se individúa en la tabla de la clasificación de las aplicaciones el tipo de servicio (uniforme, moderado o pesado). Sucesivamente, se obtiene el valor del factor de servicio en la tabla correspondiente.

3.16 Fator de serviço f_s

É um coeficiente multiplicativo do par necessário em saída do reductor, que toma em consideração o tipo de serviço, a frequência de início de funcionamento e o número de horas de funcionamento por dia. Segundo o tipo de máquina na qual o reductor é aplicado, na tabela da classificação das aplicações pode-se identificar o tipo de serviço (uniforme, moderado ou pesado). Sucessivamente, na respetiva tabela obtém-se o valor do fator de serviço.

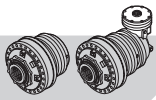

Compressori, ventilatori

Compressori assiali e radiali	U
Ventilatori a torre di raffreddamento	M
Ventilatori a tiraggio indotto	M
Compressori a pistoni rotanti	M
Compressori turbo	U

Industria chimica

Agitatori (materiali liquidi)	U
Agitatori (materiali semi-liquidi)	M
Centrifughe (pesanti)	M
Centrifughe (leggere)	U
Tamburi di raffreddamento	M
Tamburi di essiccazione	M
Miscelatori	M

Compressori

Compressori a pistone	H
Compressori turbo	M

Convogliatori

Nastro trasportatore a piastre	M
Sollevatori zavorra	M
Convogliatori nastro a sacca	M
Convogliatori a nastro (materie voluminose)	M
Convogliatori (merce a pezzi)	H
Convogliatori a tazza per farinacei	U
Convogliatori a catena	M
Convogliatori circolari	M
Montacarichi	H
Montacarichi inclinati	H
Convogliatore a nastro in acciaio	M
Sollevatori per persone	M
Trasportatori a coclea	M
Trasportatore a nastro concavo	M
Trasportatore a verricello	M

Gru

Meccanismo del braccio di trivellazione	M
Meccanismo di montacarico	U
Meccanismo rotante	M
Meccanismo di traslazione	H

Draghe

Convogliatori a tazza	H
Ruote a tazza	H
Teste portautensili	H
Verricelli per manovre	M
Pompe	M
Meccanismo rotante	M
Meccanismo di traslazione (mezzo cingolato)	H
Meccanismo di traslazione (rotaie)	M

Macchinari per industria alimentare

Macchine per il riempimento di bottiglie e contenitori	U
Frantumatori di canna	M
Coltelli per canna	H
Macina per canna	H
Impastatrice	H
Vasche per macerazione (cristallizzanti)	H
Cilindro essiccatore	H
Macchinari per imballaggio	U
Taglierine per barbabietole da zucchero	M
Macchine per il lavaggio di barbabietole da zucchero	M

Compressors, fans

<i>Axial and radial compressors</i>	U
<i>Cooling tower fans</i>	M
<i>Induced draft fans</i>	M
<i>Rotating piston compressors</i>	M
<i>Turbo compressors</i>	U

Chemical Industry

<i>Stirrers (liquid materials)</i>	U
<i>Stirrers (semi-liquid materials)</i>	M
<i>Centrifugal machines (heavy)</i>	M
<i>Centrifugal machines (light)</i>	U
<i>Cooling drums</i>	M
<i>Drying drums</i>	M
<i>Mixers</i>	M

Compressors

<i>Piston compressors</i>	H
<i>Turbo compressors</i>	M

Conveyors

<i>Slat conveyor</i>	M
<i>Ballast hoister</i>	M
<i>Pocket conveyor belt</i>	M
<i>Conveyor belt (bulky material)</i>	M
<i>Conveyor (goods in pieces)</i>	H
<i>Bucket conveyor for flours</i>	U
<i>Chain conveyor</i>	M
<i>Circular conveyor</i>	M
<i>Hoists</i>	H
<i>Inclined hoist</i>	H
<i>Steel conveyor belt</i>	M
<i>Lifts for people</i>	M
<i>Screw conveyor</i>	M
<i>Concave belt conveyor</i>	M
<i>Winch conveyor</i>	M

Cranes

<i>Mechanism of the drilling arm</i>	M
<i>Hoist mechanism</i>	U
<i>Rotating mechanism</i>	M
<i>Translation mechanism</i>	H

Dredges

<i>Bucket conveyor</i>	H
<i>Bucket wheels</i>	H
<i>Tool-holding heads</i>	H
<i>Winches for manoeuvres</i>	M
<i>Pumps</i>	M
<i>Rotating mechanism</i>	M
<i>Translation mechanism (tracked vehicle)</i>	H
<i>Translation mechanism (rails)</i>	M

Machinery for the food industry

<i>Machines for filling bottles and containers</i>	U
<i>Cane crushers</i>	M
<i>Knives for cane</i>	H
<i>Cane mill</i>	H
<i>Kneading machine</i>	H
<i>Tanks for macerating (crystallizers)</i>	H
<i>Drying cylinder</i>	H
<i>Packing machinery</i>	U
<i>Cutters for sugar beet</i>	M
<i>Machines for washing sugar beet</i>	M

Kompressoren, Gebläse

Axial- und Radialkompressoren	U
Kühlurmgebläse	M
Gebläse mit Induktionszug	M
Rotationskolbenkompressoren	M
Turbokompressoren	U

Chemische Industrie

Rührwerke (flüssige Stoffe)	U
Rührwerke (halbfüssige Stoffe)	M
Zentrifugen (schwer)	M
Zentrifugen (leicht)	U
Kühltrommeln	M
Trocknungstrommeln	M
Mischer	M

Kompressoren

Kolbenkompressoren	H
Turbokompressoren	M

Förderer

Plattenförderband	M
Ballastheber	M
Sackförderband	M
Förderband voluminöse Materialien)	M
Förderer (lose Waren)	H
Becherförderwerke	U
Kettenförderer	M
Kreiselförderer	M
Lastenaufzüge	H
Geneigte Lastenaufzüge	H
Förderbänder aus	M
Personenhebevorrichtungen	M
Schneckenförderer	M
Hohlbandförderer	M
Windenförderer	M

Kräne

Mechanik des Bohrarms	M
Mechanik des Lastenhebers	U
Rotationsmechanik	M
Translationsmechanik	H

Nassbagger

Becherförderwerke	H
Becherrad	H
Werkzeugkopfe	H
Manöverwinden	M
Pumpen	M
Rotationsmechanik	M
Translationsmechanik (Raupenfahrzeug)	H
Translationsmechanik (Schiene)	M

Maschinen für die Lebensmittelindustrie

Maschine zum Füllen von Flaschen und Behältern	U
Zuckerrohrbrecher	M
Messer für Zuckerrohr	H
Mühle für Zuckerrohr	H
Knetmaschine	H
Veinweichbecken (kristallisierend)	H
Trocknungszylinder	H
Verpackungsmaschine	U
Schneidemaschinen für Zuckerrüben	M
Waschmaschinen für Zuckerrüben	M

**Compresseurs, ventilateurs**

Compresseurs axiaux et radiaux	U
Ventilateurs à tour de refroidissement	M
Ventilateurs à tirage induit	M
Compresseurs à pistons rotatifs	M
Compresseurs turbo	U

Industrie chimique

Agitateurs (matériaux liquides)	U
Agitateurs (matériaux semi-liquides)	M
Centrifuges (lourdes)	M
Centrifuges (légères)	U
Tambours de refroidissement	M
Tambours de séchage	M
Mélangeurs	M

Compresseurs

Compresseurs à piston	H
Compresseurs turbo	M

Convoyeurs

Tapis transporteur à plaques	M
Élévateurs lest	M
Convoyeurs à bande à poches	M
Convoyeurs à bande (matières volumineuses)	M
Convoyeurs (marchandise par pièces)	H
Conv. à godets pour substances farinacées	U
Convoyeurs à chaîne	M
Convoyeurs circulaires	M
Monte-charge	H
Monte-charge inclinés	H
Convoyeur à bande en acier	M
Élévateurs pour personnes	M
Transporteurs à vis sans fin	M
Transporteur à bande concave	M
Transporteur à treuil	M

Grues

Mécanisme du bras de forage	M
Mécanisme de monte-charge	U
Mécanisme rotatif	M
Mécanisme de déplacement	H

Dragues

Convoyeurs à godets	H
Roues à godets	H
Têtes porte-outils	H
Treuil pour manœuvre	M
Pompes	M
Mécanisme rotatif	M
Mécanisme de déplacement (véhicules chenillés)	H
Mécanisme de déplacement (rails)	M

Outillages pour industrie alimentaire

Machines pour le remplissage de bouteilles et récipients divers	U
Broyeurs de canne	M
Lames pour canne	H
Meule pour canne	H
Pétrisseuse	H
Bacs pour la macération (cristallisants)	H
Cylindre de séchage	H
Appareils pour l'emballage	U
Cisailles pour betteraves à sucre	M
Machines pour le lavage de betteraves à sucre	M

Compresores, ventiladores

Compresores axiales y radiales	U
Ventiladores en torre de refrigeración	M
Ventiladores de tiro inducido	M
Compresores de émbolos giratorios	M
Compresores turbo	U

Industria química

Agitadores (materiales líquidos)	U
Agitadores (materiales semilíquidos)	M
Centrifugas (pesadas)	M
Centrifugas (ligeras)	U
Tambores de refrigeración	M
Tambores de secado	M
Mezcladores	M

Compresores

Compresores de émbolo	H
Compresores turbo	M

Transportadores

Cinta transportadora de placas	M
Elevadores lastre	M
Transportadores de cinta de saco	M
Transportadores de cinta (materias voluminosas)	M
Transportadores (mercancía en trozos)	H
Transportadores de cangilones para harinas	U
Transportadores de cadena	M
Carruseles	M
Montacargas	H
Montacargas inclinados	H
Transportadores de cinta en acero	M
Elevadores para personas	M
Transportadores de cóclea	M
Transportadores de cinta cóncava	M
Transportadores de cabrestante	M

Grúas

Mecanismo del brazo de perforación	M
Mecanismo de montacargas	U
Mecanismo giratorio	M
Mecanismo de traslación	H

Dragas

Transportadores de cangilones	H
Ruedas de cangilones	H
Cabezales portaherramientas	H
Cabrestantes para maniobras	M
Bombas	M
Mecanismo giratorio	M
Mecanismo de traslación (medio con orugas)	H
Mecanismo de traslación (raíles)	M

Maquinarias para industria alimentaria

Máquinas para llenar botellas y contenedores	U
Machacadoras de caña	M
Cuchillos para caña	H
Muela para caña	H
Amasadora	H
Cubas para rendido (cristalizantes)	H
Cilindro secador	H
Máquinas para embalaje	U
Cortadoras para remolachas	M
Máquinas para lavar remolachas	M

Compresores, ventiladores

Compresores axiais e radiais	U
Ventiladores a torre de arrefecimento	M
Ventiladores de ação induzida	M
Compresores de pistões rotativos	M
Compresores turbo	U

Indústria química

Agitadores (materiais líquidos)	U
Agitadores (materiais semi-líquidos)	M
Centrifugadoras (pesadas)	M
Centrifugadoras (ligeiras)	U
Tambores de arrefecimento	M
Tambores de secagem	M
Misturadores	M

Compresores

Compresores a pistão	H
Compresores turbo	M

Canalizadores

Tapete transportador de chapas	M
Levantadores lastro	M
Canalizadores tapete de saco	M
Canalizadores a tapete (matérias volumosas)	M
Canalizadores (mercadorias a granel)	H
Canalizadores de taça para farináceos	U
Canalizadores de cadeia	M
Canalizadores circulares	M
Elevadores	H
Elevadores inclinados	H
Canalizador a tapete de aço	M
Levantadores para pessoas	M
Transportadores de parafuso	M
Transportador de tapete concavo	M
Transportador com guincho	M

Gruas

Mecanismo do braço de trivelar	M
Mecanismo de monta-cargas	U
Mecanismo rotativo	M
Mecanismo de translação	H

Dragas

Canalizadores de balde	H
Rodas de balde	H
Cabeças para utensílios	H
Guinchos para manobras	M
Bombas	M
Mecanismo rotativos	M
Mecanismo de translação (meio com lagartas)	H
Mecanismo de translação (carris)	M

Máquinas para a indústria alimentar

Máquinas para enchimento de garrafas e recipientes	U
Moinhos de cana	M
Facas para cana	H
Moinhos para cana	H
Máquinas de empastar	H
Tanques para maceração (cristalizadores)	H
Cilindro secador	H
Máquinas de embalar	U
Cortadoras beterraba de açúcar	M
Máquinas para lavagem de de beterrabas de açúcar	M

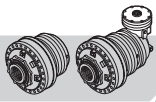
Macchinari per costruzione

Betoniere	M
Montacarichi	M
Macchinari per costruzione strade	M

Generatori e trasformatori

Trasformatori di frequenza	H
Generatori	H
Generatori per saldatrici	H

Lavanderie

Invertitori	M
Lavatrici	M
Stiratrici	M

Laminatoi per metalli

Cesoie per laminatoi	H
Trasmissioni a catena	M
Laminatoi a freddo	H
Impianti per fusione continua	H
Basamenti refrigeranti	M
Cesoie per spuntatura	H
Laminatoi per piatti medi e pesanti	H
Treni sbozzatori e lingotti	H
Manipolatori	H
Trancia lamiere	H
Raddrizzatore rulli	M
Tavole a rulli (pesante)	H
Tavole a rulli (leggere)	H
Macchine saldatrici a tubo	M
Macchine avvolgitrici (guarnizioni fili)	M
Banchi da disegno a filo	M

Macchine per la lavorazione del metallo

Contraalberi, alberi in linea	U
Pressa per stampaggio a caldo	H
Martelli	H
Guide ausiliarie, macchine utensili	U
Guide principali, macchine utensili	M
Macchine per la piallatura di metalli	H
Raddrizzatrice per la lamiera	H
Pressa	H
Pressa per stampi	H
Cesoie	M
Macchine per piegatrici di metalli	M

Industria petrolifera

Pompe conduttrici	M
Attrezzatura trapanatrice rotante	H

Macchine per la carta

Calandre	H
Manicotto	H
Tamburo essiccatore	H
Raffinatrice	H
Sfibratore per pasta	H
Rulli aspiranti	H
Pressa aspiranti	H
Pressa a umido	H
Battitoi	H

Macchine per la plastica

Calandre	M
Frantoi	M
Estrusori	M
Miscelatori	M

Building machinery

Concrete mixers	M
Hoists	M
Machinery for road construction	M

Generators and transformers

Frequency transformers	H
Generators	H
Generators for welding machine	H

Laundries

Inverters	M
Washing machines	M
Ironing machines	M

Metal rollers

Shears for rolling mills	H
Chain drives	M
Cold rolling mills	H
Plants for continuous milling	H
Cooling blocks	M
Shears for discarding	H
Rolling mills for medium and heavy plates	H
Roughing mills and ingots	H
Mechanical hands	H
Sheet shears	H
Roller rectifier	M
Roller tables (heavy)	H
Roller tables (light)	H
Tube-welding machines	M
Winding machines (wire washer)	M
Flush drawing boards	M

Machines for working metal

Counter shafts, shafts in line	U
Press for hot-pressing	H
Hammers	H
Auxiliary guides, machine tools	U
Main guides, machine tools	M
Machine for metal planing	H
Rectifier for metal sheet	H
Presses	H
Presses for forging	H
Shears	M
Machine for folding metals	M

Petrol industry

Conveying pumps	M
Rotating drill equipment	H

Machines for paper

Rolling presses	H
Coupling	H
Drying drum	H
Beater	H
Grinder for pulp	H
Suction rollers	H
Suction presses	H
Wet presses	H
Willows	H

Machines for plastic

Rolling presses	M
Grinders	M
Extruders	M
Mixers	M

Baummaschinen

Betonmischer	M
Lastenaufzüge	M
Straßenbaumaschine	M

Generatoren und Transformatoren

Frequenztransformatoren	H
Generatoren	H
Generatoren für Schweißmaschinen	H

Wäschereien

Umkehrsysteme	M
Waschmaschinen	M
Bügelmaschinen	M

Metallwalzstraßen

Scheren für Walzstraßen	H
Kettenantrieb	M
Kaltwalzstraßen	H
Schmelzmaschine für Dauerbetrieb	H
Kühlunterbauten	M
Schopfscheren	H
Walzstraßen für mittelschwere und schwere Bleche	H
Vorschmiedezüge und Barren	H
Manipulatoren	H
Blechscherer	H
Rollengleichrichter	M
Rollentische (schwer)	H
Rollentische (leicht)	H
Rohrschweißmaschinen	M
Wickelmaschinen (Kabelhüllen)	M
Zeichentische	M

Maschinen für die Metallbearbeitung Industrie

Gegenwellen, Welle in Linie	U
Pressa für Heißstanzung	H
Hämmer	H
Zusatzführungen, Werkzeugmaschinen	U
Hauptführungen, Werkzeugmaschinen	M
Hobelmaschinen für Metall	H
Gleichrichter für Bleche	H
Pressen	H
Stanzpressen	H
Scheren	M
Metallbiegemaschinen	M

Petrochemische Industrie

Leitungspumpen	M
Ausrüstung für Rotationsbohrmaschinen	H

Maschinen für die Papierherstellung

Kalander	H
Muffe	H
Trocknungstrommel	H
Feinzeugholländer	H
Zerfaserer	H
Saugwalzen	H
Saugpresse	H
Feuchtpresse	H
Wolf	H

Maschinen für die Kunststoffherstellung

Kalander	M
Brecher	M
Extruder	M
Mischer	M

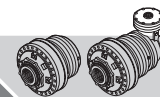
**Outillages pour construction**

Bétonnières	M
Monte-charge	M
Outillages pour la construction des routes	M

Générateurs et transformateurs

Transformateurs de fréquence	H
Générateurs	H
Générateurs pour soudeuses	H

Teintureries

Inverseurs	M
Machines à laver	M
Repasseuses	M

Lamineurs pour métaux

Cisailles pour laminaires	H
Transmissions à chaîne	M
Laminaires à froid	H
Installations pour la fusion continue	H
Carters réfrigérants	M
Cisailles pour chute	H
Laminaires pour plateaux moyens et lourds	H
Trains ébaucheurs et lingots	H
Manipulateurs	H
Découpeuse de tôles	H
Redresseur de rouleaux	M
Planches à rouleaux (lourdes)	H
Planches à rouleaux (légères)	H
Soudeuses à tube	M
Enrouleuses (joints fils)	M
Planches à dessin à fil	M

Outillages pour l'usinage du métal

Contre-arbres, arbres en ligne	U
Presse pour moulage à chaud	H
Marteaux	H
Glissières auxiliaires, machines-outils	U
Glissières principales, machines-outils	M
Machines pour le rabotage de métaux	H
Redresseur pour la tôle	H
Presses	H
Presses pour moules	H
Cisailles	M
Machines pour cintreuses de métaux	M

Industrie pétrolière

Pompes à conduction	M
Appareils de forage rotatifs	H

Machines pour le papier

Calandres	H
Manchon	H
Tambour de séchage	H
Raffineuse	H
Défibreur pour pâte	H
Rouleaux aspirants	H
Presses aspirantes	H
Presses par voie humide	H
Batteurs	H

Machines pour le plastique

Calandres	M
Broyeurs	M
Extrudeuses	M
Mélangeurs	M

Máquinas para construcciones

Hormigoneras	M
Montacargas	M
Máquinas para construir carreteras	M

Generadores y transformadores

Transformadores de frecuencia	H
Generadores	H
Generadores para equipos de soldar	H

Lavanderías

Inversores	M
Lavadoras	M
Planchadoras	M

Laminadores para metales

Cizallas para laminadores	H
Transmisiones por cadena	M
Laminadores en frío	H
Plantas para fundición continua	H
Bancadas refrigeradoras	M
Cizallas para despunte	H
Laminadores para piezas planas medias y pesadas	H
Trenes desbastadores y lingotes	H
Manipuladores	H
Cizalla para planchas	H
Rectificador de rodillos	M
Tablas de rodillos (pesadas)	H
Tablas de rodillos (ligeras)	H
Máquinas para soldar de tubos	M
Máquinas bobinadoras (juntas hilos)	M
Bancos de dibujo de hilo	M

Máquinas para trabajar metales

Contraejes, ejes en línea	U
Presse para embutir en caliente	H
Martillos	H
Guías auxiliares, máquinas herramientas	U
Guías principales, máquinas herramientas	M
Máquinas para acepillar metales	H
Enderezadora para plancha	H
Pressas	H
Pressas para moldes	H
Cizallas	M
Máquinas para plegadoras de metales	M

Industria petrolera

Bombas conductoras	M
Equipo perforador giratorio	H

Máquinas para papel

Calandrias	H
Manguito	H
Tambor secador	H
Refinadora	H
Desfibradora para pasta	H
Rodillos aspiradores	H
Pressas aspiradoras	H
Pressas en húmedo	H
Batanes	H

Máquinas para plástico

Calandrias	M
Lagares	M
Extrudidoras	M
Mezcladoras	M

Máquinas para construção

Betoneiras	M
Elevadores	M
Máquinas para a construção estradas	M

Geradores e transformadores

Transformadores de frequência	H
Geradores	H
Geradores para soldadoras	H

Lavandarias

Inversores	M
Máquinas de lavar	M
Máquinas de passar a ferro	M

Laminadores para metais

Tesouras para laminadores	H
Transmissões de cadeia	M
Laminadores a frio	H
Instalações para fusão continua	H
Bases refrigeradoras	M
Tesouras para despontar	H
Laminadores para pratos médios e pesados	H
Trens desboçar e lingotes	H
Manipuladores	H
Cortadoras de chapa	H
Endireitadores rolos	M
Mesas de rolos (pesadas)	H
Mesas de rolos (ligeiras)	H
Máquinas de soldar de tubo	M
Máquinas enroladoras (juntas fios)	M
Bancos de desenho a fio	M

Máquinas para a laboração de metais

Contra-veios e veios em linha	U
Presse para moldagem a quente	H
Martelos	H
Guias auxiliares, máquinas utensílios	U
Guias principais, máquinas utensílios	M
Máquinas para plainar metais	H
Endireitadoras para chapas	H
Pressas	H
Pressas para moldes	H
Tesouras	M
Máquinas de quinar metais	M

Indústria petrolífera

Bombas conductoras	M
Equipamento de trivelação rotativo	H

Máquinas per a carta

Calandras	H
Manguito	H
Tambor secador	H
Refinadora	H
Desfibrador para massa	H
Rolos aspiradores	H
Pressas aspiradoras	H
Pressas a húmido	H
Batedores	H

Máquinas para plásticos

Calandras	M
Moinhos	M
Extrusores	M
Misturadores	M

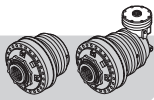

Pompe	
Pompa centrifuga (liquidi leggeri)	U
Pompa centrifuga (liquidi viscosi)	H
Pompe a pistoni	H
Pompe a pulsante	H
Pompe a pressione	H

Pumps	
Centrifugal pump (light liquids)	U
Centrifugal pump (viscose liquids)	H
Piston pumps	H
Pushbutton pump	H
Pressure pump	H

Pumpen	
Zentrifugalpumpe (leichte Flüssigkeiten)	U
Zentrifugalpumpe (viskose Flüssigkeiten)	H
Kolbenpumpen	H
Tastenspumpen	H
Druckpumpen	H

Macchinari	
Calandre	M
Estrusori	H
Miscelatori	M
Impastatrici	H
Laminatoi	H

Machinery for rubber	
Rolling presses	M
Extruders	H
Mixers	M
Kneading machines	H
Rolling mills	H

Maschinen für die Gummiherstellung	
Kalander	M
Extruder	H
Mischer	M
Knetmaschinen	H
Walzstraßen	H

Macchine per la lavorazione della pietra e dell'argilla	
Mulino a martelli	H
Laminatoi per raffinare	H
Interruttore	H
Presse per mattoni	H
Forno rotante	H
Laminatoi a tubo	H

Machines for working stone and clay	
Hammer mills	H
Rolling mills for refining	H
Switch	H
Presses for bricks	H
Rotating kiln	H
Tube rolling mills	H

Maschinen für die Verarbeitung von Stein und Ton	
Hammermühle	H
Feinzeugholländer	H
Schalter	H
Ziegelpressen	H
Rotationsöfen	H
Strangextruder	H

Macchine tessili	
Dosatori	M
Telai per tessitura	M
Macchine per la stampa e la tintura	M
Vasca per la concia	M
Battitoi	M

Textile machines	
Batchers	M
Looms for weaving	M
Machines for printing and dyeing	M
Tank for tanning	M
Willows	M

Maschinen für die Textilindustrie	
Dosiervorrichtungen	M
Webrahmen	M
Druck- und Färbemaschinen	M
Gerbebecken	M
Wolf	M

Trattamenti ad acqua	
Aeratori	M
Pompa a vite	M

Water treatments	
Aerators	M
Screw pump	M

Wasserbehandlung	
Lüfter	M
Schraubenpumpen	M

Macchine per la lavorazione del legno	
Scortecciatrici	H
Macchine per la piallatura	M
Telaio per seghe	H
Macchine per la lavorazione del legno	U

Machines for working wood	
Bark-peeling machines	H
Planing machines	M
Frame for saws	H
Machines for working wood	U

Maschinen für die Holzverarbeitende Industrie	
Schälmaschinen	H
Hobelmaschinen	M
Rahmen für Sägen	H
Maschine für die Holzverarbeitung	U

f _s		U Uniform Gleichmäßig			M Moderato Gemäßigt			H Pesante Heavy Schwer		
		Ore di funzionamento giornaliere / Hours of operation per day / Betriebsstunde pro Tag								
		<1	1 ÷ 8	8 ÷ 24	<1	1 ÷ 8	8 ÷ 24	<1	1 ÷ 8	8 ÷ 24
N° avviamenti/ora No. of start-ups/hour Anzahl Startvorgänge/ Stunde	< 6	0.7	0.9	1.1	0.9	1.1	1.3	1	1.3	1.7
	6 ÷ 60	0.9	1.2	1.4	1.1	1.4	1.6	1.4	1.7	2
	> 60	1.2	1.5	1.7	1.4	1.7	2	1.7	2.1	2.5

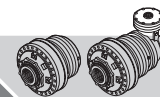

Pompes	
Pompe centrifuge (liquides légers)	U
Pompe centrifuge (liquides visqueux)	H
Pompes à pistons	H
Pompes à touche	H
Pompes à pression	H

Outillages pour le caoutchouc	
Calandres	M
Extrudeuses	H
Mélangeurs	M
Pétrisseuses	H
Laminoirs	H

Machines pour l'usinage de la pierre et de l'argile	
Moulins à marteaux	H
Laminoirs pour ennobrir	H
Interrupteur	H
Presses pour briques	H
Four rotatif	H
Laminoirs à tube	H

Machines textiles	
Doseurs	M
Métiers à tisser	M
Machines pour l'impression et la finition	M
Bac pour le traitement des fibres	M
Batteurs	M

Traitements à eau	
Aérateurs	M
Pompe à vis	M

Machines pour le travail du bois	
Ecorceuses	H
Machines pour le rabotage	M
Châssis pour scies	H
Machines pour le travail du bois	U

Bombas	
Bomba centrífuga (líquidos ligeros)	U
Bomba centrífuga (líquidos viscosos)	H
Bombas de émbolos	H
Bombas de pulsión	H
Bombas de presión	H

Máquinas para caucho	
Calandrias	M
Extrudidoras	H
Mezcladoras	M
Amasadoras	H
Laminadoras	H

Máquinas para labrar piedras y tratar arcillas	
Molino de martillos	H
Laminador para refinar	H
Interruptor	H
Presas para ladrillos	H
Horno giratorio	H
Laminadores de tubo	H

Máquinas textiles	
Dosificadores	M
Telares	M
Máquinas para estampar y teñir	M
Cubas para curtir	M
Batanes	M

Tratamiento con agua	
Ventiladores	M
Bomba de caracol	M

Máquinas para labrar la madera	
Descortezadoras	H
Máquinas de acepillar	M
Bastidor para sierras	H
Máquinas para labrar la madera	U

Bombas	
Bomba centrífuga (líquidos ligeiros)	U
Bomba centrífuga (líquidos viscosos)	H
Bombas a pistões	H
Bombas a botão	H
Bombas a pressão	H

Máquinas para borracha	
Calandras	M
Extrusores	H
Misturadores	M
Máquinas de empastar	H
Laminadores	H

Máquinas para laboração de pedras e argila	
Moinho de martelos	H
Laminadores para refinar	H
Interruptor	H
Pressas para tijolos	H
Forno rotativo	H
Laminadores a tubo	H

Máquinas têxteis	
Dosadores	M
Chassis para tecelagem	M
Máquinas de estampar e tingir	M
Tanques para curtumes	M
Batedores	M

Tratamentos de água	
Arejadores	M
Bomba de parafuso	M

Máquinas para laboração da madeira	
Máquina de descascar troncos	H
Plainas	M
Chassis para serras	H
Máquinas para a transformação de madeira	U

f_s		U Uniforme Uniforme			M Modéré Moderado			H Lour Pesado Pesado		
		Heures de fonctionnement par jour / Horas de funcionamiento al día / Horas de funcionamento ao dia								
		<1	1 ÷ 8	8 ÷ 24	<1	1 ÷ 8	8 ÷ 24	<1	1 ÷ 8	8 ÷ 24
Q.té de mise en service/heure Nº arranques/hora Nº entradas em serviço/hora	< 6	0.7	0.9	1.1	0.9	1.1	1.3	1	1.3	1.7
	6 ÷ 60	0.9	1.2	1.4	1.1	1.4	1.6	1.4	1.7	2
	> 60	1.2	1.5	1.7	1.4	1.7	2	1.7	2.1	2.5

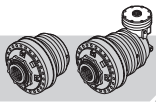

3.17 Potenza termica P_t [kW]

La potenza termica è quella potenza che, applicata in entrata al riduttore in funzionamento continuo prolungato, stabilizza la temperatura dell'olio all'interno del riduttore a 90°C, nelle seguenti condizioni di prova:

- velocità in entrata 1000 min⁻¹;
- lubrificazione per sbattimento;
- riduttore in posizione orizzontale non soggetto a ricircolo d'aria;
- quantità di olio corrispondente a metà riempimento;
- olio minerale ISO VG 150;
- temperatura ambiente 20°C.

Il valore della potenza termica di ciascun riduttore è riportato nella relativa tabella dei dati tecnici.

Per condizioni differenti da quelle sopra specificate il valore della potenza termica va corretto, come spiegato più avanti.

In presenza di un freno negativo (in condizioni di funzionamento continuo), la temperatura dell'olio all'interno del riduttore è soggetta ad un continuo innalzamento.



Il montaggio del riduttore in un vano di dimensioni ridotte diminuisce notevolmente la capacità di smaltimento della potenza termica.

Se la potenza applicata in ingresso al riduttore dovesse superare il valore di potenza termica ammissibile o comunque il riduttore si trovasse a operare in un vano di ridotte dimensioni o con scarso ricircolo d'aria, si consiglia di impiegare un sistema ausiliario di raffreddamento a ricircolo d'olio.

3.18 Carico radiale in entrata/uscita $F_{r,1}$, $F_{r,2}$

In corrispondenza delle entrate veloci tipo leggera, media e pesante e dei supporti uscita MS, MC, ZI sono riportate le curve del carico radiale ammissibile $F_{r,1}$ o $F_{r,2}$ in funzione della ascissa x (distanza da un riferimento opportuno).

Il valore di carico radiale ammissibile è riferito ad una durata dei cuscinetti, calcolata in base alla norma ISO 281, pari rispettivamente a:

- $10^7 n_1 \cdot h$ per gli alberi entrata;
- $10^5 n_2 \cdot h$ per gli alberi uscita

3.17 Thermal power P_t [kW]

Thermal power is the power that, applied at input to the continuously working reduction gear, stabilises the temperature of the oil inside the reduction gear at 90°C under the following test conditions:

- *input speed: 1000 min⁻¹;*
- *oil splash lubrication;*
- *reduction gear in a horizontal position not subject to air recirculation;*
- *quantity of oil corresponding to the half full mark;*
- *ISO VG 150 mineral oil;*
- *ambient temperature 20°C.*

The value of the thermal power of each reduction gear is given in the relative technical data table.

For conditions differing from those described above, the thermal power value has to be corrected as explained further on.

When we have a negative brake (in continuous duty conditions), the temperature of oil inside the reduction gear keeps rising.

Mounting the reduction gear inside a small compartment reduces thermal power dispersion capacity considerably.

If the power applied in input to the reduction gear exceeds the permitted thermal power or if the reduction gear is working inside a small compartment or with only a small change of air, we suggest an oil recirculation type cooling circuit.

3.18 Input/output radial load $F_{r,1}$, $F_{r,2}$

The curves of the permitted radial load $F_{r,1}$ or $F_{r,2}$ as a function of abscissa x (distance from a suitable reference) are given where the fast inputs (light, medium and heavy types) and output supports MS, MC, ZI are.

The permitted radial load value refers to a duration of the bearings calculated on the basis of the ISO 281 standard and equivalent to, respectively:

- *$10^7 n_1 \cdot h$ for the input shafts;*
- *$10^5 n_2 \cdot h$ for the output shafts*

3.17 Wärmeleistung P_t [kW]

Die Wärmeleistung ist der Wert, der – angewendet am Eingang der Untersetzung bei längerem Dauerbetrieb – die Temperatur des Öls im Inneren vom Planetengetriebe unter den folgenden Testbedingungen auf 90°C stabilisiert:

- Eingangsgeschwindigkeit 1000 min⁻¹;
- Schlagschmierung;
- Untersetzung in horizontaler Lage und nicht der Luftzirkulation ausgesetzt;
- Ölmenge, die der halben Füllung entspricht;
- Mineralöl ISO VG 150;
- Umgebungstemperatur 20°C.

Der Wert der Wärmeleistung der einzelnen Planetengetriebe ist in der Tabelle mit den technischen Daten aufgeführt.

Bei Bedingungen, die von den oben genannten abweichen, muss der Wert der Wärmeleistung korrigiert werden, wie im Folgenden noch erläutert wird.

Wenn eine Negativbremse vorhanden ist (bei Dauerbetrieb), steigt die Temperatur vom Öl im Planetengetriebe ständig an.

Die Montage vom Planetengetriebe in einem Fach mit reduzierten Abmessungen reduziert die Fähigkeit zur Ableitung der Wärmeleistung.

Falls die am Eingang vom Planetengetriebe anliegende Leistung die zulässige Wärmeleistung übersteigt oder falls das Planetengetriebe in einem Fach mit reduzierten Abmessungen oder schlechter Luftzirkulation montiert wird, muss eine Ölkühlung installiert werden.

3.18 Querlast am Eingang/Ausgang $F_{r,1}$, $F_{r,2}$

Bezogen auf schnelle Eingänge vom Typ leicht, mittel und schwer und Lager am Ausgang MS, MC, ZI sind die Kurven der zulässigen Querlast $F_{r,1}$ oder $F_{r,2}$ auf der X-Achse abgetragen (Abstand von einem geeigneten Bezugspunkt).

Der Wert der zulässigen Querlast bezieht sich auf eine Lebensdauer der Lager, die nach Vorgabe der Norm ISO 281 berechnet wird, und zwar:

- $10^7 n_1 \cdot h$ für Eingangswellen;
- $10^5 n_2 \cdot h$ für Ausgangswellen

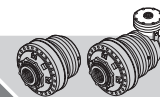
**3.17 Puissance thermique** **P_t [kW]**

La puissance thermique est la puissance qui, appliquée à l'entrée au réducteur en marche continue prolongée, stabilise la température de l'huile à l'intérieur du réducteur à 90°C, dans les conditions d'essai suivantes:

- vitesse à l'entrée 1000 min⁻¹;
- lubrification par barbotage ;
- réducteur en position horizontale non sujette à recirculation d'air;
- quantité d'huile correspondant à un nourrissage à mi-hauteur;
- huile minérale ISO VG 150;
- température ambiante 20°C.

La valeur de la puissance thermique de chaque réducteur est indiquée sur le tableau des caractéristiques techniques.

Pour des conditions différentes de celles qui sont indiquées ci-dessus, la valeur de la puissance thermique doit être corrigée (voir explications plus loin).

En présence d'un frein négatif (dans des conditions de service continu), la température de l'huile à l'intérieur du réducteur est sujette à une hausse continue.



Le montage du réducteur dans un espace de petites dimensions réduit considérablement la capacité d'évacuation de la puissance thermique.

Si la puissance appliquée à l'entrée du réducteur devait dépasser la valeur de puissance thermique admissible ou si le réducteur devait fonctionner dans un espace de petites dimensions ou avec une faible recirculation d'air, il est recommandé d'employer un circuit auxiliaire de refroidissement à recirculation d'huile.

3.18 Charge radiale à l'entrée/à la sortie **$F_{r,1}, F_{r,2}$**

À l'endroit des entrées rapides de type léger, moyen ou lourd et des supports à la sortie MS, MC, ZI se trouvent les courbes de la charge radiale admissible $F_{r,1}$ ou $F_{r,2}$ en fonction de l'abscisse x (distance d'un repère adéquat).

La valeur de charge radiale admissible se rapporte à une durabilité des roulements, calculée conformément à la norme ISO 281, correspondant, respectivement à:

- $10^7 n_1 \cdot h$ pour les arbres à l'entrée;
- $10^5 n_2 \cdot h$ pour les arbres à la sortie

3.17 Potencia térmica **P_t [kW]**

La potencia térmica es la potencia que, aplicada en la entrada del reductor en funcionamiento continuo prolongado, estabiliza la temperatura del aceite dentro del reductor en 90°C, en las siguientes condiciones de prueba:

- velocidad en entrada : 1000 min⁻¹;
- lubricación por circulación y salpicadura;
- reductor en posición horizontal no sujeto a recirculación de aire;
- cantidad de aceite correspondiente a medio llenado;
- aceite mineral ISO VG 150;
- temperatura ambiente 20°C.

El valor de la potencia térmica de cada reductor se indica en la correspondiente tabla de los datos técnicos.

Para condiciones distintas de las especificadas más arriba, se debe corregir el valor de la potencia térmica, como explicado más adelante.

En presencia de un freno negativo (en condiciones de funcionamiento continuo), la temperatura del aceite dentro del reductor está sujeta a una subida continua.

El montaje del reductor en un espacio de medidas reducidas disminuye notablemente la capacidad de eliminación de la potencia térmica.

Si la potencia aplicada en la entrada del reductor superara el valor de potencia térmica admitido o de todas maneras el reductor trabajara en un espacio de medidas reducidas o con escasa recirculación de aire, se aconseja utilizar un sistema auxiliar de refrigeración por recirculación de aceite.

3.18 Carga radial en entrada/salida **$F_{r,1}, F_{r,2}$**

En correspondencia con las entradas rápidas de tipo ligero, medio y pesado y de los soportes de salida MS, MC, ZI se presentan las curvas de la carga radial admitida $F_{r,1}$ ó $F_{r,2}$ en función de la abscisa x (distancia con respecto a una oportuna referencia).

El valor de carga radial admitida se refiere a una duración de los cojinetes, calculada según la norma ISO 281, equivalente respectivamente a:

- $10^7 n_1 \cdot h$ para los ejes de entrada;
- $10^5 n_2 \cdot h$ para los ejes de salida

3.17 Potência térmica **P_t [kW]**

A potência térmica é a potência que, aplicada em entrada no redutor em funcionamento contínuo prolongado, estabiliza a temperatura do óleo no interior do redutor a 90°C, nas seguintes condições de prova:

- velocidade em entrada 1000 min⁻¹;
- lubrificação por batimento;
- redutor em posição horizontal não sujeito a recirculação do ar;
- quantidade de óleo correspondente a meio enchimento;
- óleo mineral ISO VG 150;
- temperatura ambiente 20°C.

O valor da potência térmica de cada reductor é indicado na relativa tabela dos dados técnicos.

Para condições diferentes daquelas acima especificadas o valor da potência térmica deve ser corrigido, como referido mais adiante.

Na presença de um freio negativo (em condições de funcionamento contínuo), a temperatura do óleo no interior do reductor é sujeita a aumento contínuo.

A montagem do reductor num ambiente de dimensões reduzidas diminui notablemente a capacidade de eliminação da potência térmica.

Se a potência aplicada em entrada no reductor superará o valor de potência térmica admissível ou em qualquer caso, o reductor se encontrasse a trabalhar num ambiente de dimensões reduzidas ou com recirculação limitada do ar, é aconselhável usar um sistema auxiliar de arrefecimento com recirculação do óleo.

3.18 Carga radial em entrada/saída **$F_{r,1}, F_{r,2}$**

Em correspondência das entradas rápidas de tipo ligeiro, médio e pesado e dos suportes de saída MS, MC, ZI estão indicadas as curvas da carga radial admissível $F_{r,1}$ ou $F_{r,2}$ em função da abscissa x (distância de uma referência oportuna). O valor de carga radial admissível é referido a uma duração dos rolamentos, calculada segundo a norma ISO 281, equivalente, respetivamente, a:

- $10^7 n_1 \cdot h$ para os veios de entrada;
- $10^5 n_2 \cdot h$ para os veios de saída

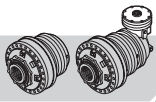

Per valori differenti dei fattori di durata è necessario introdurre un coefficiente correttivo $k_{r,1}$ o $k_{r,2}$ che si ricava da un'ulteriore curva, riportata in prossimità di quella relativa al carico radiale.

For different duration factor values a corrective coefficient $k_{r,1}$ or $k_{r,2}$ has to be used, found in another curve in proximity of the one relative to the radial load.

Für andere Zeitfaktoren muss ein Korrekturfaktor $k_{r,1}$ oder $k_{r,2}$ eingeführt werden, der einer weiteren Kurve entnommen werden kann, die neben der Kurve der Querlast abgetragen ist.



Per i supporti uscita con albero femmina scanalato o maschio cavo, le curve del carico radiale ammissibile non sono volutamente riportate, in quanto tali supporti non sono generalmente idonei a sopportare carichi radiali; tuttavia per applicazioni che prevedono la presenza di carichi radiali, è possibile valutare l'idoneità di tali supporti uscita e la durata dei cuscinetti contattando il Servizio Tecnico Reggiana Riduttori.

For the output supports with a female splined or male hollow shaft, the curves of the permitted radial load are not given on purpose as they are usually unsuitable for supporting radial loads; however, for applications where radial loads are foreseen, the suitability of such output supports and bearing life can be evaluated, contacting the Reggiana Riduttori Technical Service.

Für Lager am Ausgang mit Keilnutensteckwelle oder Hohlsteckwelle wurden auf die Kurven der zulässigen Querlast verzichtet, da diese Lager in der Regel nicht für die Belastung durch Querlasten geeignet sind. Bei Anwendungen, die das Anliegen von Querlasten vorsehen, kann zusammen mit dem Technischen Kundendienst von Reggiana Riduttori die Eignung dieser Lager am Ausgang und die Lebensdauer der Lager geprüft werden.

3.19 Carico assiale in uscita

$F_{a,2}$

Su tutte le tipologie di supporto uscita è ammessa la presenza di un carico assiale in verso entrante o uscente, purché questo sia applicato in maniera non eccentrica rispetto all'albero uscita.

3.19 Output axial load

$F_{a,2}$

An axial load, incoming or outgoing, is allowed on all types of output support provided it is not applied eccentrically in relation to the output shaft.

3.19 Achslast am Ausgang

$F_{a,2}$

Bei Anliegen von Achslast am Lager am Ausgang ist das Anliegen einer Achslast in eingehende oder ausgehende Richtung zulässig, vorausgesetzt, die Last liegt nicht außermittig bezogen auf die Ausgangswelle anliegt.



In presenza di carico assiale sul supporto uscita, o contemporaneamente di carico radiale e assiale, verificare l'idoneità del riduttore contattando il Servizio Tecnico Reggiana Riduttori.

When there is an axial load or an axial and radial load on the output support, verify the suitability of the reduction gear contacting the Reggiana Riduttori Technical Service.

Wenn es eine axiale Belastung oder eine axiale und radiale Belastung der Ausgang-Unterstützung, Verifizieren der Eignung des Untersetzungsgetriebe Kontaktaufnahme mit dem Reggiana Riduttori Technical Service.

3.20 Condizioni ambientali e limiti di impiego e funzionamento

La temperatura ambiente raccomandata per i riduttori epicicloidali Reggiana Riduttori è compresa nell'intervallo $-20^{\circ}\text{C}/+40^{\circ}\text{C}$.

Condizioni differenti di impiego sono, tuttavia, possibili, utilizzando particolari accorgimenti progettuali da concordare in modo specifico insieme al Servizio Tecnico Reggiana Riduttori.

Non è consentito il funzionamento al di sopra della temperatura massima ambiente di $+40^{\circ}\text{C}$ a meno di non operare a potenze inferiori alla potenza termica ammessa e dopo un opportuno test di funzionamento.

3.20 Environmental conditions and use/operating limits

The ambient temperature recommended for Reggiana Riduttori reduction gears ranges between -20°C and $+40^{\circ}\text{C}$.

Different conditions of use are however possible, taking certain designing measures which have to be agreed specifically with the Reggiana Riduttori technical service.

Operation is forbidden above the maximum ambient temperature of 40°C unless you are working at powers below the permitted thermal power and after conducting suitable operating tests.

3.20 Bedingungen am Standort und Einschränkungen für den Gebrauch

Die empfohlene Umgebungstemperatur bei Gebrauch der Planetengetriebe von Reggiana Riduttori liegt zwischen -20°C und $+40^{\circ}\text{C}$.

Bei abweichenden Bedingungen müssen die Planetengetriebe entsprechend verändert werden nach ausdrücklicher Absprache mit dem Technischen Kundendienst von Reggiana Riduttori.

Ein Betrieb bei einer Umgebungstemperatur von über $+40^{\circ}\text{C}$ ist nicht zulässig, es sei denn mit Leistungen unterhalb der zulässigen Wärmeleistung und nach einem Funktionstest.

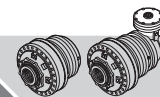

Pour des valeurs différentes des facteurs de durée, il faut entrer un coefficient correctif $k_{r,1}$ ou $k_{r,2}$ qu'on obtient à partir d'une autre courbe, se trouvant à proximité de la courbe relative à la charge radiale.

Para valores distintos de los factores de duración es necesario introducir un coeficiente de corrección $k_{r,1}$ o $k_{r,2}$ que se saca de una ulterior curva, presentada al lado de aquella referente a la carga radial.

No caso de valores diferentes dos fatores de duração é necessário introduzir um coeficiente corretivo $k_{r,1}$ ou $k_{r,2}$ que se obtém de uma sucessiva curva, indicada próxima daquela relativa à carga radial.



Pour les supports de sortie avec un arbre femelle cannelé ou mâle creux, les courbes de la charge radiale admissible ne sont pas, intentionnellement, indiquées, car ces supports ne sont généralement pas faits pour soutenir des charges radiales; pour des applications prévoyant la présence de charges radiales, il est toutefois possible d'estimer le bon choix de ces supports de sortie et la durabilité des roulements en contactant le service technique Reggiana Riduttori.

Para los soportes de salida con eje hembra acanalado o macho hueco, las curvas de la carga radial admitida han sido expresamente omitidas, ya que dichos soportes en general no son idóneos para soportar cargas radiales; de todas maneras, para aplicaciones que prevén la presencia de cargas radiales, es posible evaluar la idoneidad de dichos soportes de salida y la duración de los cojinetes contactando con el Servicio Técnico de Reggiana Riduttori.

No caso de suportes de saída com veio fêmea com ranhuras ou macho oco, as curvas da carga radial admissível não foram indicadas, dado que geralmente tais suportes não são idóneos a suportar cargas radiais; contudo para aplicações que prevêem a presença de cargas radiais, é possível avaliar a idoneidade de tais suportes de saída e a duração dos rolamentos contactando o Serviço Técnico Reggiana Riduttori.

3.19 Charge axiale à la sortie

$F_{a,2}$

Sur toutes les typologies de support de sortie, la présence d'une charge axiale vers l'entrée ou vers la sortie est admise, à condition qu'elle soit appliquée de manière non excentrique par rapport à l'arbre de sortie.

3.19 Carga axial en salida

$F_{a,2}$

En todos los tipos de soporte de salida se admite la presencia de una carga axial en dirección entrante o saliente, siempre que dicha carga sea aplicada de manera no excéntrica con respecto al eje de salida.

3.19 Carga axial em saída

$F_{a,2}$

Em todos os tipos de suporte de saída admitida a presença de uma carga axial no sentido de entrada ou saída, desde que o mesmo seja aplicado de modo não excêntrico respeito ao veio de saída.



En présence de charge axiale ou charge radiale et axiale sur le support de sortie, vérifier le bon choix du réducteur en contactant le service technique Reggiana Riduttori.

En presencia de carga axial o carga radial y axial sobre el soporte de salida, cabe comprobar la idoneidad del reductor contactando con el Servicio Técnico de Reggiana Riduttori.

Na presença de carga axial ou carga radial e axial no suporte saída, verificar a idoneidade do redutor contactando o Serviço Técnico Reggiana Riduttori.

3.20 Conditions ambiantes et limites d'utilisation et de fonctionnement

La température ambiante recommandée pour les réducteurs épicycloïdaux Reggiana Riduttori est comprise entre $-20^{\circ}\text{C}/+40^{\circ}\text{C}$.

Des conditions d'utilisation différentes sont toutefois possibles, en ayant recours à des mesures conceptuelles particulières à décider en accord avec le service technique Reggiana Riduttori.

Le fonctionnement au-delà de la température ambiante maximum de 40°C n'est pas autorisé, à moins que le fonctionnement ne soit pas à des puissances inférieures à la puissance thermique admise et après un test de fonctionnement spécial.

3.20 Condiciones ambientales y límites de utilización y funcionamiento

La temperatura ambiente recomendada para los reductores epicicloidales Reggiana Riduttori es entre -20°C y $+40^{\circ}\text{C}$.

Condiciones de utilización distintas son, de todas maneras, posibles, utilizando especiales soluciones de proyecto a concertar de manera específica con el Servicio técnico Reggiana Riduttori.

No se permite el funcionamiento por encima de la temperatura ambiente máxima de 40°C salvo que se trabaje con potencias menores que la potencia térmica admitida y después de efectuar un oportuno test de funcionamiento.

3.20 Condições ambientais e limites de emprego e funcionamento

A temperatura ambiente recomendada para os redutores epicicloidais Reggiana Riduttori é compreendida no intervalo $-20^{\circ}\text{C}/+40^{\circ}\text{C}$.

Condições diferentes de emprego são, contudo, possíveis, recorrendo a algumas soluções durante a fase de projeto e a concordar de modo específico juntamente com Serviço Técnico Reggiana Riduttori.

Não é consentido o funcionamento acima da temperatura máxima ambiente de 40°C a não ser que se trabalhe com potências inferiores à potência térmica admitida e depois de um oportuno teste de funcionamento.

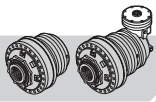
**4 SELEZIONE DEI RIDUTTORI**

Per la selezione del riduttore idoneo per una data applicazione è necessario conoscere:

- la velocità in entrata n_1 [min^{-1}];
- la velocità in uscita richiesta n_{2r} [min^{-1}];
- la coppia in uscita richiesta T_{2r} [Nm];
- la durata richiesta h_r [h];
- il fattore di servizio f_s , calcolato in base al tipo di applicazione e alle condizioni di utilizzo.

A partire da questi dati si determinano, quindi, il rapporto di riduzione richiesto:

4 SELECTING THE REDUCTION GEARS

To choose the reduction gear most suited for a given application it is necessary to know:

- input speed n_1 [min^{-1}];
- required output speed n_{2r} [min^{-1}];
- required output torque T_{2r} [Nm];
- the duration required h_r [h];
- the service factor f_s , calculated on the basis of the type of application and conditions of use.

With these data we can determine the reduction ratio required:

4 AUSWAHL VOM PLANETENGETRIEBE

Um das Planetengetriebe auszuwählen, das für die geplante Anwendung am besten geeignet ist, müssen folgende Werte bekannt sein:

- die Geschwindigkeit am Eingang n_1 [min^{-1}];
- die verlangte Geschwindigkeit am Ausgang n_{2r} [min^{-1}];
- das verlangte Drehmoment am Ausgang T_{2r} [Nm];
- die verlangte Dauer h_r [h];
- der Betriebsfaktor f_s , berechnet anhand der Art der Anwendung und den Bedingungen am Standort.

Aus diesen Werten wird das erforderliche Untersetzungsverhältnis:

$$i_r = \frac{n_1}{n_{2r}}$$

la coppia in uscita corretta:

the corrected output torque:

das korrigierte Drehmoment am Ausgang:

$$T_{2c} = T_{2r} \cdot f_s$$

e il fattore di durata:

and the duration factor:

und der Zeitfaktor berechnet:

$$f_{h,2} = n_{2r} \cdot h_r$$

Dalla tabella delle coppie nominali scegliere una grandezza di riduttore che abbia coppia nominale maggiore della T_{2c} . Quindi dalla tabella dei dati tecnici, posta all'inizio della sezione relativa alla grandezza individuata, selezionare un riduttore che abbia rapporto di riduzione i prossimo a quello richiesto i_r , assicurandosi che la coppia applicabile in uscita T_2 sia maggiore della T_{2c} in corrispondenza della colonna relativa ad un valore di n_{2xh} maggiore o uguale al fattore di durata $f_{h,2}$ calcolato.

Choose a reduction gear size from the nominal torque table that has a nominal torque greater than T_{2c} . Then, from the technical data table (at the beginning of the section of the size wanted) select a reduction gear with a reduction ratio i near to what is wanted i_r , making sure that the transmissible output torque T_2 is greater than T_{2c} by the column relative to a value of n_{2xh} greater or the same as the duration factor $f_{h,2}$ calculated.

Aus der Tabelle mit den Nenndrehmomenten eine Größe vom Planetengetriebe auswählen, deren Nenndrehmoment größer ist als T_{2c} .

Dann aus der Tabelle mit den technischen Daten, die sich am Anfang vom Abschnitt der ermittelten Größe befindet, das Planetengetriebe auswählen, dessen Untersetzungsverhältnis i etwa dem verlangten Untersetzungsverhältnis i_r entspricht und dabei sicherstellen, dass das am Ausgang anlegbare Drehmoment T_2 größer ist als der Wert T_{2c} , und zwar in der Spalte vom Wert n_{2xh} , der größer als oder gleichgroß wie der berechnete Zeitfaktor $f_{h,2}$ ist.

Esempio

Si vuole scegliere un riduttore lineare che funzioni alle seguenti condizioni:

- velocità in entrata $n_1 = 1500 \text{ min}^{-1}$
- velocità in uscita richiesta $n_{2r} = 15 \text{ min}^{-1}$
- coppia in uscita richiesta $T_{2r} = 15000 \text{ Nm}$
- durata richiesta $h_r = 5000 \text{ h}$
- fattore di servizio $f_s = 1.3$

Example

You want to choose a linear reduction gear that works at the following conditions:

- input speed $n_1 = 1500 \text{ min}^{-1}$
- required output speed $n_{2r} = 15 \text{ min}^{-1}$
- required output torque $T_{2r} = 15000 \text{ Nm}$
- the duration required $h_r = 5000 \text{ h}$
- service factor $f_s = 1.3$

Beispiel

Es soll ein lineares Planetengetriebe ausgewählt werden, das unter folgenden Bedingungen zum Einsatz kommt:

- Geschwindigkeit am Eingang $n_1 = 1500 \text{ min}^{-1}$
- verlangte Geschwindigkeit am Ausgang $n_{2r} = 15 \text{ min}^{-1}$
- verlangtes Drehmoment am Ausgang $T_{2r} = 15000 \text{ Nm}$
- verlangte Dauer $h_r = 5000 \text{ h}$
- Betriebsfaktor $f_s = 1.3$



4 SELECTION DES REDUCTEURS

Pour choisir le réducteur qui convient à une application donnée, il faut connaître:

- la vitesse à l'entrée n_1 [min^{-1}];
- la vitesse à la sortie exigée n_{2r} [min^{-1}];
- le couple à la sortie exigé T_{2r} [Nm];
- la durée exigée h_r [h];
- le facteur de service f_s , calculé en fonction du type d'application et des conditions d'utilisation.

A partir de ces données, on détermine le rapport de réduction demandé:

4 SELECCIÓN DE LOS REDUCTORES

Para seleccionar el reductor idóneo para una determinada aplicación es necesario conocer:

- la velocidad en entrada n_1 [min^{-1}];
- la velocidad en salida requerida n_{2r} [min^{-1}];
- el par en salida requerido T_{2r} [Nm];
- la duración requerida h_r [h];
- el factor de servicio f_s , calculado según el tipo de aplicación y las condiciones de uso.

A partir de estos datos se determinan, seguidamente, la relación de reducción requerida:

4 SELEÇÃO DOS REDUTORES

Para a seleção do redutor idóneo para uma dada aplicação é necessário conhecer:

- a velocidade em entrada n_1 [min^{-1}];
- a velocidade em saída necessária n_{2r} [min^{-1}];
- o par em saída necessário T_{2r} [Nm];
- a duração necessária h_r [h];
- de serviço f_s , calculado com base no tipo de aplicação e às condições de emprego.

A partir destes dados determina-se, a relação de redução necessária:

$$i_r = \frac{n_1}{n_{2r}}$$

le couple à la sortie corrigé:

el par en salida corregido:

o par em saída corrigido:

$$T_{2c} = T_{2r} \cdot f_s$$

et le facteur de durée:

y el factor de duración:

e o fator de duração:

$$f_{h,2} = n_{2r} \cdot h_r$$

A partir du tableau des couples nominaux, choisir une grandeur de réducteur ayant un couple nominal supérieur au T_{2c} .

Puis à partir du tableau des caractéristiques techniques, se trouvant au début de la section relative à la grandeur indiquée, choisir un réducteur ayant un rapport de réduction i proche du rapport demandé i_r tout en veillant à ce que le couple applicable à la sortie T_2 soit supérieur au T_{2c} dans la colonne relative à une valeur de $n_2 \times h$ supérieure ou égale au facteur de durée $f_{h,2}$ calculé.

En la tabla de los pares nominales se debe seleccionar una talla de reductor que tenga par nominal mayor que T_{2c} .

Luego, en la tabla de los datos técnicos, presentada al inicio de la sección referente a la talla individuada, se selecciona un reductor que tenga una relación de reducción i próxima a la requerida i_r , comprobando que el par aplicable en salida T_2 sea mayor que T_{2c} en correspondencia con la columna referente a un valor de $n_2 \times h$ mayor o igual que el factor de duración $f_{h,2}$ calculado.

Na tabela dos pares nominais escolher uma grandeza de redutor que tenha par nominal maior do que T_{2c} .

A seguir, da tabela dos dados técnicos, que se encontra no início da seção relativa à grandeza identificada, seleccionar um redutor que tenha relação de redução i próximo àquele necessário i_r , verificando que o par aplicável em saída T_2 seja maior do que T_{2c} em correspondência da coluna relativa a um valor de $n_2 \times h$ maior ou igual ao fator de duração $f_{h,2}$ calculado.

Exemple

Pour choisir un réducteur linéaire pouvant fonctionner aux conditions suivantes:

- vitesse à l'entrée $n_1 = 1500 \text{ min}^{-1}$
- vitesse à la sortie exigée $n_{2r} = 15 \text{ min}^{-1}$
- couple à la sortie exigé $T_{2r} = 15000 \text{ Nm}$
- durée exigée $h_r = 5000 \text{ h}$
- facteur de service $f_s = 1.3$

Ejemplo

Se desea seleccionar un reductor lineal que funcione en las siguientes condiciones:

- velocidad en entrada $n_1 = 1500 \text{ min}^{-1}$
- velocidad en salida requerida $n_{2r} = 15 \text{ min}^{-1}$
- par en salida requerido $T_{2r} = 15000 \text{ Nm}$
- duración requerida $h_r = 5000 \text{ h}$
- factor de servicio $f_s = 1.3$

Exemplo

Deseja-se escolher um redutor linear que funcione às seguintes condições:

- velocidade em entrada $n_1 = 1500 \text{ min}^{-1}$
- velocidade em saída necessária $n_{2r} = 15 \text{ min}^{-1}$
- par em saída necessário $T_{2r} = 15000 \text{ Nm}$
- duração necessária $h_r = 5000 \text{ h}$
- o fator de serviço $f_s = 1.3$

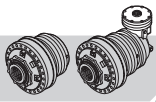

Il rapporto di riduzione richiesto vale:

The reduction ratio required is worth:

Das erforderliche Untersetzungsverhältnis beträgt:

$$i_r = \frac{n_1}{n_{2r}} = \frac{1500}{15} = 100;$$

la coppia corretta è invece:

while the corrected torque is:

Das korrigierte Drehmoment ist:

$$T_{2c} = T_{2r} \cdot f_s = 15000 \cdot 1.3 = 19500 \text{ Nm}$$

mentre il fattore di durata risulta pari a:

and the duration factor is equivalent to:

Der Zeitfaktor entspricht:

$$f_{h,2} = n_{2r} \cdot h_r = 15 \cdot 5000 = 75000$$

Dalla tabella delle coppie nominali si seleziona una grandezza di riduttore che abbia valore di coppia nominale T_{2n} maggiore della T_{2c} ; in questo caso la grandezza idonea è **RR2500**.

From the nominal torque table select a reduction gear size which has a nominal torque value T_{2n} greater than T_{2c} ; in this case the suitable size is **RR2500**.

Aus der Tabelle mit den Nenndrehmomenten wird eine Größe vom Planetengetriebe ausgewählt, deren Nenndrehmoment T_{2n} größer ist als T_{2c} . In diesem Fall ist die geeignete Größe **RR2500**.

Nella tabella delle prestazioni dei riduttori grandezza RR2500 è presente un riduttore lineare triplo stadio (L3) con rapporto 99.86, prossimo a quello richiesto; in corrispondenza della colonna relativa a

In the technical data table of the RR2500 size, there is a triple stage linear reduction gear (L3) with a 99.86 ratio, close to what is required; in the column relative to

In der Tabelle mit den Leistungen der Planetengetriebe der Größe RR2500 gibt es ein lineares dreistufiges (L3) Planetengetriebe mit einem Untersetzungsverhältnis von 99.86, das in etwa dem verlangten Untersetzungsverhältnis entspricht. In der Spalte vom Wert $n_2 \cdot h = 100000 > f_{h,2}$ kann der Wert vom anlegbaren Drehmoment T_2 abgelesen werden, der 20480 Nm entspricht.

$$n_2 \cdot h = 100000 > f_{h,2}$$

$$n_2 \cdot h = 100000 > f_{h,2}$$

si legge il valore della coppia applicabile T_2 che è pari a 20480 Nm.

you can read the value of the applicable torque T_2 which is 20480 Nm.

i	T_2 [Nm]						n_{1max} [min ⁻¹]	T_{2max} [Nm]	P_t [kW]	
	$n_2 \times h$									
1/...	10000 (10 ⁴)	25000 (2.5 · 10 ⁴)	50000 (5 · 10 ⁴)	100000 (10 ⁵)	500000 (5 · 10 ⁵)	1000000 (10 ⁶)				
RR2500 L1	4.00	29900	27820	25110	23000	19520	15860	2000	37000	38
	4.71	26350	23210	20210	19060	17270	15560	2000	37000	38
	5.85	20100	16730	14870	14250	12910	12370	2000	37000	38
RR2500 L2	15.69	29900	27820	25110	23000	18460	15000	3000	37000	23
	17.22	29900	27820	25110	23000	18200	14780	3000	37000	23
	21.88	24540	21800	20890	20030	17710	14380	3000	37000	23
	25.74	26350	23210	20210	19060	17270	15560	3000	37000	23
	30.25	20480	19130	18330	17570	15920	15260	3000	37000	23
	37.58	20100	16730	14870	14250	12910	12370	3000	37000	23
	46.24	16280	15390	14750	14140	12810	12280	3000	37000	23
	50.28	16300	15400	14750	14130	12800	12260	3000	37000	23
RR2500 L3	53.35	29900	27820	25110	23000	18460	15000	3500	37000	17
	62.77	29900	27820	25110	23000	18460	15000	3500	37000	17
	68.87	29900	27820	25110	23000	18200	14780	3500	37000	17
	86.09	26640	25180	24130	23000	18200	14780	3500	37000	17
	99.86	23560	22280	21360	20480	18200	14780	3500	37000	17
	109.41	24540	21800	20890	20030	17710	14380	3500	37000	17
	126.92	24540	21800	20890	20030	17710	14380	3500	37000	17
	149.31	26350	23210	20210	19060	17270	15560	3500	37000	17
	180.21	24520	23190	20210	19060	17270	15560	3500	37000	17
	211.76	20480	19130	18330	17570	15920	15260	3500	37000	17
	263.08	20100	16730	14870	14250	12910	12370	3500	37000	17
	323.66	16280	15390	14750	14140	12810	12280	3500	37000	17
	351.94	16300	15400	14750	14130	12800	12260	3500	37000	17
	RR2500 L4	245.62	29900	27820	25110	23000	18460	15000	3500	37000
289.25		29900	27820	25110	23000	17850	14500	3500	37000	13
340.30		29900	27820	25110	23000	18200	14780	3500	37000	13
398.46		29900	27820	25110	23000	18200	14780	3500	37000	13

Poiché questo valore è maggiore della coppia T_{2c} il riduttore selezionato è idoneo per lavorare alle condizioni richieste.

Since this value is greater than torque T_{2c} the reduction gear selected is suitable for working at the conditions required.

Da dieser Wert größer ist als das Drehmoment T_{2c} , eignet sich das ausgewählte Planetengetriebe für den Einsatz unter den verlangten Bedingungen.



Le rapport de réduction demandé vaut:

La relación de reducción requerida vale:

A relação de redução necessária vale

$$i_r = \frac{n_1}{n_{2r}} = \frac{1500}{15} = 100;$$

le couple corrigé est au contraire:

El par corregido es:

por sua vez, o par corrigido é:

$$T_{2c} = T_{2r} \cdot f_s = 15000 \cdot 1.3 = 19500 \text{ Nm}$$

alors que le facteur de durée est égal:

mientras que el factor de duración resulta igual que:

enquanto que o fator de duração resulta equivalente a:

$$f_{h,2} = n_{2r} \cdot h_r = 15 \cdot 5000 = 75000$$

A partir du tableau des couples nominaux, on choisit une grandeur de réducteur ayant une valeur de couple nominal T_{2n} supérieure à T_{2c} ; dans ce cas, la grandeur appropriée est **RR2500**.

En la tabla de los pares nominales se selecciona una talla de reductor que tenga valor de par nominal T_{2n} mayor que T_{2c} ; en este caso la talla idónea es **RR2500**.

Na tabela dos pares nominais selecciona-se uma grandezza de reductor que tenha valor de par nominal T_{2n} maior de T_{2c} ; neste caso a grandezza idónea é **RR2500**.

Sur le tableau des performances des réducteurs grandeur RR2500 se trouve un réducteur linéaire à trois étages (L3) avec un rapport de 99.86, proche du rapport demandé; en face de la colonne relative à

En la tabla de las prestaciones de los reductores de talla RR2500 hay un reductor lineal de triple etapa (L3) con relación 99.86, próxima a la requerida; en correspondencia con la columna referente a

Na tabela das prestações dos reductores grandezza RR2500 é presente um reductor linear triplo estágio (L3) com relação 99.86, próximo àquele necessário; em correspondência da coluna relativa a

$$n_2 \cdot h = 100000 > f_{h,2}$$

$$n_2 \cdot h = 100000 > f_{h,2}$$

$$n_2 \cdot h = 100000 > f_{h,2}$$

on peut lire la valeur du couple applicable T_2 de 20480 Nm.

leemos el valor del par aplicable T_2 que es igual que 20480 Nm.

lê-se o valor do par aplicável T_2 que é igual a 20480 Nm

i	T_2 [Nm]						n_{1max} [min ⁻¹]	T_{2max} [Nm]	P_t [kW]	
	$n_2 \times h$									
1/...	10000 (10 ⁴)	25000 (2.5 · 10 ⁴)	50000 (5 · 10 ⁴)	100000 (10 ⁵)	500000 (5 · 10 ⁵)	1000000 (10 ⁶)				
RR2500 L1	4.00	29900	27820	25110	23000	19520	15860	2000	37000	38
	4.71	26350	23210	20210	19060	17270	15560	2000	37000	38
	5.85	20100	16730	14870	14250	12910	12370	2000	37000	38
RR2500 L2	15.69	29900	27820	25110	23000	18460	15000	3000	37000	23
	17.22	29900	27820	25110	23000	18200	14780	3000	37000	23
	21.88	24540	21800	20890	20030	17710	14380	3000	37000	23
	25.74	26350	23210	20210	19060	17270	15560	3000	37000	23
	30.25	20480	19130	18330	17570	15920	15260	3000	37000	23
	37.58	20100	16730	14870	14250	12910	12370	3000	37000	23
	46.24	16280	15390	14750	14140	12810	12280	3000	37000	23
	50.28	16300	15400	14750	14130	12800	12260	3000	37000	23
RR2500 L3	53.35	29900	27820	25110	23000	18460	15000	3500	37000	17
	62.77	29900	27820	25110	23000	18460	15000	3500	37000	17
	68.87	29900	27820	25110	23000	18200	14780	3500	37000	17
	86.09	26640	25180	24130	23000	18200	14780	3500	37000	17
	99.86	23560	22280	21360	20480	18200	14780	3500	37000	17
	109.41	24540	21800	20890	20030	17710	14380	3500	37000	17
	126.92	24540	21800	20890	20030	17710	14380	3500	37000	17
	149.31	26350	23210	20210	19060	17270	15560	3500	37000	17
	180.21	24520	23190	20210	19060	17270	15560	3500	37000	17
	211.76	20480	19130	18330	17570	15920	15260	3500	37000	17
	263.08	20100	16730	14870	14250	12910	12370	3500	37000	17
	323.66	16280	15390	14750	14140	12810	12280	3500	37000	17
	351.94	16300	15400	14750	14130	12800	12260	3500	37000	17
RR2500 L4	245.62	29900	27820	25110	23000	18460	15000	3500	37000	13
	289.25	29900	27820	25110	23000	17850	14500	3500	37000	13
	340.30	29900	27820	25110	23000	18200	14780	3500	37000	13
	398.46	29900	27820	25110	23000	18200	14780	3500	37000	13

Cette valeur étant supérieure à la valeur du couple T_{2c} , le réducteur choisi est adapté à un travail dans les conditions requises.

Puesto que este valor es mayor que el par T_{2c} , el reductor seleccionado es idóneo para trabajar en las condiciones requeridas.

Considerando que este valor é maior do par T_{2c} o reductor seleccionado é idóneo para trabalhar às condições necessárias.

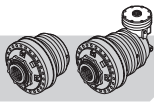

4.1 Funzionamento variabile

4.1 Variable operation

4.1 Variabler Betrieb

Nel caso in cui le condizioni di funzionamento sono variabili, ovvero il riduttore è soggetto ad un ciclo di lavoro con diversi livelli di coppia e/o velocità in uscita, è necessario calcolare la coppia in uscita richiesta equivalente, con la formula:

If operating conditions are variable, that is, the reduction gear is subject to a work cycle with different levels of torque and/or output speeds, you have to calculate the equivalent output torque required with the formula:

Bei variablen Betriebsbedingungen, d.h. dann, wenn das Planetengetriebe einem Arbeitszyklus mit unterschiedlichen Drehmomentstufen u/o Geschwindigkeiten am Ausgang unterliegt, muss das erforderliche äquivalente Drehmoment anhand folgender Formel berechnet werden:

$$T_{2r,eq} = \sqrt[6.7]{\frac{T_{2r,1}^{6.7} \cdot n_{2r,1} \cdot t_1\% + T_{2r,2}^{6.7} \cdot n_{2r,2} \cdot t_2\% + \dots + T_{2r,i}^{6.7} \cdot n_{2r,i} \cdot t_i\%}{n_{2r,1} \cdot t_1\% + n_{2r,2} \cdot t_2\% + \dots + n_{2r,i} \cdot t_i\%}}$$

e la velocità in uscita richiesta equivalente con la formula:

and the equivalent output speed with the formula:

und die erforderliche äquivalente Geschwindigkeit am Ausgang mit folgender Formel:

$$n_{2r,eq} = \frac{n_{2r,1} \cdot t_1\% + n_{2r,2} \cdot t_2\% + \dots + n_{2r,i} \cdot t_i\%}{100\%}$$

essendo $t_1, t_2 \dots t_i$ le percentuali di tempo (sul 100% del ciclo) in cui agiscono le coppie $T_{2r,1}, T_{2r,2} \dots T_{2r,i}$ alle velocità $n_{2r,1}, n_{2r,2} \dots n_{2r,i}$.
Una volta ottenuti i valori di coppia e velocità in uscita equivalenti è possibile procedere con la selezione del riduttore nel modo descritto in precedenza, moltiplicando, se necessario, la coppia in uscita equivalente per il fattore di servizio e calcolando il fattore di durata come prodotto della velocità equivalente per la durata totale richiesta.

*where $t_1, t_2 \dots t_i$ are the percentages of time (on 100% of the cycle) when the torques $T_{2r,1}, T_{2r,2} \dots T_{2r,i}$ act at the speed of $n_{2r,1}, n_{2r,2} \dots n_{2r,i}$.
Once you have the equivalent output speed and torque values, you can then proceed with selecting the reduction gear as described earlier, multiplying, if necessary, the equivalent output torque by the service factor and calculating the duration factor as the product of the equivalent speed by the total duration required.*

wobei $t_1, t_2 \dots t_i$ (auf 100% vom Zyklus) sind, in denen die Drehmomente $T_{2r,1}, T_{2r,2} \dots T_{2r,i}$ mit den Geschwindigkeiten $n_{2r,1}, n_{2r,2} \dots n_{2r,i}$ anliegen.
Nachdem die Werte vom äquivalenten Drehmoment und der äquivalenten Geschwindigkeit am Ausgang berechnet worden sind, kann das Planetengetriebe wie oben beschrieben ausgewählt werden, wobei das äquivalente Ausgangsdrehmoment ggf. mit dem Betriebsfaktor multipliziert und der Zeitfaktor als Produkt von äquivalenter Geschwindigkeit und insgesamt verlangter Dauer berechnet wird.

Esempio

Un riduttore è soggetto al seguente ciclo di lavoro:

Example

A reduction gear is subject to the following work cycle:

Beispiel

Ein Planetengetriebe ist folgendem Arbeitszyklus ausgesetzt:

Livello Level Stufe	t%	T _{2r}	n _{2r}
1	10	23000	10
2	25	16500	15
3	65	10000	25

La coppia in uscita richiesta equivalente risulta pari a:

The equivalent output torque required is equal to:

Das äquivalente Ausgangsdrehmoment entspricht:

$$T_{2r,eq} = \sqrt[6.7]{\frac{23000^{6.7} \cdot 10 \cdot 10\% + 16500^{6.7} \cdot 15 \cdot 25\% + 10000^{6.7} \cdot 25 \cdot 65\%}{10 \cdot 10\% + 15 \cdot 25\% + 25 \cdot 65\%}} = 15460 \text{ Nm}$$

mentre la velocità in uscita equivalente è:

while the equivalent output speed is equal to:

Die äquivalente Ausgangsgeschwindigkeit entspricht:

$$n_{2r,eq} = \frac{10 \cdot 10\% + 15 \cdot 25\% + 25 \cdot 65\%}{100\%} = 21 \text{ min}^{-1}$$

Da qui in poi si può procedere come visto nell'esempio precedente.

From this point on, you can proceed as for the previous example.

Von hier ab wird wie im oben beschriebenen Beispiel vorgegangen.

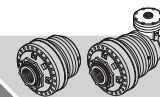

4.1 Fonctionnement variable

Si les conditions de fonctionnement sont variables, c'est-à-dire si le réducteur est sujet à un cycle de fonctionnement à plusieurs niveaux de couple et/ou de vitesse à la sortie, il est nécessaire de calculer le couple à la sortie exigé équivalent, en appliquant la formule suivante:

$$T_{2r,eq} = \sqrt[6.7]{\frac{T_{2r,1}^{6.7} \cdot n_{2r,1} \cdot t_1\% + T_{2r,2}^{6.7} \cdot n_{2r,2} \cdot t_2\% + \dots + T_{2r,i}^{6.7} \cdot n_{2r,i} \cdot t_i\%}{n_{2r,1} \cdot t_1\% + n_{2r,2} \cdot t_2\% + \dots + n_{2r,i} \cdot t_i\%}}$$

et la vitesse à la sortie exigée équivalente en employant la formule:

$$n_{2r,eq} = \frac{n_{2r,1} \cdot t_1\% + n_{2r,2} \cdot t_2\% + \dots + n_{2r,i} \cdot t_i\%}{100\%}$$

$t_1, t_2 \dots t_i$ étant les pourcentages de temps (sur 100 % du cycle) où les couples $T_{2r,1}, T_{2r,2} \dots T_{2r,i}$ agissent aux vitesses $n_{2r,1}, n_{2r,2} \dots n_{2r,i}$.

Après avoir obtenu les valeurs de couple et les vitesses à la sortie équivalentes, il est possible de procéder au choix du réducteur suivant les indications précédemment données, en multipliant, si besoin est, le couple à la sortie équivalent pour le facteur de service et en calculant le facteur de durée comme produit de la vitesse équivalente pour la durée totale exigée.

Exemple

Un réducteur est sujet au cycle de fonctionnement suivant:

Niveau Nivel Nivel	t%	T_{2r}	n_{2r}
1	10	23000	10
2	25	16500	15
3	65	10000	25

Le couple à la sortie exigé équivalent est égal à:

$$T_{2r,eq} = \sqrt[6.7]{\frac{23000^{6.7} \cdot 10 \cdot 10\% + 16500^{6.7} \cdot 15 \cdot 25\% + 10000^{6.7} \cdot 25 \cdot 65\%}{10 \cdot 10\% + 15 \cdot 25\% + 25 \cdot 65\%}} = 15460 \text{ Nm}$$

alors que la vitesse à la sortie équivalente est:

$$n_{2r,eq} = \frac{10 \cdot 10\% + 15 \cdot 25\% + 25 \cdot 65\%}{100\%} = 21 \text{ min}^{-1}$$

A partir de là, il est possible de procéder comme indiqué dans l'exemple précédent.

4.1 Funcionamiento variable

Si las condiciones de funcionamiento son variables, es decir que el reductor está sujeto a un ciclo de trabajo con distintos niveles de par y/o velocidad en salida, es necesario calcular el par en salida requerido equivalente, aplicando la fórmula:

y la velocidad en salida requerida equivalente con la fórmula:

Con $t_1, t_2 \dots t_i$ son los porcentajes de tiempo (sobre el 100% del ciclo) en los cuales actúan los pares $T_{2r,1}, T_{2r,2} \dots T_{2r,i}$ a las velocidades $n_{2r,1}, n_{2r,2} \dots n_{2r,i}$.

Una vez conseguidos los valores de par y velocidad en salida equivalentes, es posible proceder con la selección del reductor de la manera descrita anteriormente, multiplicando, si fuese necesario, el par en salida equivalente por el factor de servicio y calculando el factor de duración como producto de la velocidad equivalente por la duración total requerida.

Ejemplo

Un reductor está sujeto al siguiente ciclo de trabajo:

4.1 Funcionamento variável

No caso em que as condições de funcionamento sejam variáveis, ou o redutor seja sujeito a um ciclo de trabalho com diversos níveis de par e/ou velocidade em saída, é necessário calcular o par em saída necessário equivalente, com a fórmula:

e a velocidade em saída necessária equivalente com a fórmula:

sendo $t_1, t_2 \dots t_i$ as percentagens de tempo (sobre 100% do ciclo) em que agem ao pares $T_{2r,1}, T_{2r,2} \dots T_{2r,i}$ às velocidades $n_{2r,1}, n_{2r,2} \dots n_{2r,i}$.

Depois de termos obtido os valores de par e velocidade em saída equivalentes é possível proceder com a seleção do reductor no modo descrito precedentemente, multiplicando, se necessário, o par em saída equivalente para o fator de serviço e calculando o fator de duração como produto da velocidade equivalente pela duração total necessária.

Exemplo

Um redutor está sujeito ao seguinte ciclo de trabalho:

El par en salida requerido equivalente resulta ser:

O par em saída necessário equivalente resulta igual a:

mientras que la velocidad en salida equivalente es:

mentre a velocidade em saída equivalente é:

Desde aquí en adelante se puede proceder como visto en el ejemplo precedente.

Daqui para diante pode-se proceder como visto no exemplo precedente.

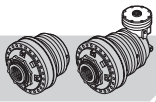

5 VERIFICHE

Una volta selezionato il riduttore in base ai parametri di funzionamento è opportuno procedere con le seguenti verifiche, per garantire la piena compatibilità del riduttore con l'applicazione.

5.1 Verifica della velocità massima in entrata

Il valore della velocità massima in entrata di ciascun riduttore, sia in configurazione lineare sia in configurazione angolare, è riportato nella apposita colonna della tabella dei dati tecnici. In caso di riduttore angolare si raccomanda di non oltrepassare i 1500 min^{-1} in funzionamento continuo, onde evitare un sensibile innalzamento del livello sonoro e un incremento della temperatura dovuta allo sbattimento dell'olio. Se è presente un'entrata veloce si consiglia di non superare i 1500 min^{-1} in condizioni di funzionamento continuo, per non causare notevoli incrementi della temperatura dell'olio. Nel caso di freni negativi si consiglia di non superare le seguenti velocità:

- **RF2** : 1500 min^{-1} ;
- **RF5** : 1000 min^{-1} ;
- **RF170÷290** : 750 min^{-1} .



In generale, quando le condizioni di carico prevedono lunghi periodi di funzionamento a velocità prossima a $n_{1\text{max}}$ o picchi con velocità superiore a $n_{1\text{max}}$, contattare il Servizio Tecnico Reggiana Riduttori.

5.2 Verifica della coppia massima

La coppia massima, cioè il livello di coppia ammesso durante l'avviamento o durante picchi occasionali, non deve mai superare il valore $T_{2\text{max}}$ riportato nella apposita colonna della tabella dei dati tecnici per il riduttore selezionato.

Quando le condizioni di carico prevedono frequenti avviamenti, inversioni del moto o lunghi periodi di funzionamento ad una coppia prossima a $T_{2\text{max}}$ è consigliabile selezionare un riduttore di grandezza superiore.



Nel caso di supporto uscita MS o MC ed in presenza di un carico radiale, la coppia massima applicabile subisce una diminuzione. In questi casi contattare il Servizio Tecnico Reggiana Riduttori per verificare l'idoneità del supporto uscita.

5 CHECKS

Once the reduction gear has been selected based on operating parameters, it is advisable to proceed with the following checks to guarantee complete compatibility of the reduction gear with the application.

5.1 Checking maximum input speed

The value of maximum input speed of each reduction gear, both in the linear and angular configuration, is given in the relative column of the technical data table. For angular reduction gears do not exceed 1500 min^{-1} in continuous operation to avoid a significant increase in the sound level and in the temperature due to oil splash. In the case of a fast input, we recommend not exceeding 1500 min^{-1} in continuous operating conditions so as not to overheat the oil. In the case of negative brakes, we recommend not to exceed the following speeds:

- **RF2** : 1500 min^{-1} ;
- **RF5** : 1000 min^{-1} ;
- **RF170÷290** : 750 min^{-1} .

In general, when load conditions entail long periods of operation at a speed close to $n_{1\text{max}}$ or peaks with speed higher than $n_{1\text{max}}$, contact the Reggiana Riduttori Technical Service.

5.2 Checking maximum torque

Maximum torque, that is, the level of torque permitted during start-up or occasional peaks, must never exceed $T_{2\text{max}}$ which is given in the relative column in the technical data table for the reduction gear selected.

When load conditions entail frequent start-ups, direction reversals or long periods of operation at a torque close to $T_{2\text{max}}$ it is advisable to select a bigger size reduction gear.

In the case of an MS or MC output support, and when there is a radial load, the maximum applicable torque must be reduced. In these cases contact the Reggiana Riduttori Technical Service to verify the suitability of the output support.

5 KONTROLLEN

Nachdem das Planetengetriebe anhand der Betriebsparameter ausgewählt worden ist, sollten folgende Kontrollen durchgeführt werden, um die volle Kompatibilität vom Planetengetriebe mit der Anwendung zu garantieren.

5.1 Kontrolle der maximalen Eingangsgeschwindigkeit

Der Wert der maximalen Eingangsgeschwindigkeit von jedem Planetengetriebe mit linearer Konfiguration oder mit Winkelkonfiguration ist in der entsprechenden Spalte der Tabelle mit den technischen Daten angegeben. Bei Planetengetrieben mit Winkelkonfiguration wird dazu geraten, den Wert von 1500 min^{-1} bei Dauerbetrieb nicht zu überschreiten, um ein deutliches Ansteigen vom Schallpegel und eine Zunahme der Temperatur durch das Schlagen vom Öl zu vermeiden. Wenn ein schneller Eingang vorhanden ist, wird dazu geraten, den Wert von 1500 min^{-1} bei Dauerbetrieb nicht zu übersteigen, da es sonst zu einem beachtlichen Anstieg der Öltemperatur kommen kann. Im Fall von Negativbremsen sollten folgende Geschwindigkeiten nicht übersteigen werden:

- **RF2** : 1500 min^{-1} ;
- **RF5** : 1000 min^{-1} ;
- **RF170÷290** : 750 min^{-1} .

Bei Belastungsbedingungen, die lange Betriebszeiten mit einer Geschwindigkeit von etwa $n_{1\text{max}}$ oder Spitzen mit einer Geschwindigkeit von $n_{1\text{max}}$ vorsehen, bitte Rücksprache mit dem Technischen Kundendienst von Reggiana Riduttori halten.

5.2 Kontrolle vom maximalen Drehmoment

Das maximale Drehmoment, d.h. das Drehmoment, das beim Anlaufen oder bei gelegentlichen Spitzen zugelassen ist, darf auf keinen Fall den Wert $T_{2\text{max}}$ übersteigen, der in der entsprechenden Spalte der Tabelle mit den technischen Daten vom ausgewählten Planetengetriebe angegeben ist.

Wenn die Belastungsbedingungen ein häufiges Starten, häufige Umkehrungen der Laufbewegung oder lange Betriebszeiten mit einem Drehmoment von $T_{2\text{max}}$ vorsehen, sollte ein größer ausgelegtes Planetengetriebe gewählt werden.

Bei Lagern MS oder MC am Ausgang und bei Anliegen einer Querlast verringert sich das maximal anlegbare Drehmoment. In diesem Fall bitte mit dem Technischen Kundendienst von Reggiana Riduttori Rücksprache Halten, um die Eignung vom Lager am Ausgang zu prüfen.

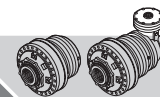

5 CONTROLES

Après avoir choisi le réducteur suivant les paramètres de fonctionnement, il convient de procéder aux contrôles suivants, pour s'assurer que le réducteur est parfaitement compatible avec l'application.

5.1 Contrôle de la vitesse maximum à l'entrée

La valeur de la vitesse maximum à l'entrée de chaque réducteur, aussi bien en configuration linéaire qu'en configuration angulaire, figure dans la colonne correspondante du tableau des caractéristiques techniques. En cas de réducteur angulaire, il est recommandé de ne pas dépasser 1500 min^{-1} en service continu, afin d'éviter une augmentation importante des nuisances sonores et une hausse de la température, due au barbotage de l'huile. Si une entrée rapide est présente, il est conseillé de ne pas dépasser 1500 min^{-1} dans des conditions de service continu, pour ne pas provoquer de hausses de la température de l'huile. En cas de freins négatifs, il est conseillé de ne pas dépasser les vitesses suivantes:

- **RF2** : 1500 min^{-1} ;
- **RF5** : 1000 min^{-1} ;
- **RF170÷290** : 750 min^{-1} .



En général, quand les conditions de charge prévoient de longues périodes de fonctionnement à une vitesse proche de $n_{1\text{max}}$ ou des pics à une vitesse supérieure à $n_{1\text{max}}$, contacter le service technique Reggiana Riduttori.

5.2 Contrôles du couple maximum

Le couple maximum, c'est-à-dire le niveau de couple admis au cours du démarrage ou au moment des pics occasionnels, ne doit jamais dépasser la valeur $T_{2\text{max}}$ figurant dans la colonne du tableau des caractéristiques techniques pour le réducteur choisi. Quand les conditions de charge prévoient des démarrages fréquents, des inversions du mouvement ou de longues périodes de fonctionnement à un couple proche de $T_{2\text{max}}$, il est conseillé de choisir un réducteur de grandeur supérieure.



Avec un support à la sortie MS ou MC et en présence d'une charge radiale, le couple maximum applicable subit une diminution. Dans ces cas, contacter le service technique Reggiana Riduttori pour vérifier l'adéquation du support à la sortie.

5 COMPROBACIONES

Una vez seleccionado el reductor sobre la base de los parámetros de funcionamiento, es oportuno proceder con las siguientes comprobaciones, para garantizar la plena compatibilidad del reductor con la aplicación.

5.1 Comprobación de la velocidad máxima en entrada

El valor de la velocidad máxima en entrada de cada reductor, tanto en configuración lineal como en configuración angular, se presenta en la correspondiente columna de la tabla de los datos técnicos. En caso de reductor angular, se recomienda no superar las 1500 min^{-1} en funcionamiento continuo, a fin de evitar un aumento notable del nivel sonoro y un aumento de la temperatura debido a la agitación del aceite. Si hay presente una entrada rápida, se aconseja no superar las 1500 min^{-1} en condiciones de funcionamiento continuo, para no causar notables aumentos de la temperatura del aceite. En el caso de frenos negativos, se aconseja no superar las siguientes velocidades .

- **RF2** : 1500 min^{-1} ;
- **RF5** : 1000 min^{-1} ;
- **RF170÷290** : 750 min^{-1} .

En general, cuando las condiciones de carga prevén largos periodos de funcionamiento a velocidad próxima a $n_{1\text{max}}$ o picos con velocidad mayor que $n_{1\text{max}}$, contactar con el Servicio Técnico de Reggiana Riduttori.

5.2 Comprobación del par máximo

El par máximo, es decir el nivel de par admitido durante el arranque o durante picos ocasionales, no debe superar nunca el valor $T_{2\text{max}}$ presentado en la correspondiente columna de la tabla de los datos técnicos para el reductor seleccionado.

Cuando las condiciones de carga prevén frecuentes arranques, inversiones de la marcha o largos periodos de funcionamiento con un par próximo a $T_{2\text{max}}$ se aconseja seleccionar un reductor de talla superior.

En el caso de soporte de salida MS ó MC y en presencia de una carga radial, el par máximo aplicable disminuye. En estos casos cabe contactar con el Servicio Técnico de Reggiana Riduttori para comprobar la idoneidad del soporte de salida.

5 VERIFICAÇÕES

Depois de termos seleccionado o reductor com base nos parâmetros de funcionamento é oportuno proceder com as seguintes verificações, para garantir a plena compatibilidade do reductor com a aplicação.

5.1 Verificação da velocidade máxima em entrada

O valor da velocidade máxima em entrada de cada reductor, seja em configuração linear seja em configuração angular, é indicado na respetiva coluna da tabela dos dados técnicos. No caso de reductor angular recomendamos de não ultrapassar os 1500 min^{-1} em funcionamento contínuo, para evitar um sensível aumento do nível sonoro e um incremento da temperatura devida ao batimento do óleo. Se se encontra presente uma entrada rápida aconselhamos não superar os 1500 min^{-1} em condições de funcionamento contínuo, para não provocar notáveis aumentos da temperatura do óleo. No caso de freios negativos aconselhamos não superar as seguintes velocidades:

- **RF2** : 1500 min^{-1} ;
- **RF5** : 1000 min^{-1} ;
- **RF170÷290** : 750 min^{-1} .

Em geral, quando as condições de carga prevêem longos períodos de funcionamento a velocidade próxima a $n_{1\text{max}}$ ou picos com velocidade superior a $n_{1\text{max}}$, contatar o Serviço Técnico Reggiana Riduttori.

5.2 Verificação do par máximo

O par máximo, ou seja o nível de par admitido durante o início de funcionamento ou durante picos ocasionais, nunca se deve superar o valor $T_{2\text{max}}$ indicado na respetiva coluna da tabela dos dados técnicos do reductor seleccionado.

Quando as condições de carga prevêem frequentes inícios de funcionamento, inversões do movimento ou longos períodos de funcionamento a um par próximo a $T_{2\text{max}}$ é aconselhável seleccionar um reductor de grandeza superior.

No caso de suporte saída MS ou MC e na presença de uma carga radial, o par máximo aplicável sofre uma diminuição. Nestes casos contatar o Serviço Técnico Reggiana Riduttori para verificar a idoneidade do suporte saída.

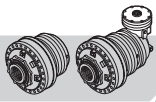

5.3 Verifica dei carichi radiali e assiali

Nel caso in cui sia presente un carico radiale sull'albero uscita occorre verificare che questo non sia superiore al valore massimo applicabile (funzione dell'ascissa x), per il fattore di durata richiesto.

Le curve dei carichi radiali sono riportate all'interno delle sezioni relative a ciascuna grandezza di riduttore, in base al tipo di supporto uscita.

Se il fattore di durata richiesto $f_{h,2}$ è diverso da 10^5 (valore in base al quale sono state ottenute le curve) occorre moltiplicare il carico massimo applicabile per un coefficiente correttivo $k_{r,2}$, che si ricava dalle apposite curve.

Qualora il carico radiale che si intende applicare risulti superiore a quello applicabile, occorre passare alla grandezza superiore di riduttore.

Volendo calcolare il fattore di durata conseguente all'applicazione di un carico radiale $F_{r,2}$ nella posizione x occorre calcolare $k_{r,2}$ come rapporto tra carico applicato e carico massimo applicabile in x (ricavato dalla curva relativa al supporto uscita considerato); entrando con questo valore sulla curva che fornisce $k_{r,2}$ in funzione del fattore di durata è possibile ricavare la durata del supporto uscita in termini di $n_2 \cdot h$.



Nel caso di presenza simultanea di carichi radiali e assiali occorre verificare l'idoneità del supporto uscita contattando il Servizio Tecnico Reggiana Riduttori.

Allo stesso modo se è presente un carico radiale in ingresso bisogna verificare che questo non sia superiore a quello massimo ammissibile riportato sulla curva corrispondente al tipo di entrata veloce applicata al riduttore. Anche in questo caso se il fattore di durata in ingresso $k_{r,1}$ è diverso da 10^7 (valore in base al quale sono state ottenute le curve) occorre correggere il valore ricavato dalla curva del carico radiale mediante il fattore $k_{r,1}$ che si ricava dalle apposite curve.

5.3 Checking radial and axial loads

If there is a radial load on the output shaft you need to verify that it is no higher than the maximum applicable value (abscissa x function) for the duration factor required.

The curves of the radial loads are given in the sections relative to each reduction gear size, based on the type of output support.

If the duration factor required $f_{h,2}$ is different from 10^5 (value on the basis of which the curves are obtained) you have to multiply the maximum applicable load by a corrective coefficient $k_{r,2}$, which is found by way of the relative curves.

If the radial load you intend applying is greater than the applicable load, you have to go to the next higher size reduction gear.

Wanting to calculate the duration factor consequential to the application of a radial load $F_{r,2}$ in position x , $k_{r,2}$ has to be calculated as the ratio between the applied load and the maximum applicable load in x (gleaned from the curve relative to the output support considered); entering with this value on the curve that provides $k_{r,2}$ as a function of the duration factor, it is possible to find the duration of the output support in terms of $n_2 \cdot h$.

If we have radial and axial loads simultaneously, it is necessary to verify the suitability of the output support contacting the Reggiana Riduttori Technical Service.

In the same way, if there is a radial load in input you have to verify that it is no higher than the maximum applicable one shown on the curve corresponding to the type of fast input applied to the reduction gear. Also in this case, if the duration factor in input $k_{r,1}$ is different from 10^7 (value on the basis of which the curves are obtained) it is necessary to correct the value gleaned from the radial load curve by means of factor $k_{r,1}$ which is gleaned from the relative curves.

5.3 Kontrolle von Querlasten und Achslasten

Sollte eine Querlast auf die Ausgangswelle einwirken, muss sichergestellt werden, dass die Querlast für den verlangten Zeitfaktor nicht den maximal anlegbaren Wert (Funktion der X-Koordinate) übersteigt.

Die Kurven der Querlasten sind in den Abschnitten der einzelnen Planetengetriebe-begrößen angegeben, je nach Ausgangslager.

Wenn ein anderer Zeitfaktor $f_{h,2}$ als 10^5 verlangt wird (Wert, anhand dessen die Kurven berechnet wurden), muss die maximal anlegbare Last mit einem Korrekturkoeffizienten $k_{r,2}$ multipliziert werden, der den entsprechenden Kurven entnommen werden kann.

Sollte die Querlast, die angelegt werden soll, größer sein als der Wert der maximal anlegbaren Querlast, muss ein größeres ausgelegtes Planetengetriebe. Wenn der Zeitfaktor für das Einwirken einer Querlast $F_{r,2}$ in Position x berechnet werden soll, muss $k_{r,2}$ als das Verhältnis von anliegender Last und maximal anlegbarer Last in Punkt x berechnet werden (welche der Kurve vom berücksichtigten Ausgangslager entnommen werden kann). Mit diesem Wert kann dann anhand der Kurve von $k_{r,2}$ in Abhängigkeit vom Zeitfaktor die Dauer vom Ausgangslager als $n_2 \cdot h$ abgeleitet werden.

Sollten gleichzeitig Querlasten und Achslasten anliegen, bitte Rücksprache mit dem Technischen Kundendienst von Reggiana Riduttori halten, um die Eignung vom Ausgangslager zu prüfen.

Die gleichen Überlegungen gelten für den Fall, dass am Eingang eine Querlast anliegt. Auch hier muss sichergestellt werden, dass diese nicht die maximal zulässige Last übersteigt, die der Kurve vom Typ der schnellen Eingangs entnommen werden kann, welcher am Planetengetriebe montiert ist. Wenn sich der Zeitfaktor am Eingang $k_{r,1}$ von 10^7 (Wert, anhand dessen die Kurven berechnet wurden) unterscheidet, muss auch in diesem Fall der Wert, der der Querlastkurve entnommen worden ist, mit dem Faktor $k_{r,1}$ korrigiert werden, der den entsprechenden Kurven entnommen werden kann.

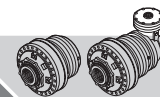

5.3 Contrôle des charges radiales et axiales

En présence d'une charge radiale sur l'arbre à la sortie, veiller à ce qu'elle ne soit pas supérieure à la valeur maximum applicable (fonction de l'abscisse x), pour le facteur de durée exigé.

Les courbes des charges radiales sont indiquées dans les sections relatives à chaque grandeur de réducteur, suivant le support à la sortie.

Si le facteur de durée exigé $f_{h,2}$ est différent de 10^5 (valeur en fonction de laquelle les courbes ont été obtenues) il faut multiplier la charge maximum applicable par un coefficient correctif $k_{r,2}$, qu'on prend des courbes correspondantes.

Si la charge radiale qu'on veut appliquer est supérieure à la charge applicable, il faut passer à la grandeur supérieure de réducteur.

Si l'on veut calculer le facteur de durée consécutif à l'application d'une charge radiale $F_{r,2}$ dans la position x , il faut calculer $k_{r,2}$ comme rapport entre charge appliquée et charge maximum applicable en x (pris de la courbe relative au support à la sortie pris en considération); en entrant avec cette valeur sur la courbe qui fournit $k_{r,2}$ en fonction du facteur de durée, il est possible de trouver la durée du support à la sortie en termes de $n_2 \cdot h$.



En cas de présence simultanée de charges radiales et axiales, vérifier l'adéquation du support à la sortie en contactant le service technique Reggiana Riduttori.

De la même manière, si une charge radiale est présente à l'entrée, il faut veiller à ce qu'elle ne dépasse la charge maximum admissible indiquée sur la courbe correspondant au type d'entrée rapide appliquée au réducteur. Dans ce cas également, si le facteur de durée à l'entrée $k_{r,1}$ est différent de 10^7 (valeur selon laquelle on a obtenu les courbes) il faut corriger la valeur trouvée à partir de la courbe de la charge radiale par l'intermédiaire du facteur $k_{r,1}$ qu'on obtient à partir des courbes correspondantes.

5.3 Comprobación de las cargas radiales y axiales

Si hay presente una carga radial sobre el eje de salida, cabe comprobar que no supere el valor máximo aplicable (función de la abscisa x), por el factor de duración requerido.

Las curvas de las cargas radiales se indican dentro de las secciones correspondientes a cada talla de reductor, según el tipo de soporte de salida.

Si el factor de duración requerido $f_{h,2}$ es distinto de 10^5 (valor sobre la base del cual se han obtenido las curvas) es necesario multiplicar la carga máxima aplicable por un coeficiente de corrección $k_{r,2}$, que se saca de las curvas correspondientes.

Si la carga radial que se desea aplicar resulta ser mayor que la aplicable, es necesario pasar a la talla superior de reductor.

Deseando calcular el factor de duración consiguiente a la aplicación de una carga radial $F_{r,2}$ en la posición x es necesario calcular $k_{r,2}$ como relación entre carga aplicada y carga máxima aplicable en x (sacado de la curva correspondiente al soporte de salida considerado); entrando con este valor en la curva que proporciona $k_{r,2}$ en función del factor de duración es posible sacar la duración del soporte de salida en términos de $n_2 \cdot h$.

En caso de presencia simultánea de cargas radiales y axiales, es necesario comprobar la idoneidad del soporte de salida contactando con el Servicio Técnico de Reggiana Riduttori.

De la misma manera, si hay presente una carga radial en entrada es necesario comprobar que ésta no supere la máxima admitida, indicada en la curva correspondiente al tipo de entrada rápida aplicada al reductor. También en este caso si el factor de duración en entrada $k_{r,1}$ es distinto de 10^7 (valor sobre la base del cual se han conseguido las curvas) es necesario corregir el valor sacado de la curva de la carga radial mediante el factor $k_{r,1}$ que se saca de las curvas correspondientes.

5.3 Verificação das cargas radiais e axiais

No caso em que se encontre presente uma carga radial no eixo de saída é necessário verificar que esta não seja superior ao valor máximo aplicável (função da abscissa x), para o fator de duração necessário.

As curvas das cargas radiais estão indicadas no interior das seções relativas a cada grandezza de reductor, segundo o tipo de suporte saída.

Se o fator de duração necessário $f_{h,2}$ é diverso de 10^5 (valor segundo o qual foram obtidas as curvas) é necessário multiplicar a carga máxima aplicável por um coeficiente corretivo $k_{r,2}$, que se obtém nas respetivas curvas.

No caso em que a carga radial que se deseja aplicar resulte superior àquela aplicável, é necessário passar à grandezza superior de reductor.

Desejando calcular o fator de duração conseqüente à aplicação de uma carga radial $F_{r,2}$ na posição x é necessário calcular $k_{r,2}$ como relação entre a carga aplicada e carga máxima aplicável em x (obtida na curva relativa ao suporte saída considerado); entrando com este valor na curva que fornece $k_{r,2}$ em função do fator de duração é possível obter a duração do suporte saída em termos de $n_2 \cdot h$.

No caso de presença simultânea de cargas radiais e axiais é necessário verificar a idoneidade do suporte saída contactando o Serviço Técnico Reggiana Riduttori.

Do mesmo modo, se se encontra presente uma carga radial em entrada é preciso verificar que a mesma não seja superior àquela máxima admissível indicada na curva correspondente ao tipo de entrada veloz aplicada ao reductor. Também neste caso se o fator de duração em entrada $k_{r,1}$ é diverso de 10^7 (valor segundo o qual foram obtidas as curvas) é necessário corrigir o valor obtido da curva da carga radial mediante o fator $k_{r,1}$ que se obtém nas respetivas curvas.

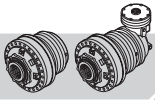

Esempio 1

Nota la posizione del carico radiale $x = 150\text{mm}$ e il fattore di durata richiesto $n_2 \cdot h = 500000$, si vuole conoscere il carico radiale $F_{r,2}$ applicabile sull'albero uscita del riduttore RR2500 MS.

Example 1

Knowing the position of the radial load $x=150\text{mm}$ and the duration factor required $n_2 \cdot h = 500000$, we want to know the radial load $F_{r,2}$ that can be applied on the output shaft of the RR2500 MS reduction gear.

Beispiel 1

Bei einer Position der Achslast $x=150\text{mm}$ und einem verlangten Zeitfaktor von $n_2 \cdot h = 500000$, soll die Querlast $F_{r,2}$ ermittelt werden, die an der Ausgangswelle vom Planetengetriebe RR2500 MS angelegt werden kann.

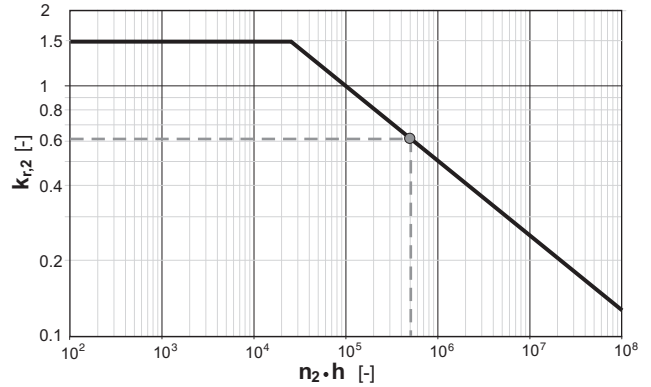
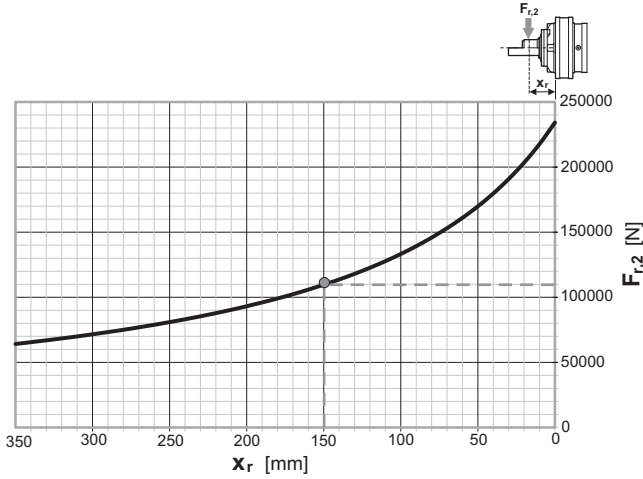

Dal grafico del carico radiale si ricava il valore nominale applicabile a 150mm, pari a 110000N. Questo valore deve essere corretto attraverso il fattore $k_{r,2}$ per tenere conto del fattore di durata diverso da 10^5 ; dal secondo grafico, in corrispondenza dell'ascissa $n_2 \cdot h = 500000$ si ricava il valore di $k_{r,2}$ cercato, pari a 0.62. Dunque il carico radiale massimo che è possibile applicare in posizione x è pari a:

In the radial load graph we can find the nominal applicable value at 150mm, equal to 110000N. This value has to be corrected by means of factor $k_{r,2}$ in order to take into account the duration factor different from 10^5 ; in the second graph, where the abscissa $n_2 \cdot h = 500000$ is, we can find the $k_{r,2}$ value we are looking for, equal to 0.62. So, the maximum radial load that can be applied in position x is equal to:

Aus der Querlastkurve wird der bei 150mm anlegbare Nennwert ermittelt, der 110000N entspricht. Dieser Wert muss mit dem Faktor $k_{r,2}$ korrigiert werden, um den von 10^5 abweichenden Zeitfaktor zu berücksichtigen. Aus der zweiten Kurve kann auf Höhe der X-Koordinate $n_2 \cdot h = 500000$ der gesuchte Wert $k_{r,2}$ entnommen werden, der 0.62 entspricht. In Position x kann also eine maximale Querlast mit folgendem Wert angelegt werden:

$$F_{r,2} = F_{r,2nom} \cdot k_{r,2} = 110000 \cdot 0.62 = 68200 \text{ N}$$

Esempio 2

Nota la posizione del carico radiale $x = 150 \text{ mm}$ ed il suo valore $F_{r,2} = 80000\text{N}$, si vuole determinare il fattore di durata del supporto uscita per il riduttore RR2500 MS.

Example 2

Knowing the position of the radial load $x=150\text{mm}$ and its $F_{r,2}=80000\text{N}$ value, we want to know the output support's duration factor for the RR2500 MS reduction gear.

Beispiel 2

Bei einer Position der Achslast $x=150\text{mm}$ und deren Wert $F_{r,2} = 80000\text{N}$ soll der Zeitfaktor vom Ausgangslager für das Planetengetriebe RR2500 MS ermittelt werden.

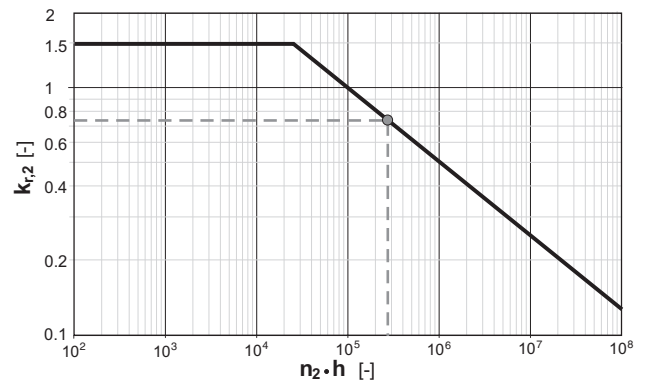
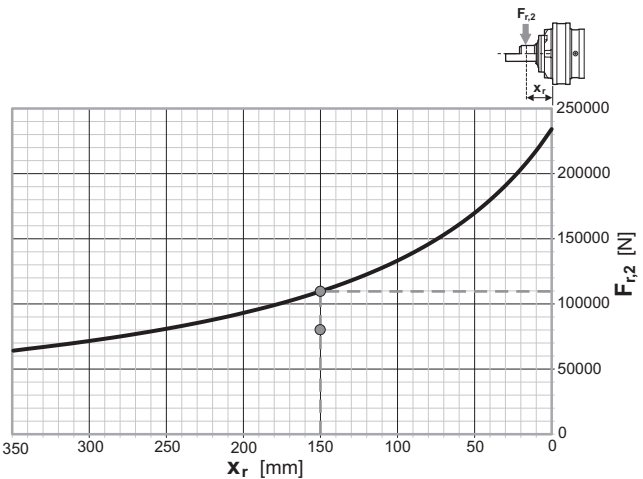

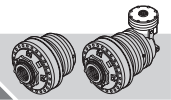

Exemple 1

Connaissant la position de la charge radiale $x = 150\text{mm}$ et le facteur de durée exigé $n_2 \cdot h = 500000$, on cherche la charge radiale $F_{r,2}$ applicable sur l'arbre à la sortie du réducteur RR2500 MS.

Ejemplo 1

Conocida la posición de la carga radial $x=150\text{mm}$ y el factor de duración requerido $n_2 \cdot h = 500000$, se desea conocer la carga radial $F_{r,2}$ aplicable sobre el eje de salida del reductor RR2500 MS.

Exemplo 1

Conhecida a posição da carga radial $x = 150\text{mm}$ e o fator de duração necessário $n_2 \cdot h = 500000$, deseja-se conhecer a carga radial $F_{r,2}$ aplicável no eixo saída do redutor RR2500 MS.

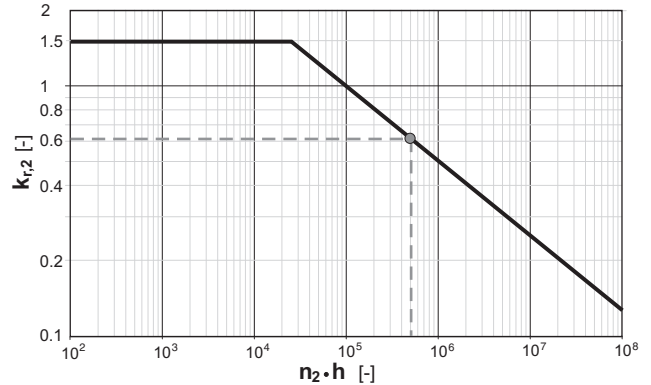
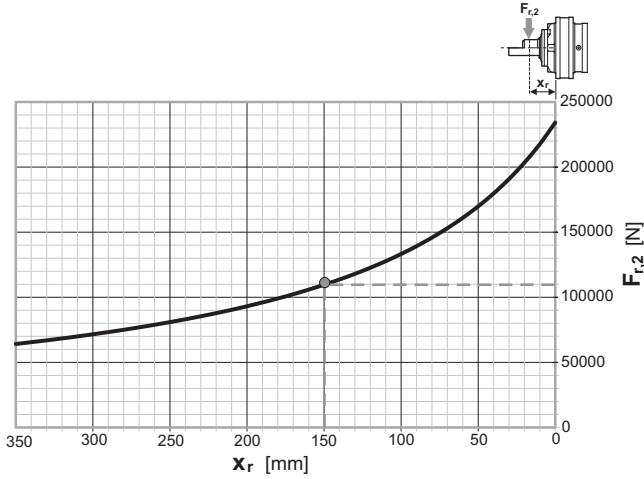

A partir du graphique de la charge radiale, on obtient la valeur nominale applicable à 150mm, égale à 110000N. Cette valeur doit être corrigée par le facteur $k_{r,2}$ pour tenir compte du facteur de durée différent de 10^5 ; à partir du deuxième graphique, à la hauteur de l'abscisse, $n_2 \cdot h = 500000$, on trouve la valeur de $k_{r,2}$ cherchée, égale à 0.62.

Del gráfico de la carga radial se saca el valor nominal aplicable a 150mm, que vale 110000N. Este valor se debe corregir a través del factor $k_{r,2}$ para tener en cuenta el factor de duración distinto de 10^5 ; del segundo gráfico, en correspondencia con la abscisa, $n_2 \cdot h = 500000$, se saca el valor de $k_{r,2}$ buscado, que vale 0.62.

Da gráfico da carga radial obtém-se o valor nominal aplicável a 150 mm, equivalente a 110000 N. Este valor deve ser corrigido através do fator $k_{r,2}$ para considerar o fator de duração diferente de 10^5 ; do segundo gráfico, em correspondência da abscissa $n_2 \cdot h = 500000$, obtém-se o valor de $k_{r,2}$ procurado, equivalente a 0.62.

La charge radiale maximum qu'il est possible d'appliquer en position x est donc égale à:

Por lo tanto, la carga radial máxima que es posible aplicar en la posición x es:

Portanto, a carga radial máxima que é possível aplicar na posição x é igual a:

$$F_{r,2} = F_{r,2nom} \cdot k_{r,2} = 110000 \cdot 0.62 = 68200 \text{ N}$$

Exemple 2

Connaissant la position de la charge radiale $x=150\text{mm}$ et sa valeur $F_{r,2}=80000\text{N}$, on cherche le facteur de durée du support à la sortie pour le réducteur RR2500 MS.

Ejemplo 2

Conocida la posición de la carga radial $x=150\text{mm}$ y su valor $F_{r,2}=80000\text{N}$, se desea determinar el factor de duración del soporte de salida para el reductor RR2500 MS.

Exemplo 2

Conhecida a posição da carga radial $x = 150 \text{ mm}$ e o seu valor $F_{r,2} = 80000\text{N}$, deseja-se calcular o fator de duração do suporte saída para o redutor RR2500 MS.

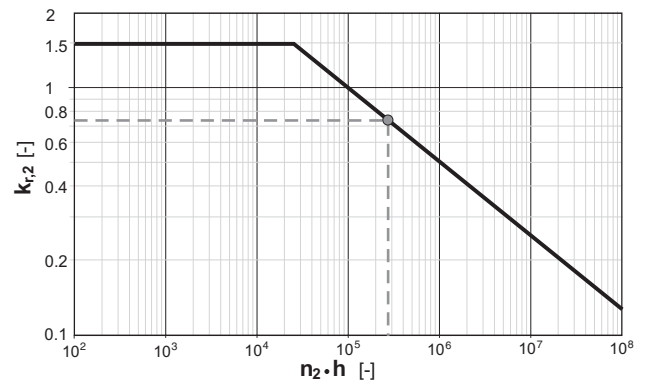
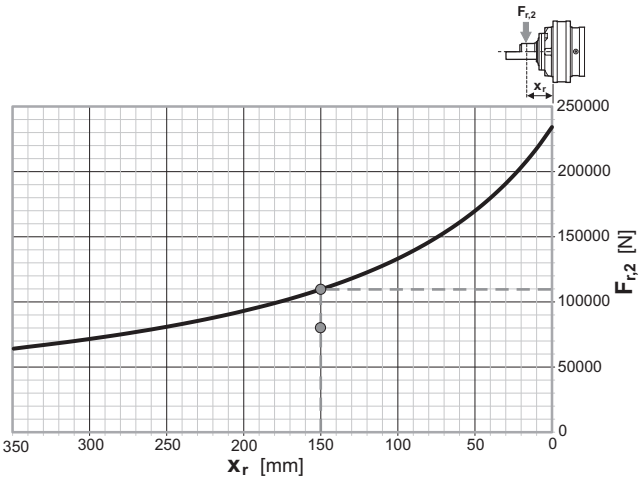

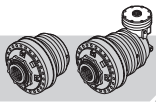

Dal rapporto tra il carico nominale applicabile in x, pari a 110000N, ed il carico applicato si ottiene il fattore correttivo $k_{r,2}$:

From the ratio between the nominal load applicable in x, equal to 110000N, and the load applied, we have the corrective coefficient $k_{r,2}$:

Aus dem Verhältnis von anlegbarer Nennlast in x, die 110000N entspricht, und angelegter Last erhält man den Korrekturfaktor $k_{r,2}$:

$$k_{r,2} = \frac{F_{r,2}}{F_{r,2nom}} = \frac{80000}{110000} = 0.73$$

Nel grafico del fattore correttivo, in corrispondenza di questo valore di $k_{r,2}$ si trova un valore del fattore di durata, pari a circa 280000 $n_2 \cdot h$.

In the corrective coefficient graph, where we find the $k_{r,2}$ value, we find a value of the duration factor which is equivalent to about 280000 $n_2 \cdot h$.

In der Kurve vom Korrekturfaktor kann auf Höhe von diesem Wert $k_{r,2}$ der Wert vom Zeitfaktor abgelesen werden, der ca. 280000 $n_2 \cdot h$ entspricht.

5.4 Verifica della potenza termica

5.4 Checking thermal power

5.4 Kontrolle der Wärmeleistung

Se la potenza trasmessa dal riduttore, ossia la potenza richiesta in entrata P_{r1} , è superiore alla potenza termica P_t è necessario predisporre un sistema di raffreddamento ausiliario. Poiché il valore della potenza termica dei riduttori è calcolato nell'ipotesi di $t_a=20^\circ\text{C}$ e $n_1=1000 \text{ min}^{-1}$, quando le reali condizioni di funzionamento si discostano da questa condizione è necessario correggere il valore di P_t mediante i fattori K_t , fattore di temperatura, e K_v , fattore di velocità, ricavabili dalle tabelle che seguono:

If the power transmitted by the reduction gear, that is, the power required in input P_{r1} , is higher than thermal power P_t an auxiliary cooling system is necessary. Since the value of the reduction gears' thermal power is calculated hypothesising $t_a=20^\circ\text{C}$ and $n_1=1000 \text{ min}^{-1}$, when the actual operating conditions deviate from this condition the P_t value has to be corrected by means of the K_t factors, the temperature factor, and K_v and the speed factor which can be found in the following tables:

Wenn die vom Planetengetriebe übertragene Leistung, d.h. die am Eingang verlangte Leistung P_{r1} größer ist als die Wärmeleistung P_t , muss ein zusätzliches Kühlsystem vorgesehen werden. Da der Wert der Wärmeleistung der Planetengetriebe unter der Annahme berechnet wird, dass $t_a=20^\circ\text{C}$ und $n_1=1000 \text{ min}^{-1}$, muss der Wert P_t bei Abweichung von diesen Bedingungen mit dem Temperaturfaktor K_t und dem Geschwindigkeitsfaktor K_v korrigiert werden, die den Tabellen unten entnommen werden können:

K_t	minuti di funzionamento / ora minutes operating/hour Minuten Betrieb/pro Stunde		t_a						n_1 [min ⁻¹]	K_v
			10°C	20°C	30°C	40°C	50°C	60°C		
Servizio continuo Continuous duty Dauerbetrieb	60	100%	0.9	1	1.15	1.4	1.75	2.35	500	1.08
									750	1.04
Servizio intermittente Intermittent duty Aussetzbetrieb	48	80%	0.8	0.9	1.05	1.25	1.55	2.1	1000	1.00
	36	60%	0.7	0.8	0.95	1.1	1.4	1.85	1250	0.95
	24	40%	0.6	0.7	0.8	0.95	1.2	1.6	1500	0.89
	12	20%	0.5	0.6	0.7	0.8	1.05	1.35	1750	0.82
									2000	0.75
									2250	0.66
									2500	0.59
									2750	0.54
									3000	0.48

La potenza termica corretta P'_t si calcola con la formula:

The corrected thermal power P'_t is calculated with the formula:

Die korrigierte Wärmeleistung P'_t wird anhand folgender Formel berechnet:

$$P'_t = \frac{P_t \cdot K_v}{K_t}$$

Se risulta $P_{r1} > P'_t$ occorre installare un sistema ausiliario di raffreddamento per smaltire la potenza termica in eccesso, ricavabile dalla formula:

If the result is $P_{r1} > P'_t$ an auxiliary cooling system has to be installed to get rid of the thermal power in excess, found with the formula:

Wenn $P_{r1} > P'_t$ muss ein zusätzliches Kühlsystem installiert werden, um die übermäßige Wärmeleistung abzuleiten, die anhand folgender Formel berechnet werden kann:

$$P_s = \frac{(P_{r1} - P'_t) \cdot C_{rt}}{860}$$

in cui C_{rt} è un coefficiente che si ricava dalla tabella che segue, in base alla configurazione del riduttore e al tipo di riempimento (illustrato più avanti nel capitolo sulla lubrificazione).

where C_{rt} is a coefficient that is found in the following table, based on the configuration of the reduction gear and on the filling up type (illustrated further on in the lubricating chapter).

wobei der Koeffizient C_{rt} anhand der Konfiguration vom Planetengetriebe und der Art der Füllung der Tabelle unten entnommen werden kann (siehe auch Kapitel Schmierung).

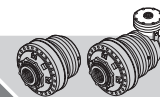

Sur la base du rapport entre la charge nominale applicable en x, égale à 110000N, et la charge appliquée, on obtient le facteur correctif $k_{r,2}$:

De la relación entre la carga nominal aplicable en x, que vale 110000N, y la carga aplicada se obtiene el factor de corrección $k_{r,2}$:

Da relação entre a carga nominal aplicável em x, equivalente a 110000N, e a carga aplicada obtém-se o fator corretivo $k_{r,2}$:

$$k_{r,2} = \frac{F_{r,2}}{F_{r,2nom}} = \frac{80000}{110000} = 0.73$$

Sur le graphique du facteur correctif, correspondant à cette valeur de $k_{r,2}$ on trouve une valeur du facteur de durée, égale à environ 280000 $n_2 \cdot h$.

En el gráfico del factor de corrección, en correspondencia con este valor de $k_{r,2}$ tenemos un valor del factor de duración, que vale aproximadamente 280000 $n_2 \cdot h$.

No gráfico do fator corretivo, em correspondência deste valor de $k_{r,2}$ encontra-se um valor do fator de duração, igual a cerca de 280000 $n_2 \cdot h$.

5.4 Contrôle de la puissance thermique

Si la puissance transmise du réducteur, c'est-à-dire la puissance exigée à l'entrée P_{r1} , est supérieure à la puissance thermique P_t , il est nécessaire de prévoir un système auxiliaire de refroidissement. La valeur de la puissance thermique des réducteurs étant calculée dans l'hypothèse de $t_a=20^\circ\text{C}$ et $n_1=1000 \text{ mn}^{-1}$, quand les conditions de fonctionnement réelles s'écartent de cette condition, il faut corriger la valeur de P_t par les facteurs K_t , facteur de température, et K_v , facteur de vitesse, qu'on peut trouver sur les tableaux suivants:

5.4 Comprobación de la potencia térmica

Si la potencia transmitida por el reductor, es decir la potencia requerida en entrada P_{r1} , es mayor que la potencia térmica P_t entonces es necesario predisponer un sistema de refrigeración auxiliar. Puesto que el valor de la potencia térmica de los reductores está calculado en el supuesto de $t_a=20^\circ\text{C}$ y $n_1=1000 \text{ min}^{-1}$, cuando las condiciones reales de funcionamiento difieren de esta condición es necesario corregir el valor de P_t utilizando los factores K_t , factor de temperatura, y K_v , factor de velocidad, que se pueden sacar de las tablas siguientes:

5.4 Verificação da potência térmica

Se a potência transmitida pelo redutor, ou seja, a potência necessária em entrada P_{r1} , é superior à potência térmica P_t é necessário preparar um sistema de arrefecimento auxiliar. Considerando que o valor da potência térmica dos redutores é calculado na hipótese de $t_a = 20^\circ\text{C}$ e $n_1 = 1000 \text{ min}^{-1}$, quando as reais condições de funcionamento se afastam desta condição é necessário corrigir o valor de P_t mediante os fatores K_t , fator de temperatura, e K_v , fator de velocidade, que se podem obter nas seguintes tabelas:

K_t	minutes de fonctionnement/h Minutos de funcionamiento / hora minutos de funcionamento / hora		t_a						n_1 [min ⁻¹]	K_v
			10°C	20°C	30°C	40°C	50°C	60°C		
Service continu Servicio continuo Serviço contínuo	60	100%	0.9	1	1.15	1.4	1.75	2.35	500	1.08
									750	1.04
									1000	1.00
Service intermittent Servicio intermitente Serviço intermitente	48	80%	0.8	0.9	1.05	1.25	1.55	2.1	1250	0.95
	36	60%	0.7	0.8	0.95	1.1	1.4	1.85	1500	0.89
	24	40%	0.6	0.7	0.8	0.95	1.2	1.6	1750	0.82
	12	20%	0.5	0.6	0.7	0.8	1.05	1.35	2000	0.75
									2250	0.66
								2500	0.59	
								2750	0.54	
								3000	0.48	

La puissance thermique corrigée P'_t se calcule en appliquant la formule suivante:

La potencia térmica corregida P'_t se calcula con la fórmula:

A potência térmica corrigida P'_t é calculada com a seguinte fórmula:

$$P'_t = \frac{P_t \cdot K_v}{K_t}$$

Si $P_{r1} > P'_t$ il faut installer un système auxiliaire de refroidissement pour évacuer la puissance thermique en excès, qu'on peut trouver en appliquant la formule suivante:

Si resulta $P_{r1} > P'_t$ es necesario instalar un sistema auxiliar de refrigeración para eliminar la potencia térmica en exceso, que se puede obtener con la fórmula:

Se resulta $P_{r1} > P'_t$ é necessário instalar um sistema auxiliar de arrefecimento para eliminar a potência térmica em excesso, que se pode obter através da fórmula:

$$P_s = \frac{(P_{r1} - P'_t) \cdot C_{rt}}{860}$$

où C_{rt} est un coefficient qu'on trouve dans le tableau ci-dessous, en fonction de la configuration du réducteur et du type de remplissage (illustré plus loin dans le chapitre sur la lubrification).

Donde C_{rt} es un coeficiente que se saca de la tabla siguiente, según la configuración del reductor y el tipo de llenado (ilustrado más adelante en el capítulo sobre la lubricación).

na qual C_{rt} é um coeficiente que se obtém através da tabela que segue, com base na configuração do redutor e do tipo de enchimento (ilustrado mais adiante no capítulo relativo à lubrificação).

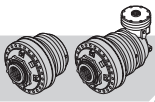

C_{rt}	Metà riempimento Filled half way Halb gefüllt	Pieno riempimento Filled to the top Ganz gefüllt
L1	22	26
L2/A2	42	51
L3/A3	63	75
L4/A4	83	99

La portata di olio in litri al minuto, necessaria per smaltire la potenza P_s si calcola come:

The flow rate of oil in litres a minute, necessary to get rid of power P_s , is calculated as:

Der Öldurchsatz in Litern pro Minute, der zum Ableiten der Leistung P_s erforderlich ist, wird wie folgt berechnet:

$$q = \frac{(P_{r1} - P'_t) \cdot C_{rt} \cdot 0.07}{t_R - t_S}$$

dove t_R e t_S sono rispettivamente la temperatura di funzionamento del riduttore (ovvero la temperatura dell'olio all'interno del riduttore) e la temperatura dell'olio in uscita dallo scambiatore.

where t_R and t_S are, respectively, the reduction gear operating temperature (that is, the temperature of the oil inside the reduction gear) and the temperature of the oil leaving the exchanger.

wobei t_R und t_S die Betriebstemperatur vom Planetengetriebe (d.h. die Öltemperatur im Planetengetriebe) bzw. die Öltemperatur am Ausgang vom Wärmeaustauscher sind.

Esempio

Un riduttore RR2500 L3 funziona alle seguenti condizioni:

- velocità in ingresso $n_1=1500 \text{ min}^{-1}$;
- potenza richiesta in ingresso $P_{r1} = 26 \text{ kW}$;
- metà riempimento;
- temperatura ambiente $t_a=40^\circ\text{C}$;
- 36 minuti di funzionamento ogni ora.

Example

An RR2500 L3 reduction gear works at the following conditions:

- input speed $n_1=1500 \text{ min}^{-1}$;
- power required in input $P_{r1} = 26 \text{ kW}$;
- filled halfway;
- ambient temperature $t_a=40^\circ\text{C}$;
- 36 minutes working every hour.

Beispiel

Ein Planetengetriebe RR2500 L3 funktioniert unter folgenden Bedingungen:

- Geschwindigkeit am Eingang $n_1=1500 \text{ min}^{-1}$;
- verlangte Leistung am Eingang $P_{r1} = 26 \text{ kW}$;
- halbe Füllung;
- Umgebungstemperatur $t_a=40^\circ\text{C}$;
- 36 Minuten Betrieb pro Stunde.

Dalla tabella dei dati tecnici dei riduttori RR2500 si ricava il valore di potenza termica $P_t=17 \text{ kW}$ del riduttore in oggetto, che deve essere corretto introducendo i fattori K_t e K_v ottenuti dalle rispettive tabelle:

The thermal power value $P_t=17 \text{ kW}$ of the subject reduction gear is found in the RR2500 reduction gears table and has to be corrected by introducing factors K_t and K_v taken from the relative tables:

Aus der Tabelle mit den technischen Daten der Planetengetriebe RR2500 kann der Wert für die Wärmeleistung $P_t=17 \text{ kW}$ vom Planetengetriebe entnommen werden. Dieser Wert muss mit den Faktoren K_t und K_v korrigiert werden, die den jeweiligen Tabellen entnommen werden können:

$$P'_t = \frac{P_t \cdot K_v}{K_t} = \frac{17 \cdot 0.89}{1.10} = 13.75 \text{ kW}$$

Poiché la potenza richiesta è maggiore della potenza termica che il riduttore è in grado di smaltire, occorre installare un sistema ausiliario di raffreddamento per smaltire una potenza pari a:

Since the power required is greater than the thermal power the reduction gear is able to get rid of, an auxiliary cooling system needs to be installed to get rid of a power equivalent to:

Da die verlangte Leistung größer ist als die Wärmeleistung, die das Planetengetriebe ableiten kann, muss ein zusätzliches Kühlsystem zur Wärmeableitung mit folgender Leistung installiert werden:

$$P_s = \frac{(P_{r1} - P'_t) \cdot C_{rt}}{860} = \frac{(26 - 13.75) \cdot 63}{860} = 0.90 \text{ kW}$$

dove il valore di C_{rt} è stato ricavato dall'apposita tabella per il riduttore L3.

where the C_{rt} value was taken from the relative table for the L3 reduction gear.

wobei der Wert C_{rt} der entsprechenden Tabelle für das Planetengetriebe L3 entnommen werden kann.

Utilizzando un sistema di raffreddamento a ricircolo d'olio, supponendo che la temperatura dell'olio entrante nello scambiatore è $t_R=90^\circ\text{C}$ mentre quella uscente è $t_S=65^\circ\text{C}$, la portata necessaria a smaltire tale potenza è pari a:

Utilising an oil recirculating cooling system, assuming that the temperature of the oil entering the exchanger is $t_R=90^\circ\text{C}$ while when it leaves the exchanger it is $t_S=65^\circ\text{C}$, the rate necessary to get rid of such a power is equivalent to:

Bei Einsatz eines Kühlsystems mit Ölrücklauf und unter der Annahme, dass die Temperatur vom Öl am Eingang vom Wärmeaustauscher $t_R=90^\circ\text{C}$ und am Ausgang $t_S=65^\circ\text{C}$ beträgt, ist folgender Durchsatz zur Ableitung der Wärmeleistung erforderlich:

$$q = \frac{(P_{r1} - P'_t) \cdot C_{rt} \cdot 0.07}{t_R - t_S} = \frac{(26 - 13.75) \cdot 63 \cdot 0.07}{90 - 65} = 2.16 \text{ l/min}$$

Consultare il capitolo relativo alla lubrificazione per la scelta del sistema ausiliario di raffreddamento più idoneo tra quelli proposti.

Consult the lubrication chapter to choose the most suitable auxiliary cooling system out of those proposed.

Nähere Informationen zur Auswahl vom geeigneten zusätzlichen Kühlsystem können dem Kapitel "Schmierung" entnommen werden.



C_{rt}	Remplissage à moitié <i>Mitad llenado</i> Meio enchimento	Remplissage plein <i>Llenado completo</i> Enchimento completo
	L1	22
L2/A2	42	51
L3/A3	63	75
L4/A4	83	99

Le débit d'huile en litres/minute, nécessaire pour évacuer la puissance P_s se calcule de la manière suivante:

El caudal de aceite en litros por minuto, necesario para eliminar la potencia P_s se calcula como:

A capacidade de óleo em litros por minuto, necessária para eliminar a potência P_s calcula-se como:

$$q = \frac{(P_{r1} - P'_t) \cdot C_{rt} \cdot 0.07}{t_R - t_S}$$

où t_R et t_S sont respectivement la température de fonctionnement du réducteur (c'est-à-dire la température de l'huile à l'intérieur du réducteur) et la température de l'huile à la sortie de l'échangeur.

Donde t_R y t_S son, respectivamente, la temperatura de funcionamiento del reductor (es decir la temperatura del aceite dentro del reductor) y la temperatura del aceite en salida del intercambiador.

onde t_R e t_S são, respetivamente, a temperatura de funcionamento do redutor (ou seja, a temperatura do óleo no interior do redutor) e a temperatura do óleo à saída do permutador.

Exemple

Un réducteur RR2500 L3 fonctionne aux conditions suivantes:

- vitesse à l'entrée $n_1=1500 \text{ min}^{-1}$;
- puissance exigée à l'entrée $P_{r1} = 26 \text{ kW}$;
- remplissage à moitié ;
- température ambiante $t_a=40^\circ\text{C}$;
- 36 minutes de fonctionnement/h.

A partir du tableau des caractéristiques techniques des réducteurs RR2500, on trouve la valeur de puissance thermique $P_t=17 \text{ kW}$ du réducteur en objet, qui doit être corrigée en introduisant les facteurs K_t et K_v obtenus à partir des tableaux respectifs:

Ejemplo

Un reductor RR2500 L3 funciona en las siguientes condiciones:

- *velocidad en entrada $n_1=1500 \text{ min}^{-1}$;*
- *potencia requerida en entrada $P_{r1} = 26 \text{ kW}$;*
- *mitad llenado;*
- *temperatura ambiente $t_a=40^\circ\text{C}$;*
- *36 minutos de funcionamiento cada hora.*

En la tabla de los datos técnicos de los reductores RR2500 sacamos el valor de potencia térmica $P_t=17 \text{ kW}$ del reductor considerado, que se debe corregir introduciendo los factores K_t y K_v obtenidos de las respectivas tablas:

Exemplo

Um redutor RR2500 L3 funciona às seguintes condições:

- velocidade em entrada $n_1=1500 \text{ min}^{-1}$;
- potência necessária em entrada $P_{r1} = 26 \text{ kW}$;
- meio enchimento;
- temperatura ambiente $t_a=40^\circ\text{C}$;
- 36 minutos de funcionamento cada hora.

Através da tabela dos dados técnicos dos redutores RR2500 obtém-se o valor de potência térmica $P_t = 17 \text{ kW}$ do redutor em objeto, que deve ser corrigido introduzindo os fatores K_t e K_v obtidos pelas respetivas tabelas:

$$P'_t = \frac{P_t \cdot K_v}{K_t} = \frac{17 \cdot 0.89}{1.10} = 13.75 \text{ kW}$$

La puissance exigée étant supérieure à la puissance thermique que le réducteur est en mesure d'évacuer, il faut installer un système auxiliaire de refroidissement pour évacuer une puissance égale à:

Puesto que la potencia requerida es mayor que la potencia térmica que el reductor logra eliminar, es necesario instalar un sistema auxiliar de refrigeración para eliminar una potencia igual que:

Dado que a potência necessária é maior do que a potência térmica que o redutor é capaz de eliminar, é necessário instalar um sistema auxiliar de arrefecimento para eliminar uma potência equivalente a:

$$P_s = \frac{(P_{r1} - P'_t) \cdot C_{rt}}{860} = \frac{(26 - 13.75) \cdot 63}{860} = 0.90 \text{ kW}$$

où la valeur de C_{rt} a été trouvée par l'intermédiaire du tableau pour le réducteur L3.

Donde el valor de C_{rt} se ha sacado de la correspondiente tabla para el reductor L3.

onde o valor de C_{rt} foi obtido na respetiva tabela para o redutor L3.

En utilisant un système de refroidissement à recirculation d'huile, en supposant que la température de l'huile entrant dans l'échangeur est $t_R=90^\circ\text{C}$ alors que la température de l'huile sortant est $t_S=65^\circ\text{C}$, le débit nécessaire à évacuer cette puissance est égal à:

Utilizando un sistema de refrigeración por recirculación de aceite, suponiendo que la temperatura del aceite entrante en el intercambiador es $t_R=90^\circ\text{C}$ mientras que la de salida es $t_S=65^\circ\text{C}$, el caudal necesario para eliminar dicha potencia es de:

Utilizando um sistema de arrefecimento de recirculação de óleo, supondo que a temperatura do óleo que entra no permutador é $t_R = 90^\circ\text{C}$ enquanto que aquele que sai é $t_S = 65^\circ\text{C}$, o caudal necessário para eliminar tal potência é equivalente a:

$$q = \frac{(P_{r1} - P'_t) \cdot C_{rt} \cdot 0.07}{t_R - t_S} = \frac{(26 - 13.75) \cdot 63 \cdot 0.07}{90 - 65} = 2.16 \text{ l/min}$$

Voir le chapitre relatif à la lubrification pour choisir le système auxiliaire de refroidissement le plus adapté parmi ceux qui sont proposés.

Consultese el capítulo correspondiente a la lubricación para la selección del sistema auxiliar de refrigeración más idóneo entre los propuestos.

Consultar o capítulo relativo à lubrificação para a escolha do sistema auxiliar de arrefecimento mais idóneo entre aqueles propostos.

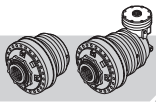

6 LUBRIFICAZIONE

Salvo diverse indicazioni, tutti i riduttori sono forniti privi di olio lubrificante; è compito dell'utilizzatore effettuare il riempimento prima della messa in servizio.

L'olio lubrificante all'interno di un riduttore epicicloidale ha il compito di:

- ridurre l'attrito tra gli organi di trasmissione, aumentandone il rendimento;
- contribuire allo smaltimento del calore, trasferendolo dagli organi in movimento alla carcassa;
- proteggere le superfici dalla formazione di ruggine;
- ridurre la rumorosità.



Una corretta lubrificazione assicura un buon funzionamento ed una lunga durata del riduttore.

6 LUBRICATION

Unless specified otherwise, all reduction gears are supplied without lubricant oil; the user has to fill up prior to commissioning.

The lubricant oil inside a planetary reduction gear has the job of:

- *reducing friction between the transmission parts, increasing their efficiency;*
- *helping to get rid of heat, transferring it from the moving parts to the casing;*
- *protecting surfaces from going rusty;*
- *reducing noise.*

Correct lubrication ensures good operation and a long life of the reduction gear.

6 SCHMIERUNG

Vorbehaltlich anders lautender Angaben werden alle Planetengetriebe ohne Schmieröl geliefert. Der Benutzer ist deshalb dafür zuständig, das Öl vor der Inbetriebnahme einzufüllen.

Das Schmieröl im Planetengetriebe hat die Aufgabe:

- die Reibung zwischen den Antriebsorganen zu reduzieren und damit den Wirkungsgrad zu verbessern;
- zur Wärmeableitung beizutragen, und zwar durch Übertragung der Wärme von den laufenden Getriebeteilen auf das Gehäuse;
- die Oberflächen vor Rostbildung zu schützen;
- den Lärmpegel zu reduzieren.

Eine korrekte Schmierung garantiert für einen störungsfreien Betrieb und eine lange Lebensdauer des Planetengetriebes.

6.1 Viscosità

La viscosità cinematica del lubrificante deve essere scelta in funzione della temperatura di esercizio e della velocità di rotazione.

Poiché la viscosità diminuisce al crescere della temperatura, per temperature di funzionamento elevate è opportuno scegliere un olio con classe di viscosità maggiore.

Nel caso di riduzioni molto lente (velocità in uscita n_2 inferiore a 5 min^{-1}) si consiglia di utilizzare un olio con classe di viscosità elevata; viceversa, nel caso di riduttore con elevata velocità di rotazione si consiglia di impiegare un olio con classe di viscosità bassa.

6.2 Additivi

L'uso di additivi di tipo EP (Extreme Pressure) serve a diminuire l'usura superficiale di ingranaggi e cuscinetti. Questi additivi, infatti, sotto l'effetto del calore e della pressione tra le superfici sottoposte a carico, reagiscono chimicamente con le superfici stesse, formando un rivestimento protettivo che impedisce la formazione di micro-saldature ed il conseguente grippaggio.

6.1 Viscosity

The lubricant's kinematic viscosity must be chosen in accordance with both the operating temperature and rotation speed.

Since viscosity diminishes as the temperature rises, for high operating temperatures it is advisable to choose a higher viscosity class oil.

In the case of very slow reductions (input speed below 5 min^{-1}) we recommend using a high viscosity class oil or, vice versa, in the case of reduction gears with a high rotation speed, we recommend using a low viscosity class oil.

6.2 Additives

The use of EP type additives (Extreme Pressure) helps reduce surface wear of the gears and bearings. As a matter of fact, these additives, under the effect of the heat and pressure between surfaces subject to load, react chemically with the same surfaces, forming a protective coating that prevents the formation of micro-weldings and consequent seizure.

6.1 Viskosität

Die kinematische Viskosität vom Schmiermittel muss in Abhängigkeit von der Betriebstemperatur und der Rotationsgeschwindigkeit gewählt werden.

Da die Viskosität mit steigender Temperatur abnimmt, müssen für Anwendungen mit hohen Betriebstemperaturen Öle einer größeren Viskositätsklasse gewählt werden.

Bei sehr langsamen Planetengetrieben (Geschwindigkeit am Ausgang n_2 unter 5 min^{-1}) wird zur Verwendung von Ölen mit einer hohen Viskosität geraten. Umgekehrt gilt, dass für Planetengetriebe mit hoher Rotationsgeschwindigkeit Öle mit einer niedrigen Viskosität verwendet werden sollten.

6.2 Additive

Durch die Verwendung von Additiven vom Typ EP (Extreme Pressure) wird der Oberflächenverschleiß von Zahnrädern und Lagern reduziert. Diese Additive unter Einwirkung der Wärme und dem Druck zwischen den belasteten Oberflächen eine chemische Reaktion mit den Oberflächen aus, die zur Bildung einer Schutzschicht führt, welche die Ausbildung von Mikroschweißungen und das daraus folgende Festfressen verhindert.

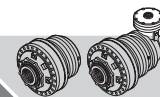

6 LUBRIFICATION

A moins d'indications différentes, tous les réducteurs sont livrés sans huile de lubrification; c'est à l'utilisateur d'effectuer le nourrissage avant la mise en service du réducteur.

Le rôle de l'huile de lubrification à l'intérieur d'un réducteur épicycloïdal est de:

- réduire le frottement entre les organes de transmission, ce qui contribue à augmenter leur rendement;
- contribuer à l'évacuation de la chaleur, en faisant passer des organes en mouvement au bâti;
- protéger les surfaces de la formation de rouille;
- réduire les nuisances sonores.



Une lubrification correcte assure un bon fonctionnement et une durabilité majeure du réducteur.

6 LUBRICACIÓN

Salvo indicaciones contrarias, todos los reductores son suministrados sin aceite lubricante; es tarea del usuario efectuar el llenado antes de ponerlos en servicio.

El aceite lubricante dentro de un reductor epicycloidal tiene la tarea de:

- *reducir la fricción entre los órganos de transmisión, aumentando su rendimiento;*
- *contribuir en la eliminación del calor, transfiriéndolo desde los órganos en movimiento a la carcasa;*
- *proteger las superficies contra la formación de óxido;*
- *reducir el ruido.*

Una lubricación correcta asegura un buen funcionamiento y una larga duración del reductor.

6 LUBRIFICAÇÃO

Salvo diversas indicações, todos os reductores são fornecidos sem óleo lubrificante e portanto o usuário deve efetuar o enchimento antes da entrada em funcionamento.

O óleo lubrificante no interior de um reductor epicycloidal tem a função de:

- reduzir o atrito entre os órgãos de transmissão, aumentando o seu rendimento;
- contribuir para a eliminação do calor, transferindo-o dos órgãos em movimento para a carcaça;
- proteger as superfícies contra a formação de ferrugem;
- reduzir o nível de barulho.

Uma correta lubrificação garante o bom funcionamento e a longevidade do reductor.

6.1 Viscosité

La viscosité cinématique du lubrifiant doit être choisie en fonction de la température de fonctionnement et de la vitesse de rotation.

La viscosité diminuant au fur et à mesure que la température monte, pour des températures de fonctionnement élevées, il est recommandé de choisir une huile ayant une classe de viscosité supérieure. En cas de réductions très lentes (vitesse à la sortie n_2 inférieure à 5 mn^{-1}) il est conseillé d'utiliser une huile ayant une classe de viscosité élevée; vice-versa, dans le cas de réducteur dont la vitesse de rotation est rapide, il est conseillé de choisir une huile ayant une classe de viscosité basse.

6.2 Additifs

L'emploi d'additifs de type EP (Extreme Pressure) permet de diminuer l'usure des surfaces des engrenages et des roulements. En effet, sous l'effet de la chaleur et de la pression entre les surfaces soumises à la charge, ces additifs réagissent chimiquement avec les surfaces en question, en formant un revêtement protecteur qui empêche la formation de micro-soudures et par conséquent le grippage.

6.1 Viscosidad

Se debe seleccionar la viscosidad cinemática del lubricante en función de la temperatura de funcionamiento y de la velocidad de rotación.

Puesto la viscosidad disminuye al aumentar la temperatura, para altas temperaturas de funcionamiento es oportuno elegir un aceite con clase de viscosidad mayor. En el caso de reducciones muy lentas (velocidad en salida n_2 por debajo de 5 mir^{-1}) se aconseja utilizar un aceite con alta clase de viscosidad; viceversa, en caso de reductor con alta velocidad de rotación se aconseja utilizar un aceite con baja clase de viscosidad.

6.2 Aditivos

El uso de aditivos de tipo EP (Extreme Pressure) sirve para reducir el desgaste superficial de engranajes y cojinetes. Estos aditivos, efectivamente, bajo el efecto del calor y de la presión entre las superficies sometidas a carga, reaccionan químicamente con las propias superficies, formando un revestimiento protector que impide la formación de micro-soldaduras con consiguiente agarrotamiento.

6.1 Viscosidade

A viscosidade cinemática do lubrificante deve ser escolhida em função da temperatura de exercício e da velocidade de rotação.

Dado que a viscosidade diminui ao aumentar da temperatura, no caso de temperaturas elevadas de funcionamento é oportuno escolher um óleo com classe de viscosidade superior.

No caso de reduções muito lentas (velocidade em saída n_2 inferior a 5 min^{-1}) aconselhamos usar um óleo com classe de viscosidade elevada; vice-versa, no caso de reductor com elevada velocidade de rotação aconselhamos usar um óleo com classe de viscosidade baixa.

6.2 Aditivos

O uso de aditivos de tipo EP (Extreme Pressure) serve para diminuir o desgaste superficial de engrenagens e rolamentos. De fato, estes aditivos, sob o efeito do calor e da pressão entre as superfícies submetidas a carga, reagem quimicamente com as próprias superfícies, formando um revestimento de proteção que impede a formação de micro-soldaduras e a consequente gripagem.

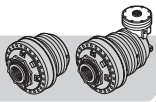

6.3 Contaminazione

Durante le prime ore di funzionamento dei riduttori, a causa del contatto tra le superfici non rodiate, si verifica una diffusione di particelle metalliche nell'olio. La presenza di queste particelle ha un effetto certamente negativo sulla durata di vita di ingranaggi e cuscinetti.

Per ridurre la presenza di particelle metalliche nell'olio si consiglia di:

- effettuare la sostituzione dell'olio dei riduttori e dei freni dopo le prime 100 ore di funzionamento e successivamente ogni 1500- 2000h od ogni 12 mesi;
- pulire periodicamente i tappi magnetici;
- eseguire il filtraggio dell'olio, mediante un sistema ausiliario di raffreddamento.

I tipi di lubrificante consigliati sono indicati nelle tabelle seguenti:

6.3 Contamination

During the first hours of operation of the reduction gears, due to the contact between surfaces that have not been run-in, you will find metallic particles in the oil. Undoubtedly these particles have a negative effect on the life of gears and bearings.

To reduce the number of metallic particles in the oil we recommend:

- *changing the oil of the gearboxes and brakes after the first 100 hours of working and then every 1500-2000 hours or every 12 months.;*
- *cleaning the magnetic plugs regularly;*
- *filtering the oil by means of an auxiliary cooling system.*

The recommended lubricants are listed in the following table:

6.3 Verunreinigungen

Während der ersten Betriebsstunden der Planetengetriebe gelangen durch den Kontakt der nicht eingelaufenen Oberflächen Metallpartikel ins Öl. Das Vorhandensein dieser Metallpartikel wird sich deutlich zum Nachteil der Lebensdauer von Zahnrädern und Lagern aus.

Zur Reduzierung der Metallpartikel im Öl wie folgt vorgehen:

- Nach den ersten 100 Betriebsstunden einen Ölwechsel durchführen der planetengetriebe und die Bremsen, dann alle 1500-2000 Betriebsstunden, mindestens aber alle 12 Monate;
- Die Magnetdeckel regelmäßig sauber machen;
- Das Öl mit einem zusätzlichen Kühlsystem filtern.

Die empfohlenen Schmiermittel können der Tabelle unten entnommen werden:

Lubrificanti per uso generale

General purpose lubricants

Schmiermittel für allgemeinen Gebrauch

Temperatura ambiente Ambient temperature Umgebungstemperatur	Oli Minerali Mineral oils Mineralöle			Oli Sintetici Polialfaolefine (PAO) Poly-Alpha-Olefin synthetic oils (PAO) Synthetische Poly-Alpha-Olefin-Öle (PAO)			Oli Sintetici Poliglicoli (PG) Polyglycol synthetic oils (PG) Synthetische Polyglykolöle (PG)		
	-10°C/+30°C	+10°C/+45°C	+30°C/+60°C	-20°C/+60°C			-20°C/+60°C		
Produttore Manufacturer Hersteller	ISO VG 150	ISO VG 220	ISO VG 320	ISO VG 150	ISO VG 220	ISO VG 320	ISO VG 150	ISO VG 220	ISO VG 320
AGIP	Blasia 150	Blasia 220	Blasia 320	-	Blasia SX 220	Blasia SX 320	Blasia S 150	Blasia S 220	Blasia S 320
BP	Energol GR-XP 150	Energol GR-XP 220	Energol GR-XP 320	Enersyn EPX 150	Enersyn EPX 220	Enersyn EPX 320	Enersyn SG 150	Enersyn SG-XP 220	Enersyn SG-XP 320
CASTROL	Alpha SP 150	Alpha SP 220	Alpha SP 320	Alphasyn EP 150	Alphasyn EP 220	Alphasyn EP 320	Alphasyn PG 150	Alphasyn PG 220	Alphasyn PG 320
CHEVRON	Ultra Gear 150	Ultra Gear 220	Ultra Gear 320	Tegra Synthetic Gear 150	Tegra Synthetic Gear 220	Tegra Synthetic Gear 320	HiPerSYN 150	HiPerSYN 220	HiPerSYN 320
KLÜBER	Klüberoil GEM 1-150	Klüberoil GEM 1-220	Klüberoil GEM 1-320	Klübersynth EG 4-150	Klübersynth EG 4-220	Klübersynth EG 4-320	Klübersynth GH 6-150	Klübersynth GH 6-220	Klübersynth GH 6-320
MOBIL	Mobilgear XMP 150	Mobilgear XMP 220	Mobilgear XMP 320	Mobilgear SHC Gear 150	Mobilgear SHC Gear 220	Mobilgear SHC Gear 320	Glygoyle 150	Glygoyle 220	Glygoyle 320
MOLIKOTE	L-0115	L-0122	L-0132	L-1115	L-1122	L-1132	-	-	-
SHELL	Omala S2 G 150	Omala S2 G 220	Omala S2 G 320	Omala S4 GX 150	Omala S4 GX 220	Omala S4 GX 320	Omala S4 WE 150	Omala S4 WE 220	Omala S4 WE 320
TEXACO	Meropa 150	Meropa 220	Meropa 320	Pinnacle EP 150	Pinnacle EP 220	Pinnacle EP 320	-	Synlube CLP 220	Synlube CLP 320
TOTAL	Carter EP 150	Carter EP 220	Carter EP 320	Carter SH 150	Carter SH 220	Carter SH 320	Carter SY 150	Carter SY 220	Carter SY 320
TRIBOL	1100/150	1100/220	1100/320	1510/150	1510/220	1510/320	800/150	800/220	800/320

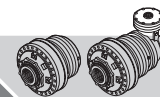

6.3 Encrassement

Durant les premières heures de fonctionnement des réducteurs, à cause du contact entre les surfaces non rodées, des particules métalliques salissent l'huile. La présence de ces particules a un effet négatif sur la durée de vie des engrenages et des roulements.

Pour réduire la présence de particules métalliques dans l'huile, il est conseillé de:

- changer l'huile de les réducteurs et de les freins après les 100 premières heures de fonctionnement et par la suite, toutes les 1500-2000 heures ou tous les 12 mois;
- nettoyer périodiquement les bouchons magnétiques;
- filtrer l'huile, à l'aide d'un système auxiliaire de refroidissement.

Les types de lubrifiant conseillés sont indiqués sur le tableau suivant:

6.3 Contaminación

Durante las primeras horas de funcionamiento de los reductores, debido al contacto entre las superficies no rodadas, se produce una difusión de partículas metálicas en el aceite. La presencia de estas partículas tiene un efecto ciertamente negativo sobre la duración de vida de engranajes y cojinetes.

Para reducir la presencia de partículas metálicas en el aceite se aconseja:

- *sustituir el aceite de los reductores y de los frenos al cabo de las primeras 100 horas de funcionamiento y sucesivamente cada 1500-2000 horas o cada 12 meses;*
- *limpiar periódicamente los tapones magnéticos;*
- *filtrar el aceite, mediante un sistema auxiliar de refrigeración.*

Los tipos de lubricante aconsejados se indican en la tabla siguiente:

6.3 Contaminação

Durante as primeiras horas de funcionamento dos redutores, devido ao contato entre as superfícies não rodadas, verifica-se uma difusão de partículas metálicas no óleo. A presença destas partículas tem um efeito certamente negativo na duração de vida das engrenagens e dos rolamentos.

Para reduzir a presença de partículas metálicas no óleo aconselhamos:

- proceder à substituição do óleo dos redutores e os freios depois das primeiras 100 horas de funcionamento e em seguida cada 1500-2000 horas ou cada 12 meses;
- limpar periodicamente os tampões magnéticos;
- efetuar a filtragem do óleo, através de um sistema auxiliar de arrefecimento.

Os tipos de lubrificante aconselhados estão indicados na tabela seguinte:

Lubrifiants pour toute utilisation

Lubricantes para uso general

Lubrificantes para uso geral

Température ambiante Temperatura ambiente Temperatura ambiente	Huiles Minérales Aceites Minerales Óleos Minerais			Huiles Synthétiques Polyalphaoléfine (PAO) Aceites Sintéticos Polialfaolefinas (PAO) Óleos Sintéticos Polialfaolefine (PAO)			Huiles Synthétiques Polyglycoles (PG) Aceites Sintéticos Poliglicol (PG) Óleos Sintéticos Poliglicóis (PG)		
	-10°C/+30°C	+10°C/+45°C	+30°C/+60°C	-20°C/+60°C			-20°C/+60°C		
Producteur Productor Produtor	ISO VG 150	ISO VG 220	ISO VG 320	ISO VG 150	ISO VG 220	ISO VG 320	ISO VG 150	ISO VG 220	ISO VG 320
AGIP	Blasia 150	Blasia 220	Blasia 320	-	Blasia SX 220	Blasia SX 320	Blasia S 150	Blasia S 220	Blasia S 320
BP	Energol GR-XP 150	Energol GR-XP 220	Energol GR-XP 320	Enersyn EPX 150	Enersyn EPX 220	Enersyn EPX 320	Enersyn SG 150	Enersyn SG-XP 220	Enersyn SG-XP 320
CASTROL	Alpha SP 150	Alpha SP 220	Alpha SP 320	Alphasyn EP 150	Alphasyn EP 220	Alphasyn EP 320	Alphasyn PG 150	Alphasyn PG 220	Alphasyn PG 320
CHEVRON	Ultra Gear 150	Ultra Gear 220	Ultra Gear 320	Tegra Synthetic Gear 150	Tegra Synthetic Gear 220	Tegra Synthetic Gear 320	HiPerSYN 150	HiPerSYN 220	HiPerSYN 320
KLÜBER	Klüberoil GEM 1-150	Klüberoil GEM 1-220	Klüberoil GEM 1-320	Klübersynth EG 4-150	Klübersynth EG 4-220	Klübersynth EG 4-320	Klübersynth GH 6-150	Klübersynth GH 6-220	Klübersynth GH 6-320
MOBIL	Mobilgear XMP 150	Mobilgear XMP 220	Mobilgear XMP 320	Mobilgear SHC Gear 150	Mobilgear SHC Gear 220	Mobilgear SHC Gear 320	Glygoyle 150	Glygoyle 220	Glygoyle 320
MOLIKOTE	L-0115	L-0122	L-0132	L-1115	L-1122	L-1132	-	-	-
SHELL	Omala S2 G 150	Omala S2 G 220	Omala S2 G 320	Omala S4 GX 150	Omala S4 GX 220	Omala S4 GX 320	Omala S4 WE 150	Omala S4 WE 220	Omala S4 WE 320
TEXACO	Meropa 150	Meropa 220	Meropa 320	Pinnacle EP 150	Pinnacle EP 220	Pinnacle EP 320	-	Synlube CLP 220	Synlube CLP 320
TOTAL	Carter EP 150	Carter EP 220	Carter EP 320	Carter SH 150	Carter SH 220	Carter SH 320	Carter SY 150	Carter SY 220	Carter SY 320
TRIBOL	1100/150	1100/220	1100/320	1510/150	1510/220	1510/320	800/150	800/220	800/320

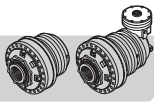

Produttore Manufacturer Hersteller	Oli Idrraulici Hydraulic oils Hydrauliköle			Oli per ingranaggi Gear oils Getriebeöle		
	ISO VG 32	ISO VG 46	ISO VG 68	ISO VG 150	ISO VG 220	ISO VG 320
AGIP	Rocol Foodlube Hi Power 32	-	-	Rocol Foodlube Hi-Torque 150	-	Rocol Foodlube Hi-Torque 320
BP	Enerpar M 32	Enerpar M 46	Enerpar M 68	-	-	-
KLÜBER	Summit Hysyn FG 32	Summit Hysyn FG 46	Summit Hysyn FG 68	Klüberoil 4 UH1 N 150	Klüberoil 4 UH1 N 220	Klüberoil 4 UH1 N 320
MOBIL	DTE FM 32	DTE FM 46	DTE FM 68	DTE FM 150	DTE FM 220	DTE FM 320
SHELL	Cassida Fluid HF 32	Cassida Fluid HF 46	Cassida Fluid HF 68	Cassida Fluid GL 150	Cassida Fluid GL 220	Cassida Fluid GL 320
TEXACO	Cygnus Hydraulic Oil 32	Cygnus Hydraulic Oil 46	Cygnus Hydraulic Oil 68	Cygnus Gear PAO 150	Cygnus Gear PAO 220	-
TOTAL	Nevastane AW 32	Nevastane AW 46	Nevastane AW 68	Nevastane SL 150	Nevastane SL 220	Nevastane SL 320
TRIBOL	Food Proof 1840/32	Food Proof 1840/ 46	Food Proof 1840/68	-	Food Proof 1810/220	Food Proof 1810/320

Nel caso di impiego di altri lubrificanti sintetici, verificarne la compatibilità con le tenute paraolio in NBR presenti nel riduttore.

If other synthetic lubricants are used always check their compatibility with the NBR oil seals used in the reduction gear.

Bei Verwendung synthetischer Schmiermittel muss die Kompatibilität mit den im Planetengetriebe montierten Öldichtungen aus NBR geprüft werden.



Non mescolare lubrificanti sintetici di tipo differente.

Do not mix different kinds of synthetic lubricant together.

Unterschiedliche Typen von synthetischen Schmiermitteln dürfen nicht gemischt werden.

Se le condizioni di esercizio del riduttore prevedono prolungati periodi di funzionamento tali da produrre una elevata temperatura dell'olio (>60°C) si consiglia l'utilizzo di olio sintetico, per garantire una minore usura dei componenti ed aumentare gli intervalli di sostituzione.

If the operating conditions of the reduction gear entail prolonged periods of operation such to cause the oil temperature to rise considerably (>60°C) we suggest using a synthetic oil to guarantee less wear of the components and to prolong the intervals between replacing them.

Wenn die Betriebsbedingungen vom Planetengetriebe längere Betriebszeiten vorsehen, die zu hohen Öltemperaturen führen (>60°C), wird zur Verwendung von synthetischem Öl geraten, das für einen geringeren Verschleiß der Teile und größere Abstände zwischen den Ölwechseln garantiert.

La temperatura massima del lubrificante all'interno del riduttore non deve oltrepassare i 90°C.

Maximum temperature of the lubricant inside the reduction gear must not go above 90°C.

Die Temperatur vom Schmiermittel im Planetengetriebe darf 90°C nicht übersteigen.

6.4 Posizioni di montaggio e disposizione dei tappi

6.4 Mounting positions and plugs position

6.4 Montageposition und Anordnung der Deckel

Nelle figure seguenti sono mostrate le possibili posizioni di montaggio, la cui sigla deve essere specificata in fase di ordine del riduttore.

You can see the possible mounting positions in the figures below. The relative initial must be specified when ordering the reduction gear.

Die Abbildungen unten zeigen die möglichen Montagepositionen, deren Kürzel bei der Bestellung vom Planetengetriebe angegeben werden muss.

Inoltre sono indicati la disposizione e la tipologia dei tappi ed il livello minimo di lubrificante, come da legenda.

The layout and type of plugs as well as the minimum lubricant level are also indicated, as per the legend.

Außerdem sind die Anordnung und der Typ der Deckel sowie der Mindestölstand angegeben (siehe Legende).

Attenzione:

Per servizi continuativi (24 h) consigliamo di utilizzare tappi di sfiato con il labirinto e filtro sinterizzato assieme ad una colonnetta.

Attention!

For continuous duty (24h) uses venting plug with labyrinth and filter and a column.

Achtung!

Bei Dauerbetrieb ist es besser auf Säule gebauten Belüftungspfropfen mit synthetischem Filter und Labyrinth einzusetzen.

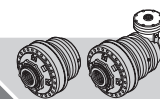

Producteur Productor Produtor	Huiles hydrauliques Aceites hidráulicos Óleos hidráulicos			Huiles pour engrenages Aceites para engranajes Óleos para engranagens		
	ISO VG 32	ISO VG 46	ISO VG 68	ISO VG 150	ISO VG 220	ISO VG 320
AGIP	Rocol Foodlube Hi Power 32	-	-	Rocol Foodlube Hi-Torque 150	-	Rocol Foodlube Hi-Torque 320
BP	Enerpar M 32	Enerpar M 46	Enerpar M 68	-	-	-
KLÜBER	Summit Hysyn FG 32	Summit Hysyn FG 46	Summit Hysyn FG 68	Klüberoil 4 UH1 N 150	Klüberoil 4 UH1 N 220	Klüberoil 4 UH1 N 320
MOBIL	DTE FM 32	DTE FM 46	DTE FM 68	DTE FM 150	DTE FM 220	DTE FM 320
SHELL	Cassida Fluid HF 32	Cassida Fluid HF 46	Cassida Fluid HF 68	Cassida Fluid GL 150	Cassida Fluid GL 220	Cassida Fluid GL 320
TEXACO	Cygnus Hydraulic Oil 32	Cygnus Hydraulic Oil 32	Cygnus Hydraulic Oil 32	Cygnus Gear PAO 150	Cygnus Gear PAO 220	-
TOTAL	Nevastane AW 32	Nevastane AW 46	Nevastane AW 68	Nevastane SL 150	Nevastane SL 220	Nevastane SL 320
TRIBOL	Food Proof 1840/32	Food Proof 1840/ 46	Food Proof 1840/68	-	Food Proof 1810/220	Food Proof 1810/320

Si on utilise d'autres lubrifiants synthétiques, vérifier leur compatibilité avec les joints étanches à l'huile en NBR présents dans le réducteur.

En caso de utilización de otros lubricantes sintéticos, comprobar la compatibilidad con los sellos de aceite de NBR presentes en el reductor.

No caso de emprego de outros lubrificantes sintéticos, verificar a compatibilidade com as vedações do óleo em NBR presentes no redutor.



Ne pas mélanger des lubrifiants synthétiques de types différents.

No mezclar lubricantes sintéticos de diferentes tipos.

Não misturar lubrificantes sintéticos de tipo diferente.

Si les conditions de service du réducteur prévoient des périodes de fonctionnement prolongées entraînant une température de l'huile élevée (>60°C) il est conseillé d'utiliser de l'huile synthétique, pour que les composants s'usent moins rapidement et par conséquent distancier les substitutions qui s'avèrent tôt ou tard nécessaires.

Si las condiciones de funcionamiento del reductor prevén largos periodos de funcionamiento tales que se produzcan altas temperaturas del aceite (>60°C), se aconseja utilizar aceite sintético, para garantizar un menor desgaste de los componentes y aumentar los intervalos de sustitución.

Se as condições de exercício do redutor prevêem longos períodos de funcionamento que possam produzir uma elevada temperatura do óleo (> 60 °C) aconselhamos o uso de óleo sintético, para garantir um menor desgaste dos componentes e aumentar os intervalos de substituição.

La température maximum du lubrifiant dans le réducteur ne doit pas dépasser 90°C.

La temperatura máxima del lubricante dentro del reductor no debe superar los 90°C.

A temperatura máxima do lubrificante no interior do redutor não deve ultrapassar os 90°C.

6.4 Positions de montage et disposition des bouchons

Les figures ci-dessous montrent les possibilités de positionnement de montage, dont il faut indiquer le sigle au moment de la commande du réducteur.

La disposition et la typologie des bouchons et le niveau minimum de lubrifiant sont aussi indiqués, comme le montre la légende.

Attention:

En cas de services continus (de 24 heures) nous vous conseillons d'utiliser des bouchons d'évent avec le labyrinthe et le filtre fritté ensemble à une colonnette.

6.4 Posiciones de montaje y ubicación de los tapones

En las figuras siguientes se muestran las posibles posiciones de montaje, cuya sigla se debe especificar en el pedido del reductor.

Además se indican la ubicación y el tipo de los tapones y el nivel mínimo de lubricante, conforme a las explicaciones.

¡Atención!

Para servicios continuados (24h) aconsejamos utilizar tapones con respiradero con el laberinto y el filtro sinterizado junto con un racor.

6.4 Posições de montagem e disposição dos tampões

Nas figuras seguintes estão ilustradas as possíveis posições de montagem, cuja referência deve ser especificada na fase de encomenda do redutor.

Além disso, também estão indicados a disposição, o tipo de tampões e o nível mínimo de lubrificante, como ilustrado na legenda.

Atenção!

Para os serviços em curso (24 horas) recomendamos o uso de tampões ventilados labirinto com filtro sinterizado e com uma coluna.

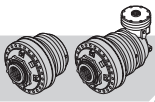

- ① Carico e sfiato
Filling up and venting
Füllen und Entlüften
- ② Livello
Level
Ölstand
- ③ Scarico
Drainage
Ablass
- ④ Sfiato durante il carico
Venting while filling up
Entlüften beim Füllen
- Livello minimo
Minimum level
Mindestölstand

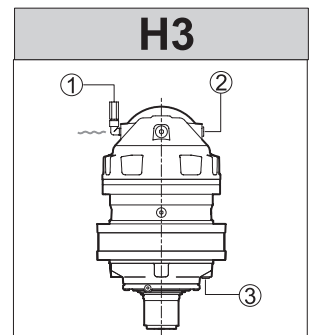
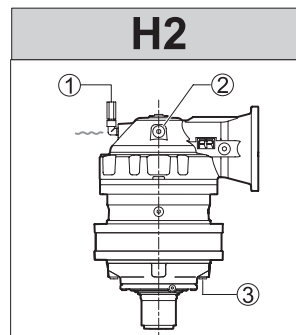
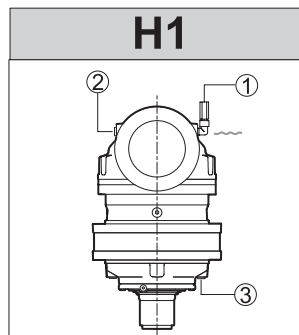
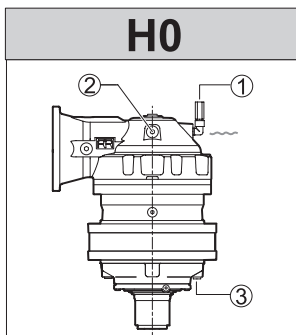
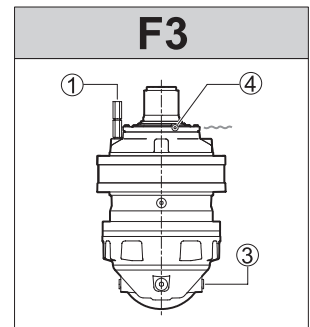
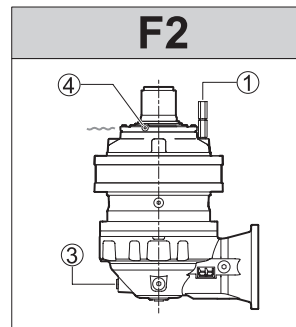
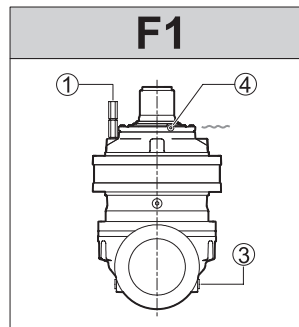
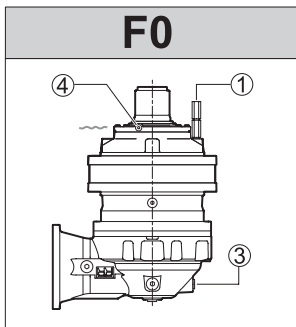
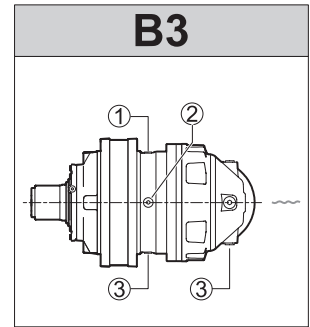
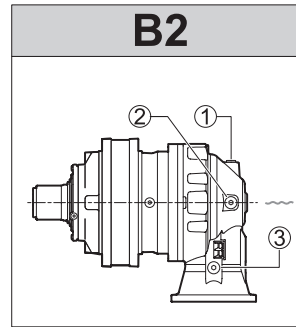
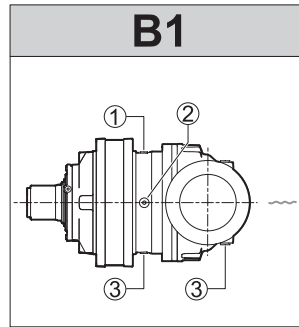
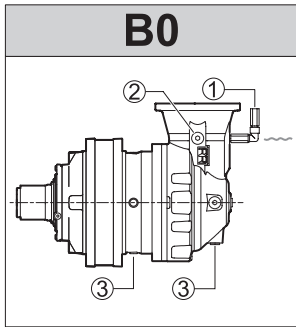
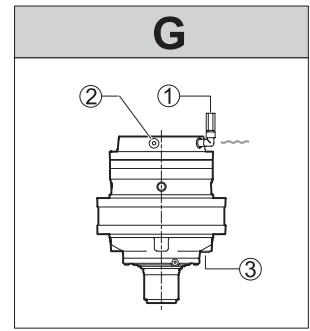
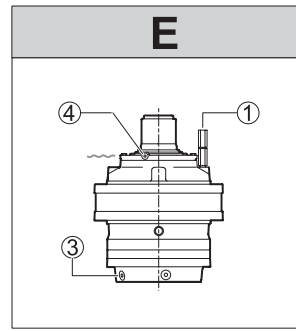
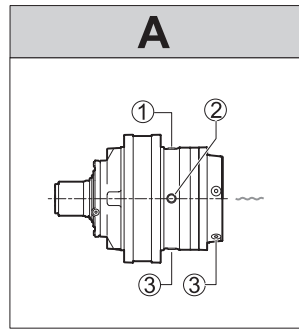

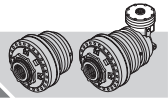

- ① Nourissage et évent
Carga y purga
Carga e resfolgo
- ② Niveau
Nivel
Nivel
- ③ Vidange
Descarga
Esvazamiento
- ④ Event pendant le nourissage
Purga durante la carga
Resfolgo durante a carga
- Niveau minimum
Nivel mínimo
Nivel mínimo

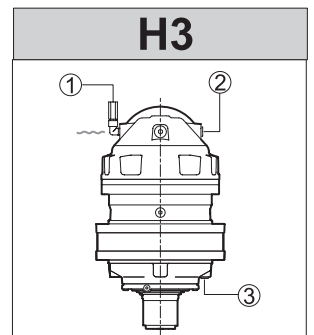
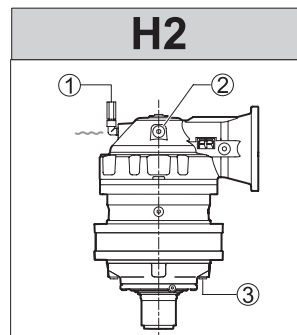
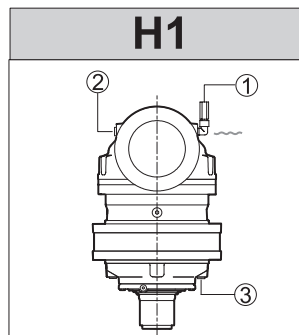
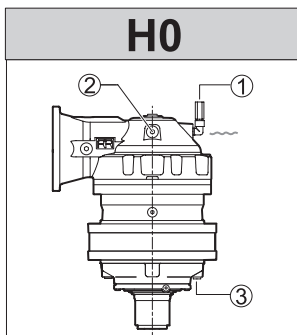
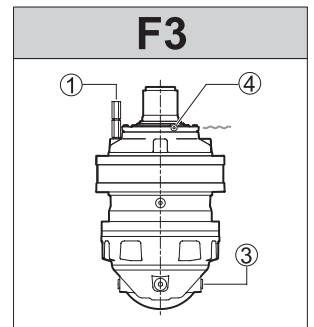
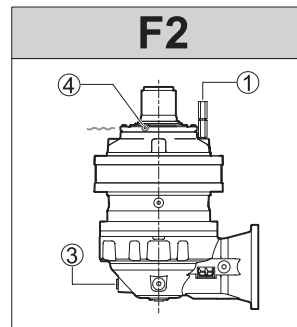
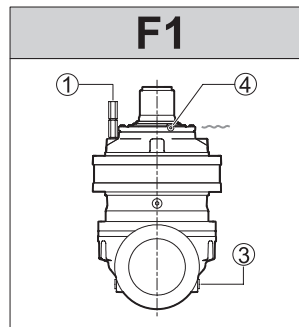
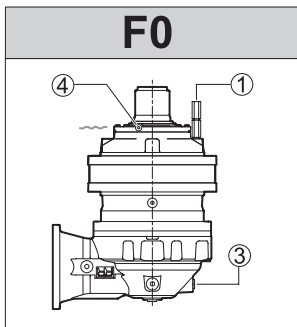
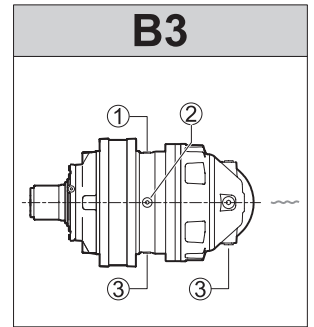
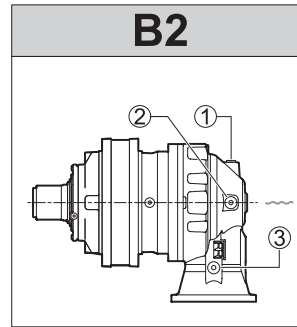
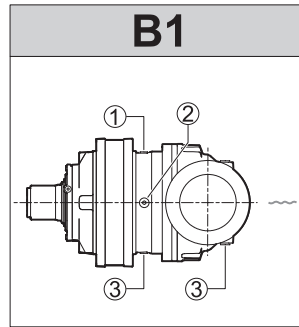
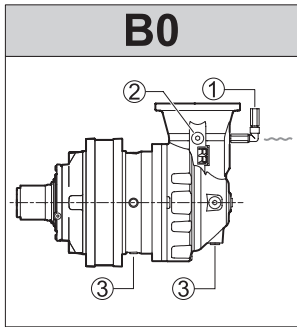
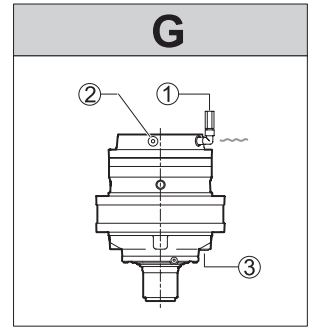
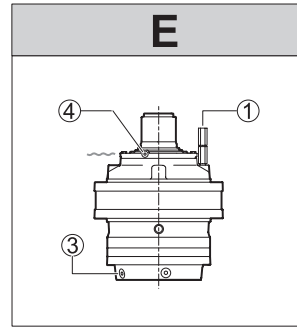
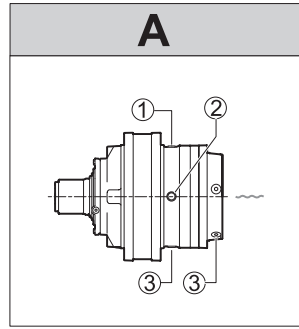

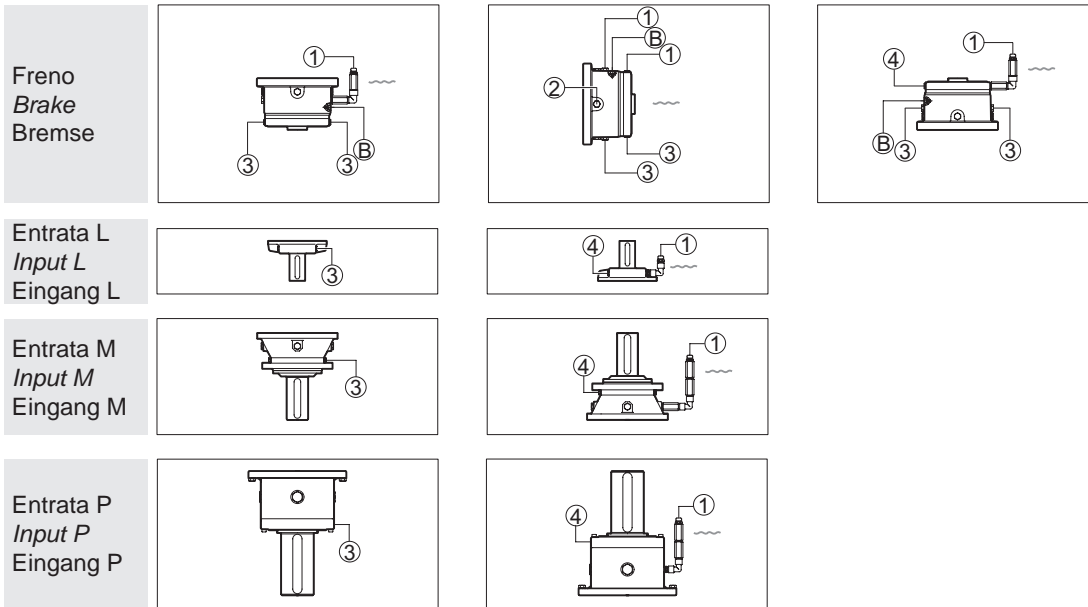
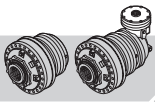

- ① Carico e sfiato
Filling up and venting
Füllen und Entlüften
- ② Livello
Level
Ölstand
- ③ Scarico
Drainage
Ablass
- ④ Sfiato durante il carico
Venting while filling up
Entlüften beim Füllen
- Ⓑ Comando apertura freno
Brake opening control
Steuerung Bremsenöffnung
- Livello minimo
Minimum level
Mindestölstand

6.5 Riempimento

Per le posizioni di montaggio A, B1, B2 e B3 il riempimento va effettuato fino alla mezzieria del riduttore; il corretto livello del lubrificante può essere verificato mediante gli appositi tappi di livello, indicati con (2) nella figura precedente.

Per le posizioni di montaggio E, G, B0, F0, F1, F2, F3, H0, H1, H2 e H3, è necessario effettuare il completo riempimento, in modo da consentire la corretta lubrificazione dei componenti posti nella parte più alta del riduttore. In questo caso durante il riempimento occorre rimuovere almeno uno dei tappi posti nella parte più alta del riduttore, indicati con (4) nella figura precedente, in modo da evitare la formazione di bolle d'aria.

6.5 Filling up

For the assembly positions A, B1, B2 and B3 fill up to the halfway point of the reduction gear; the right level of the lubricant can be checked with the level plugs, indicated with (2) in the previous figure.

For the assembly positions E, G, B0, F0, F1, F2, F3, H0, H1, H2 and H3, they have to be filled right up to the top to allow correct lubrication of the components situated at the upper most part of the reduction gear. In this case, when filling up, you have to remove at least one of the plugs from the upper most part of the reduction gear, indicated with (4) in the previous figure, so as to prevent air bubbles forming.

6.5 Einfüllen vom Öl

Bei den Montagepositionen A, B1, B2 und B3 erfolgt das Einfüllen bis zur Mittellinie vom Planetengetriebe. Der korrekte Ölstand kann über die dafür vorgesehenen Ölstandsdeckel kontrolliert werden (siehe Abbildung oben (2)).

Bei den Montagepositionen E, G, B0, F0, F1, F2, F3, H0, H1, H2 und H3 ist eine komplette Füllung erforderlich, um die korrekte Schmierung der Teile an der höchsten Stelle im Planetengetriebe zur garantieren. In diesem Fall muss beim Einfüllen mindestens einer der Deckel oben (Abbildung oben (4)) abgenommen werden, damit sich keine Luftblasen bilden.

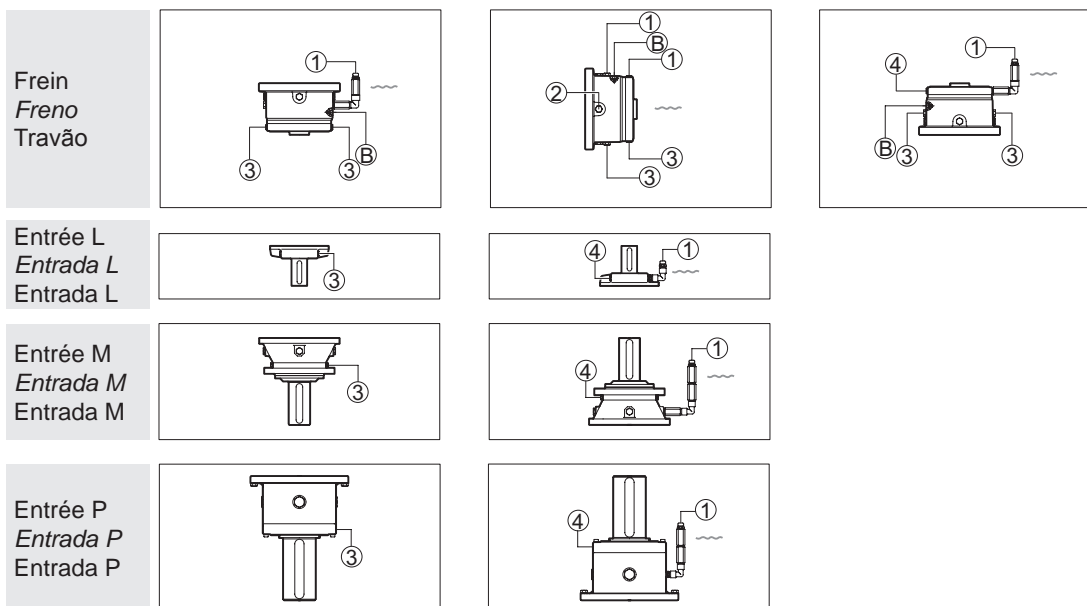
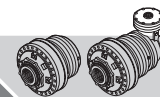

- ① Nourissage et évent
Carga y purga
Carga e resfolgo
- ② Niveau
Nivel
Nível
- ③ Vidange
Descarga
Esvazamiento
- ④ Event pendant le nourissage
Purga durante la carga
Resfolgo durante a carga
- Ⓑ Commande d'ouverture du frein
Mando apertura freno
Comando abertura travão
- Niveau minimum
Nivel mínimo
Nível mínimo

6.5 Nourissage

Pour les positions de montage A, B1, B2 et B3 le nourissage doit être fait jusqu'à la ligne médiane du réducteur; le niveau correct de lubrifiant peut être vérifié à l'aide de jauges, indiquées par un (2) sur la figure précédente.

Pour les positions de montage E, G, B0, F0, F1, F2, F3, H0, H1, H2 et H3, il est nécessaire d'effectuer un nourissage complet, pour permettre la bonne lubrification des composants se trouvant dans la partie la plus haute du réducteur. Dans ce cas, pendant le nourissage, enlever au moins l'un des bouchons se trouvant dans la partie la plus haute du réducteur, indiqués par un (4) sur la figure précédente, de manière à éviter la formation de bulles d'air.

6.5 Llenado

Para las posiciones de montaje A, B1, B2 y B3 el llenado se debe efectuar hasta la línea mediana del reductor; el nivel correcto del lubricante se puede comprobar a través de los correspondientes tapones de nivel, indicados con (2) en la figura precedente.

Para las posiciones de montaje E, G, B0, F0, F1, F2, F3, H0, H1, H2 y H3, es necesario efectuar un llenado completo, para consentir la lubricación correcta de los componentes situados en la parte más alta del reductor. En este caso, durante el llenado es preciso quitar por lo menos uno de los tapones situados en la parte más alta del reductor, indicados con (4) en la figura precedente, a fin de evitar que se formen burbujas de aire.

6.5 Enchimento

Para as posições de montagem A, B1, B2 e B3 o enchimento deve ser efetuado até metade do redutor; o correto nível do lubrificante pode ser verificado através dos respetivos tampões de nível, indicados como (2) na figura precedente.

Para as posições de montagem E, G, B0, F0, F1, F2, F3, H0, H1, H2 e H3, é necessário efetuar o enchimento completo, de modo a consentir a correta lubrificação dos componentes situados na parte mais elevada do redutor. Neste caso durante o enchimento é necessário retirar pelo menos um dos tampões situados na parte mais elevada do redutor, indicados com (4) na figura precedente, de modo a evitar a formação de bolhas de ar.

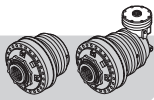

Poiché il lubrificante aumenta il suo volume al crescere della temperatura, quando il riduttore lavora in condizioni di pieno riempimento è necessario predisporre un serbatoio che permetta l'espansione dell'olio e riduca il rischio di pressioni elevate all'interno del riduttore stesso.

Per agevolare l'operazione di riempimento e allo stesso tempo consentire l'espansione dell'olio sono disponibili, a richiesta, degli appositi vasi di espansione, di diverse capacità e fornibili anche sotto forma di kit completo. Tali vasi di espansione possono essere collegati al riduttore mediante connessione rigida o mediante tubi flessibili.

Il vaso di espansione deve essere sempre collocato in modo che il livello dell'olio, visualizzabile ad esempio mediante un tubicino trasparente posto in parallelo con il vaso (di serie per alcuni kit), si trovi al di sopra della zona più alta che si vuole lubrificare e quindi dei tappi di sfiato (4).

As the lubricant increases in volume with the rising temperature, when the reduction gear is working in the completely filled conditions it is necessary to have a tank that allows the oil to expand and thus reduce the risk of high pressures being created inside the reduction gear itself.

To facilitate filling up and, at the same time, allow the oil to expand, expansion tanks are available on request with different capacities and supplied in complete kits. These expansion tanks can be connected to the reduction gear with a rigid connection or flexible pipes.

The expansion tank must always be placed so the level of oil, which can be seen by means of a small transparent tube placed in parallel with the tank for instance (standard in some kits), is above the highest point you wish to lubricate and, hence, above the venting plugs (4).

Da das Schmiermittel mit steigender Temperatur an Volumen gewinnt, muss ein Behälter bereitgestellt werden, der die Ölausdehnung erlaubt und das Risiko hoher Drücke im Planetengetriebe verhindert, wenn mit voller Füllung gearbeitet wird.

Um das Einfüllen zu erleichtern und die Ölausdehnung zu ermöglichen, sind auf Wunsch entsprechende Ausdehnungsgefäße mit unterschiedlichem Fassungsvermögen lieferbar, die auch als kompletter Kit erhältlich sind. Diese Ausdehnungsgefäße können über steife Leitungen oder Schläuche an das Planetengetriebe angeschlossen werden.

Das Ausdehnungsgefäß muss so positioniert sein, dass sich der Ölstand, der zum Beispiel über eine durchsichtige Ölstandsanzeige parallel zum Gefäß (serienmäßig bei einigen Kits) angezeigt wird, oberhalb der höchsten Stelle befindet, die geschmiert werden soll, und damit oberhalb der Entlüftungsdeckel (4).

- ① Carico e sfiato
Filling up and venting
Füllen und Entlüften
- ④ Sfiato durante il carico
Venting while filling up
Entlüften beim Füllen
- Livello minimo
Minimum level
Mindestölstand

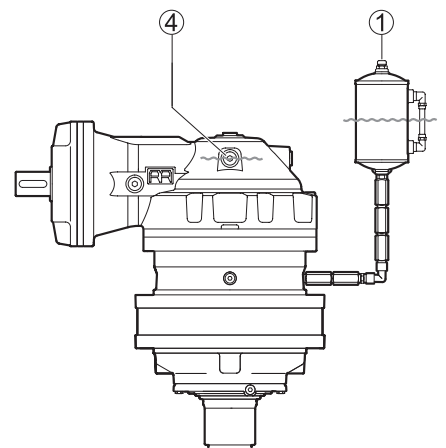
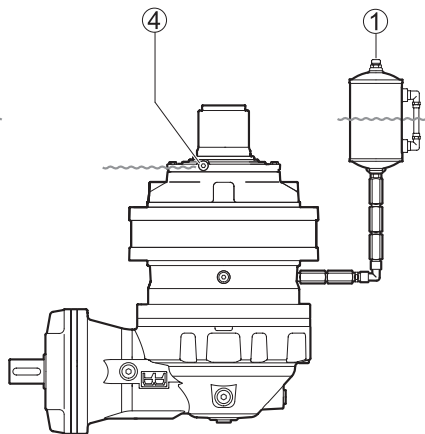
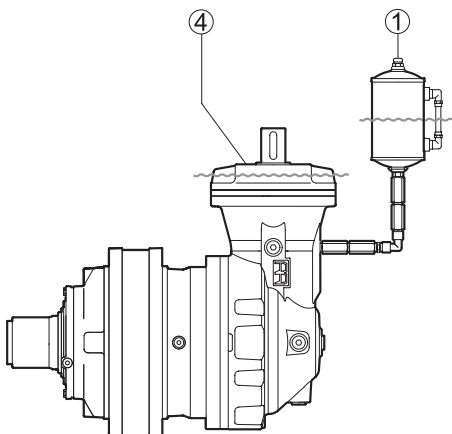
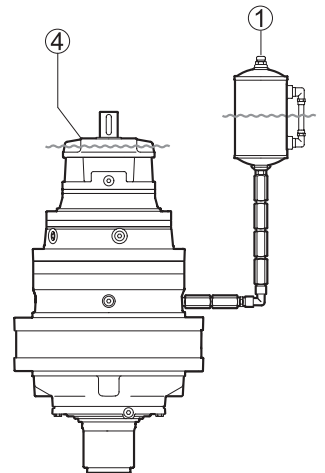
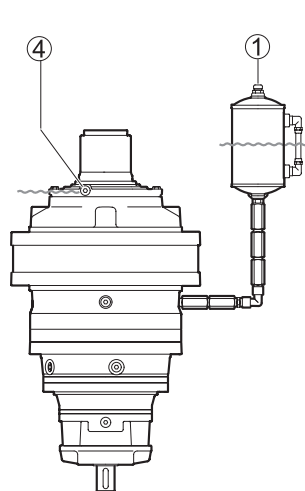

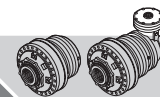

Le lubrifiant augmentant son volume si la température monte, quand le réducteur fonctionne dans des conditions de nourrissage complet, il faut prévoir un réservoir permettant l'expansion de l'huile et la réduction du risque de pressions élevées dans le réducteur.

Pour faciliter l'opération de nourrissage et permettre l'expansion de l'huile, il existe, en option, des vases d'expansion, de différentes capacités et livrables aussi sous forme de kit complet. Ces vases d'expansion peuvent être raccordés au réducteur par des raccords rigides ou des tubes flexibles.

Le vase d'expansion doit toujours être positionné de manière que le niveau de l'huile, qu'on peut contrôler par exemple grâce à un petit tube transparent se trouvant parallèlement au vase (certains kits en sont déjà équipés dès leur sortie d'usine), soit dans la zone la plus haute qu'on veut lubrifier et par conséquent au-dessus des événements (4).

Puesto que el lubricante aumenta su volumen al aumentar la temperatura, cuando el reductor trabaja en condiciones de completo llenado es necesario predisponer un depósito que permita la expansión del aceite y reduzca el riesgo de altas presiones dentro del propio reductor.

Para facilitar la operación de llenado y al mismo tiempo consentir la expansión del aceite, hay disponibles, bajo pedido, unos idóneos vasos de expansión, con diferentes capacidades y suministrables también en forma de kit completo. Dichos vasos de expansión se pueden conectar con el reductor mediante conexión rígida o mediante mangueras flexibles.

El vaso de expansión debe estar situado siempre de manera que el nivel del aceite, visualizable por ejemplo a través de un tubito transparente puesto en paralelo con el vaso (de serie con algunos kits), esté por encima de la zona más alta que se desea lubricar y por lo tanto de los tapones purgadores (4).

Dado que o lubrificante aumenta o seu volume ao aumentar da temperatura, quando o reductor trabalha em condições de enchimento completo é necessário predispor um depósito que consinta a expansão do óleo e reduza o risco de pressões elevadas no interior do próprio reductor.

Para facilitar a operação de enchimento e ao mesmo tempo consentir a expansão do óleo são disponíveis, a pedido, alguns depósitos de expansão, de vária capacidade e que também são fornecidos sob forma de kit completo. Estes vasos de expansão podem ser ligados ao reductor mediante ligação rígida ou mediante tubos flexíveis.

O vaso de expansão deve ser sempre colocado de modo a que o nível do óleo, visualizável, por exemplo através de um tubinho transparente situado em paralelo com o depósito (de série em alguns kits), se encontre acima da zona mais alta que se deseja lubrificar e portanto dos tampões de resfolgo (4).

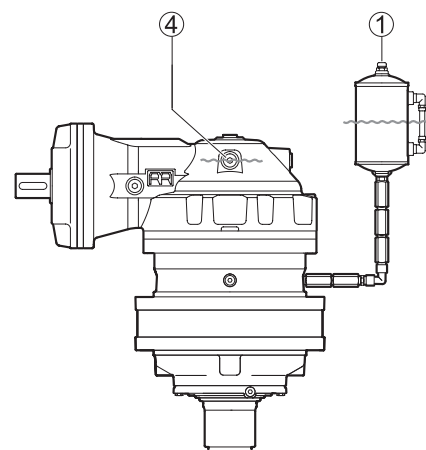
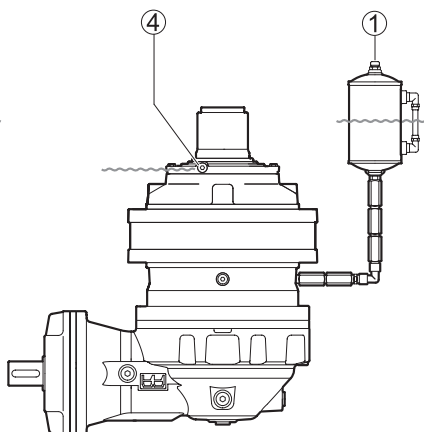
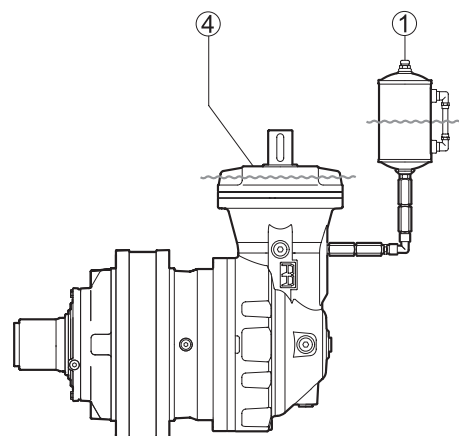
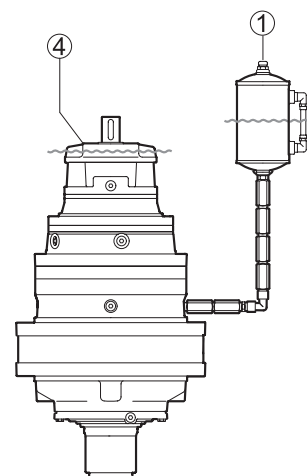
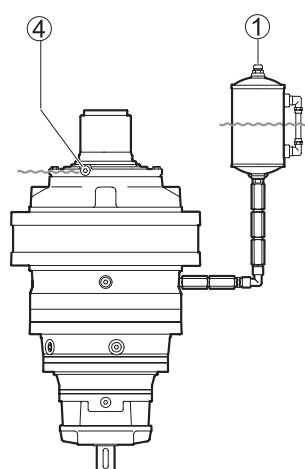
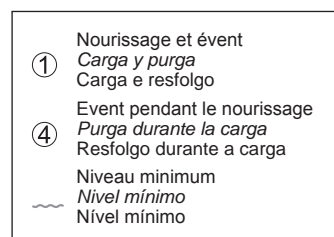

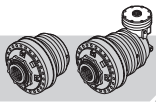

Fare riferimento alla seguente tabella e alla relativa figura per conoscere i codici di vendita e i dati tecnici dei kit serbatoio.

Please refer to the following table and relative figure for the sales codes and technical specifications of the tank kits.

Die Bestellnummern und technischen Daten der Kits für Ausdehnungsgefäße können der Tabelle unten und der dazugehörigen Abbildung entnommen werden.

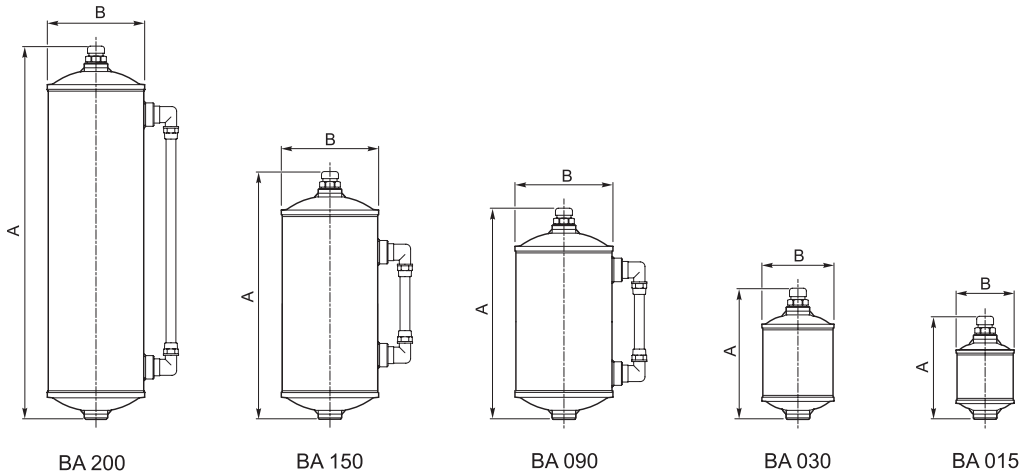

Tipo / Type / Typ	A	B	Capacità / Capacity Fassung-vermögen [l]	Codice / Code / Code	
				Kit completo Code of the complete kit Bestellnr. kompletter	Serbatoio Tank code Behälter
BA 015	110	65	~ 0.15	154-5764	154F1562
BA 030	140	80	~ 0.30	154-5749	154F1563
BA 090	225	104	~ 0.90	154-5733	154F1561
BA 150	265	104	~ 1.50	154F5986	154F5988
BA 200	400	104	~ 2.00	154F5987	154F5989

La scelta del serbatoio va fatta in base al volume di olio espanso V_e ; questo si può determinare nel seguente modo: individuare sul grafico che segue il punto che ha per ascissa la differenza Δt tra la temperatura dell'olio del riduttore e la temperatura ambiente e per ordinata il volume V di olio necessario al riempimento del riduttore. In base alla zona del grafico in cui cade il punto si determina il volume di olio espanso V_e e si dimensiona il serbatoio per un volume doppio rispetto a quello calcolato.

The choice of tank should be based on the volume of expanded oil V_e ; this can be found in the following way: in the following graph, find the point which has Δt difference between the reduction gear's oil temperature and ambient temperature as the abscissa and volume V of oil necessary to fill the reduction gear as the ordinate. On the basis of the area in which the point falls, you find the volume of expanded oil V_e and the tank is sized for double the volume calculated.

Für die Auswahl vom Behälter ist das Volumen vom ausgedehnten Öl V_e entscheidend, das wie folgt ermittelt werden kann: Auf der Grafik den Punkt ermitteln, dessen X-Koordinate die Differenz Δt zwischen der Öltemperatur im Getriebe und der Umgebungstemperatur ist und dessen Y-Koordinate das Volumen V vom Öl, das zum Füllen vom Getriebe erforderlich ist. Anhand des Bereichs auf der Grafik, in den der Punkt fällt, kann das Volumen V_e vom ausgedehnten Öl ermittelt werden. Der Behälter wird dann auf das doppelte Volumen des errechneten Werts ausgelegt.

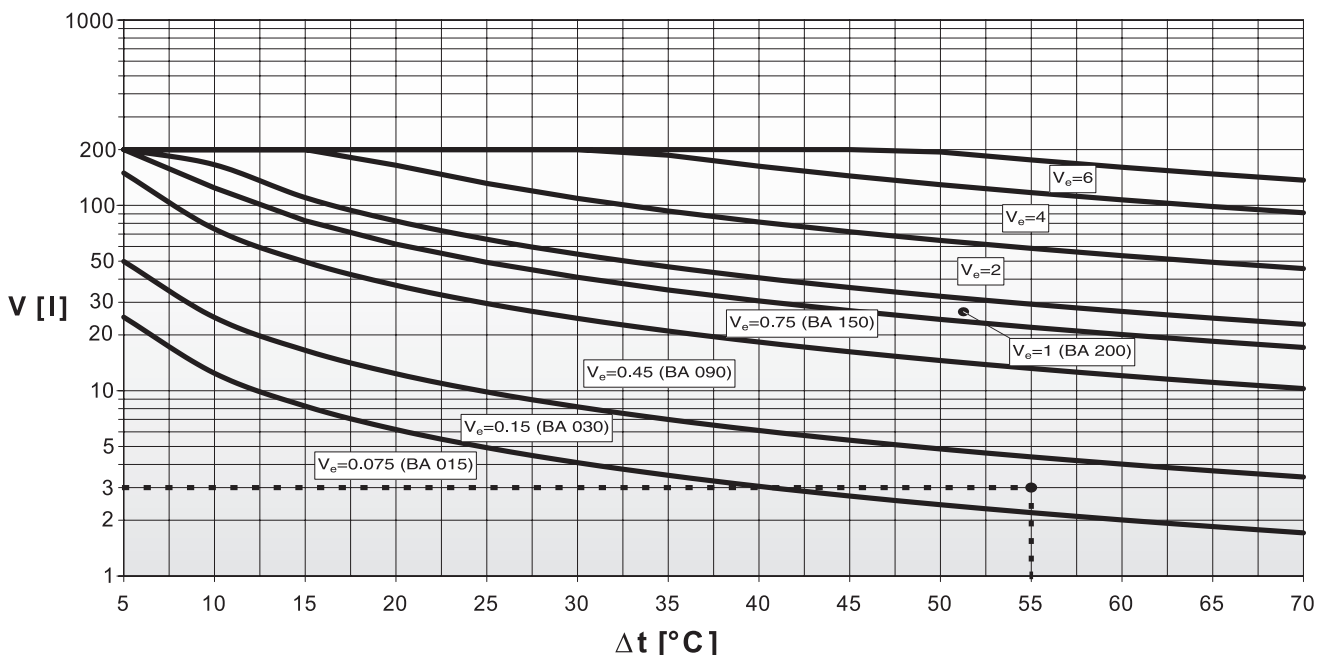

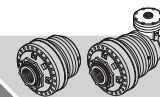

Voir le tableau suivant et la figure correspondante pour connaître les codes de vente et les caractéristiques techniques des kits réservoir.

Hágase referencia a la siguiente tabla y a la correspondiente figura para conocer los códigos de venta y los datos técnicos de los kits depósito.

Consultar a seguinte tabela e a relativa figura para conhecer os códigos de venda e os dados técnicos dos kits depósito.

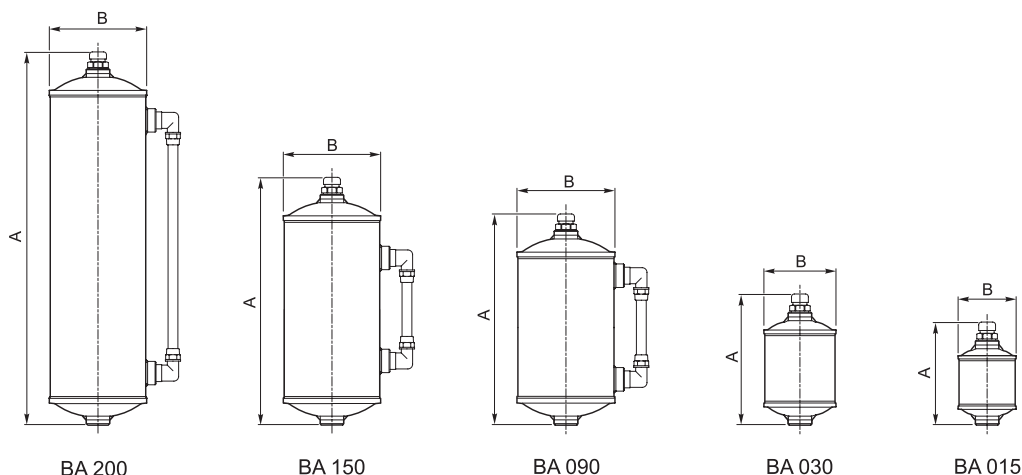

Type / Tipo / Tipo	A	B	Contenance Capacidad Capacidade [l]	Code / Código / Code	
				Kit complet Kit completo Kit completo	Réservoir Depósito Depósito
BA 015	110	65	~ 0.15	154-5764	154F1562
BA 030	140	80	~ 0.30	154-5749	154F1563
BA 090	225	104	~ 0.90	154-5733	154F1561
BA 150	265	104	~ 1.50	154F5986	154F5988
BA 200	400	104	~ 2.00	154F5987	154F5989

Le choix du réservoir se fait en fonction du volume d'huile expansé V_e ; ce volume peut être déterminé de la manière suivante : trouver sur le graphique ci-dessous le point qui a pour abscisse la différence Δt entre la température de l'huile du réducteur et la température ambiante et pour ordonnée le volume V d'huile nécessaire au nourrissage du réducteur. En fonction de la zone du graphique où tombe le point, on détermine le volume d'huile expansé V_e et on choisit les dimensions du réservoir sur la base d'un volume double par rapport au volume calculé.

El depósito se debe seleccionar sobre la base del volumen de aceite expandido V_e ; lo que se puede determinar de la siguiente manera: Individuar, en el gráfico siguiente, el punto que tiene por abscisa la diferencia Δt entre la temperatura del aceite del reductor y la temperatura ambiente y por ordenada el volumen V de aceite necesario para llenar el reductor. En base a la zona del gráfico en la cual cae el punto, se determina el volumen de aceite expandido V_e y se dimensiona el depósito para un volumen doble con respecto al calculado.

A escolha do depósito deve ser feita segundo o volume de óleo expandido V_e ; podendo ser determinado no seguinte modo: identificar no gráfico que segue o ponto que tem por abscissa a diferença Δt entre a temperatura do óleo do redutor e a temperatura ambiente e por ordenada o volume V de óleo necessário para encher o redutor. Segundo a zona do gráfico em que se encontra o ponto, determina-se o volume de óleo expandido V_e e dimensiona-se o depósito para um volume duplo respeito àquele calculado.

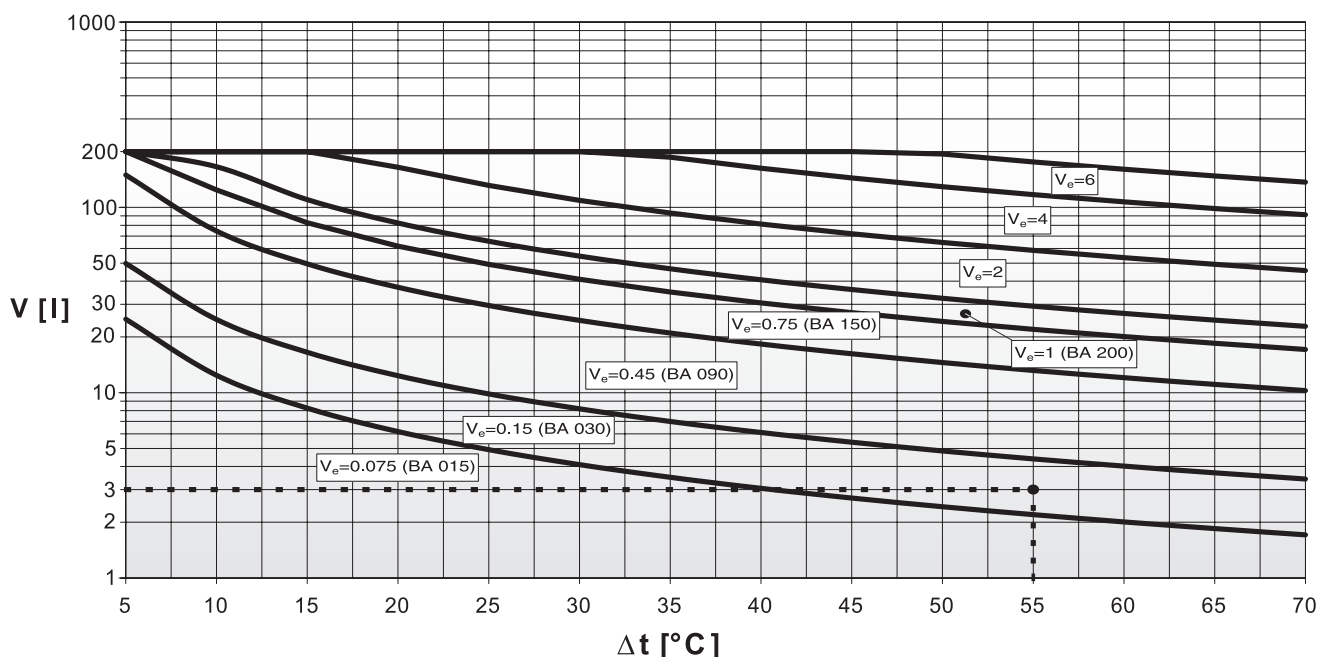

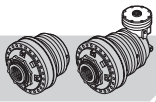

Esempio

Si consideri un riduttore con capacità olio di 3 litri alla temperatura di esercizio di 80°C, con temperatura ambiente di 25°C.

Individuando sul grafico il punto di ascissa $\Delta t = 80-25 = 55^\circ\text{C}$ ed ordinata $V = 3$ litri, questo appartiene alla zona con volume espanso $V_e = 0,15$ litri. Il serbatoio consigliato dovrà avere un volume doppio rispetto a V_e cioè 0,30 litri e dunque il serbatoio idoneo è il BA 030.

Example

Consider a reduction gear with an oil capacity of 3 litres at an operating temperature of 80°C and with an ambient temperature of 25°C.

Finding the abscissa $\Delta t = 80-25 = 55^\circ\text{C}$ and ordinate $V = 3$ litres point on the graph, it belongs to the area with an expanded volume of $V_e = 0,15$ litres. The tank recommended should have a volume double that of V_e - that is 0.30 litres - so the ideal tank is the BA 030.

Beispiel

Es wird von einem Getriebe mit einem Ölfassungsvermögen von 3 Litern bei Betriebstemperatur 80°C und Umgebungstemperatur 25°C ausgegangen.

Es wird ein Punkt mit der X-Koordinate $\Delta t = 80-25 = 55^\circ\text{C}$ und der Y-Koordinate $V = 3$ ermittelt, der in den Bereich mit ausgedehntem Volumen von $V_e = 0,15$ Liter fällt. Der Behälter sollte das Doppelte von V_e fassen, also 0,30 Liter. Geeignet ist damit der Behälter BA 030.

Nelle pagine seguenti sono indicati i volumi di olio, puramente indicativi, necessari per il riempimento, in funzione della posizione di montaggio.

Per i dati mancanti contattare il Servizio Tecnico Reggiana Riduttori.

On the following pages you will find the volumes of oil, purely indicative, necessary to fill up according to the assembly position.

For any data you cannot find, please contact the Reggiana Riduttori Technical Service.

Auf den folgenden Seiten sind reine Richtwerte für die Ölmengen angegeben, die zum Füllen in der entsprechenden Montageposition erforderlich sind.

Fehlende Werte erhalten Sie beim Technischen Kundendienst von Reggiana Riduttori.

Tipo / Type / Typ	Volume olio Oil volume Ölmenge [l]			Massa Mass Gewicht [kg]
	Posizione / Position / Position			
	A	E	G	

RR2500 L1	MS	3.2	6.3	110
	MC	3.2	6.3	145
	FS	2.9	5.9	100
	MH	3.2	6.3	110
RR2500 L2	MS	3.7	7.4	140
	MC	3.7	7.4	175
	FS	3.5	6.9	130
	MH	3.7	7.4	140
	ZI	-	10.7	310
RR2500 L3	MS	4.4	8.9	150
	MC	4.4	8.9	190
	FS	4.2	8.4	140
	MH	4.4	8.9	150
	ZI	-	12.2	320
RR2500 L4	MS	5.6	11.3	160
	MC	5.6	11.3	195
	FS	5.4	10.8	150
	MH	5.6	11.3	160
	ZI	-	14.6	330
RR3200 L1	MS	4.3	8.6	145
	MC	4.3	8.6	155
	FS	4.1	8.2	125
	MH	4.3	8.6	135
RR3200 L2	MS	4.8	9.6	180
	MC	4.8	9.6	190
	FS	4.6	9.2	160
	MH	4.8	9.6	170
	ZI	-	12.3	330
RR3200 L3	MS	5.7	11.4	200
	MC	5.7	11.4	210
	FS	5.5	11	180
	MH	5.7	11.4	190
	ZI	-	14.1	350
RR3200 L4	MS	7.6	15.1	210
	MC	7.6	15.1	220
	FS	7.4	14.7	190

Tipo / Type / Typ	Volume olio Oil volume Ölmenge [l]				Massa Mass Gewicht [kg]
	Posizione / Position / Position				
	B0	F0 F1 F2 F3	H0 H1 H2 H3	B1 B2 B3	

RR2500 A2(A)	MS	14.7	7.4	195
	MC	14.7	7.4	230
	FS	14.3	7.1	185
	MH	14.7	7.4	195
RR2500 A2(B)	MS	19.3	9.7	205
	MC	19.3	9.7	240
	FS	18.8	9.4	190
	MH	19.3	9.7	200
RR2500 A2(C)	MS	29.6	14.8	315
	MC	29.6	14.8	350
	FS	29.2	14.6	300
	MH	29.6	14.8	310
RR2500 A3	MS	12.1	6	185
	MC	12.1	6	220
	FS	11.6	5.8	170
RR2500 A4	MH	12.1	6	180
	MS	10.3	5.2	170
	MC	10.3	5.2	205
	FS	9.9	4.9	160
RR3200 A2(A)	MH	10.3	5.2	170
	MS	17	8.5	230
	MC	17	8.5	240
	FS	16.6	8.3	210
RR3200 A2(B)	MH	17	8.5	220
	MS	21.6	10.8	240
	MC	21.6	10.8	250
	FS	21.2	10.6	220
RR3200 A2(C)	MH	21.6	10.8	230
	MS	31.9	16.0	345
	MC	31.9	16.0	355
	FS	31.5	15.8	325
RR3200 A3(A)	MH	31.9	16.0	335
	MS	14.3	7.1	230
	MC	14.3	7.1	240
	FS	13.9	6.9	210
	MH	14.3	7.1	220

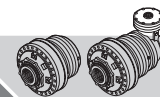
**Exemple**

Si l'on considère un réducteur d'une contenance de 3 litres d'huile à la température de fonctionnement de 80°C, avec une température ambiante de 25°C, et que l'on trouve sur le graphique le point d'abscisse $\Delta t = 80 - 25 = 55^\circ\text{C}$ et d'ordonnée $V = 3$ litres, il appartient à la zone avec volume expansé $V_e = 0,15$ litres. Le réservoir conseillé devra avoir un volume double par rapport à V_e , c'est-à-dire 0,30 litres et par conséquent le réservoir adéquat est le BA 030.

Sur les pages suivantes se trouvent les indications concernant les volumes d'huile, donnés à titre purement indicatif, nécessaires au nourrissage, en fonction de la position de montage. Pour les données manquantes, contacter le service technique Reggiana Riduttori.

Ejemplo

Consideremos un reductor con una capacidad de aceite de 3 litros a la temperatura de funcionamiento de 80°C, con temperatura ambiente de 25°C.

Individuando en el gráfico el punto de abscisa $\Delta t = 80 - 25 = 55^\circ\text{C}$ y ordenada $V = 3$ litros, pertenece a la zona con volumen expandido $V_e = 0,15$ litros. El depósito aconsejado deberá tener un volumen doble con respecto a V_e es decir 0,30 litros y por lo tanto el depósito idóneo será el BA 030.

En las páginas siguientes se indican los volúmenes de aceite, puramente indicativos, necesarios para el llenado, en función de la posición de montaje. Para los datos faltantes cabe contactar con el Servicio Técnico de Reggiana Riduttori.

Exemplo

Considerando um redutor com capacidade de óleo de 3 litros à temperatura de exercício de 80°C, com temperatura ambiente de 25°C.

Identificando no gráfico o ponto de abscissa $\Delta t = 80 - 25 = 55^\circ\text{C}$ e ordenada $V = 3$ litros, o mesmo pertence à zona com volume expandido $V_e = 0,15$ litros. O depósito aconselhado deverá ter um volume duplo respeito a V_e ou seja 0,30 litros e portanto o depósito idóneo é o BA 030.

Nas páginas seguintes estão indicados os volumes de óleo, puramente indicativos, necessários para o enchimento, em função da posição de montagem. No que diz respeito aos dados que faltam, contatar o Serviço Técnico Reggiana Riduttori.

Type / Tipo / Tipo	Volume huile Volumen aceite Volume óleo [l]			Masse Masa Massa [kg]
	Position / Posición / Posição			
	A	E	G	

RR2500 L1	MS	3.2	6.3	110
	MC	3.2	6.3	145
	FS	2.9	5.9	100
	MH	3.2	6.3	110
RR2500 L2	MS	3.7	7.4	140
	MC	3.7	7.4	175
	FS	3.5	6.9	130
	MH	3.7	7.4	140
RR2500 L3	ZI	-	10.7	310
	MS	4.4	8.9	150
	MC	4.4	8.9	190
	FS	4.2	8.4	140
RR2500 L4	MH	4.4	8.9	150
	ZI	-	12.2	320
	MS	5.6	11.3	160
	MC	5.6	11.3	195
RR3200 L1	FS	5.4	10.8	150
	MH	5.6	11.3	160
	ZI	-	14.6	330
	MS	4.3	8.6	145
RR3200 L2	MC	4.3	8.6	155
	FS	4.1	8.2	125
	MH	4.3	8.6	135
	MS	4.8	9.6	180
RR3200 L3	MC	4.8	9.6	190
	FS	4.6	9.2	160
	MH	4.8	9.6	170
	ZI	-	12.3	330
RR3200 L4	MS	5.7	11.4	200
	MC	5.7	11.4	210
	FS	5.5	11	180
	MH	5.7	11.4	190
RR3200 L4	ZI	-	14.1	350
	MS	7.6	15.1	210
	MC	7.6	15.1	220
	FS	7.4	14.7	190

Type / Tipo / Tipo	Volume huile Volumen aceite Volume óleo [l]				Masse Masa Massa [kg]
	Position / Posición / Posição				
	B0	F0 F1 F2 F3	H0 H1 H2 H3	B1 B2 B3	

RR2500 A2(A)	MS	14.7	7.4	195
	MC	14.7	7.4	230
	FS	14.3	7.1	185
	MH	14.7	7.4	195
RR2500 A2(B)	MS	19.3	9.7	205
	MC	19.3	9.7	240
	FS	18.8	9.4	190
	MH	19.3	9.7	200
RR2500 A2(C)	MS	29.6	14.8	315
	MC	29.6	14.8	350
	FS	29.2	14.6	300
	MH	29.6	14.8	310
RR2500 A3	MS	12.1	6	185
	MC	12.1	6	220
	FS	11.6	5.8	170
	MH	12.1	6	180
RR2500 A4	MS	10.3	5.2	170
	MC	10.3	5.2	205
	FS	9.9	4.9	160
	MH	10.3	5.2	170
RR3200 A2(A)	MS	17	8.5	230
	MC	17	8.5	240
	FS	16.6	8.3	210
	MH	17	8.5	220
RR3200 A2(B)	MS	21.6	10.8	240
	MC	21.6	10.8	250
	FS	21.2	10.6	220
	MH	21.6	10.8	230
RR3200 A2(C)	MS	31.9	16.0	345
	MC	31.9	16.0	355
	FS	31.5	15.8	325
	MH	31.9	16.0	335
RR3200 A3(A)	MS	14.3	7.1	230
	MC	14.3	7.1	240
	FS	13.9	6.9	210
	MH	14.3	7.1	220

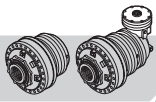

Tipo / Type / Typ	Volume olio Oil volume Ölmenge [l]			Massa Mass Gewicht [kg]
	Posizione / Position / Position			
	A	E	G	

RR3200 L4	MH	7.6	15.1	200
	ZI	-	17.8	360
RR4000 L1	MS	6.1	12.2	180
	MC	6.1	12.2	185
	FS	5.8	11.7	160
	MH	6.1	12.2	170
RR4000 L2	MS	6.4	12.7	230
	MC	6.4	12.7	235
	FS	6.1	12.2	210
	MH	6.4	12.7	220
RR4000 L3	ZI	-	17.7	450
	MS	7.6	15.1	245
	MC	7.6	15.1	255
	FS	7.3	14.5	225
RR4000 L4	MH	7.6	15.1	235
	ZI	-	20.1	465
	MS	10.8	21.6	260
	MC	10.8	21.6	265
RR5200 L1	FS	10.5	21	240
	MH	10.8	21.6	250
	ZI	-	26.6	480
	MS	6.3	12.5	210
RR5200 L2	MC	6.3	12.5	220
	FS	6	12.1	180
	MH	6.3	12.5	195
	MS	6.5	13	260
RR5200 L3	MC	6.5	13	270
	FS	6.3	12.6	230
	MH	6.5	13	245
	ZI	-	17.4	465
RR5200 L4	MS	7.7	15.4	280
	MC	7.7	15.4	285
	FS	7.5	15	250
	MH	7.7	15.4	260
RR6500 L1	ZI	-	19.8	485
	MS	10.4	20.7	290
	MC	10.4	20.7	300
	FS	10.1	20.2	260
RR6500 L2	MH	10.4	20.7	275
	ZI	-	25.1	495
	MS	7.7	15.4	275
	MC	7.7	15.4	290
RR6500 L3	FS	7.3	14.6	250
	MH	7.7	15.4	270
	MS	9.1	18.1	365
	MC	9.1	18.1	380
RR6500 L4	FS	8.7	17.3	340
	MH	9.1	18.1	360
	MS	10.6	21.1	395
	MC	10.6	21.1	405
RR6500 L3	FS	10.1	20.3	365
	MH	10.6	21.1	390
	ZI	-	27.1	705
	MS	13.6	27.1	405
RR6500 L4	MC	13.6	27.1	420
	FS	13.2	26.3	380
	MH	13.6	27.1	400
	ZI	-	33.1	720

Tipo / Type / Typ	Volume olio Oil volume Ölmenge [l]				Massa Mass Gewicht [kg]
	Posizione / Position / Position				
	B0	F0 F1 F2 F3	H0 H1 H2 H3	B1 B2 B3	

RR3200 A3(B)	MS	18	9	255
	MC	18	9	265
	FS	17.6	8.8	235
RR3200 A4	MH	18	9	245
	MS	16.1	8	240
	MC	16.1	8	250
RR4000 A2(A)	FS	15.7	7.8	220
	MH	16.1	8	230
	MS	20.6	10.3	260
RR4000 A2(B)	MC	20.6	10.3	265
	FS	20.1	10	240
	MH	20.6	10.3	250
RR4000 A2(C)	MS	25.2	12.6	270
	MC	25.2	12.6	280
	FS	24.6	12.3	250
RR4000 A3(A)	MH	25.2	12.6	260
	MS	35.5	17.8	380
	MC	35.5	17.8	390
RR4000 A3(B)	FS	34.9	17.5	360
	MH	35.5	17.8	370
	MS	17.4	8.7	265
RR4000 A4	MC	17.4	8.7	275
	FS	16.8	8.4	245
	MH	17.4	8.7	255
RR5200 A2(A)	MS	21.1	10.6	310
	MC	21.1	10.6	320
	FS	20.6	10.3	290
RR5200 A2(B)	MH	21.1	10.6	300
	MS	19.8	9.9	285
	MC	19.8	9.9	290
RR5200 A2(C)	FS	19.2	9.6	265
	MH	19.8	9.9	275
	MS	20.9	10.5	290
RR5200 A3(A)	MC	20.9	10.5	300
	FS	20.5	10.2	260
	MH	20.9	10.5	270
RR5200 A3(B)	MS	25.5	12.8	305
	MC	25.5	12.8	310
	FS	25	12.5	275
RR5200 A3(C)	MH	25.5	12.8	285
	MS	35.8	17.9	410
	MC	35.8	17.9	420
RR5200 A4	FS	35.4	17.7	385
	MH	35.8	17.9	395
	MS	17.7	8.9	300
RR6500 L1	MC	17.7	8.9	305
	FS	17.3	8.6	270
	MH	17.7	8.9	280
RR6500 L2	MS	21.4	10.7	345
	MC	21.4	10.7	350
	FS	21	10.5	315
RR6500 L3	MH	21.4	10.7	325
	MS	26	13	355
	MC	26	13	360
RR6500 L4	FS	25.5	12.8	325
	MH	26	13	335
	MS	20.1	10.1	320
RR6500 L3	MC	20.1	10.1	325
	FS	19.6	9.8	290
	MH	20.1	10.1	300

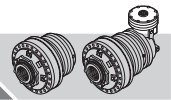

Type / Tipo / Tipo	Volume huile Volumen aceite Volume óleo [l]			Masse Masa Massa [kg]
	Position / Posición / Posição			
	A	E	G	

RR3200 L4	MH	7.6	15.1	200
	ZI	-	17.8	360
RR4000 L1	MS	6.1	12.2	180
	MC	6.1	12.2	185
	FS	5.8	11.7	160
	MH	6.1	12.2	170
RR4000 L2	MS	6.4	12.7	230
	MC	6.4	12.7	235
	FS	6.1	12.2	210
	MH	6.4	12.7	220
RR4000 L3	ZI	-	17.7	450
	MS	7.6	15.1	245
	MC	7.6	15.1	255
	FS	7.3	14.5	225
RR4000 L4	MH	7.6	15.1	235
	ZI	-	20.1	465
	MS	10.8	21.6	260
	MC	10.8	21.6	265
RR5200 L1	FS	10.5	21	240
	MH	10.8	21.6	250
	ZI	-	26.6	480
	MS	6.3	12.5	210
RR5200 L2	MC	6.3	12.5	220
	FS	6	12.1	180
	MH	6.3	12.5	195
	MS	6.5	13	260
RR5200 L3	MC	6.5	13	270
	FS	6.3	12.6	230
	MH	6.5	13	245
	ZI	-	17.4	465
RR5200 L4	MS	7.7	15.4	280
	MC	7.7	15.4	285
	FS	7.5	15	250
	MH	7.7	15.4	260
RR6500 L1	ZI	-	19.8	485
	MS	10.4	20.7	290
	MC	10.4	20.7	300
	FS	10.1	20.2	260
RR6500 L2	MH	10.4	20.7	275
	ZI	-	25.1	495
	MS	7.7	15.4	275
	MC	7.7	15.4	290
RR6500 L3	FS	7.3	14.6	250
	MH	7.7	15.4	270
	MS	9.1	18.1	365
	MC	9.1	18.1	380
RR6500 L4	FS	8.7	17.3	340
	MH	9.1	18.1	360
	MS	10.6	21.1	395
	MC	10.6	21.1	405
RR6500 L3	FS	10.1	20.3	365
	MH	10.6	21.1	390
	ZI	-	27.1	705
	MS	13.6	27.1	405
RR6500 L4	MC	13.6	27.1	420
	FS	13.2	26.3	380
	MH	13.6	27.1	400
	ZI	-	33.1	720

Type / Tipo / Tipo	Volume huile Volumen aceite Volume óleo [l]				Masse Masa Massa [kg]
	Position / Posición / Posição				
	B0	F0 F1 F2 F3	H0 H1 H2 H3	B1 B2 B3	

RR3200 A3(B)	MS	18	9	255
	MC	18	9	265
	FS	17.6	8.8	235
RR3200 A4	MH	18	9	245
	MS	16.1	8	240
	MC	16.1	8	250
RR4000 A2(A)	FS	15.7	7.8	220
	MH	16.1	8	230
	MS	20.6	10.3	260
RR4000 A2(B)	MC	20.6	10.3	265
	FS	20.1	10	240
	MH	20.6	10.3	250
RR4000 A2(C)	MS	25.2	12.6	270
	MC	25.2	12.6	280
	FS	24.6	12.3	250
RR4000 A3(A)	MH	25.2	12.6	260
	MS	35.5	17.8	380
	MC	35.5	17.8	390
RR4000 A3(B)	FS	34.9	17.5	360
	MH	35.5	17.8	370
	MS	17.4	8.7	265
RR4000 A4	MC	17.4	8.7	275
	FS	16.8	8.4	245
	MH	17.4	8.7	255
RR5200 A2(A)	MS	21.1	10.6	310
	MC	21.1	10.6	320
	FS	20.6	10.3	290
RR5200 A2(B)	MH	21.1	10.6	300
	MS	19.8	9.9	285
	MC	19.8	9.9	290
RR5200 A2(C)	FS	19.2	9.6	265
	MH	19.8	9.9	275
	MS	20.9	10.5	290
RR5200 A3(A)	MC	20.9	10.5	300
	FS	20.5	10.2	260
	MH	20.9	10.5	270
RR5200 A3(B)	MS	25.5	12.8	305
	MC	25.5	12.8	310
	FS	25	12.5	275
RR5200 A3(C)	MH	25.5	12.8	285
	MS	35.8	17.9	410
	MC	35.8	17.9	420
RR5200 A4	FS	35.4	17.7	385
	MH	35.8	17.9	395
	MS	17.7	8.9	300
RR6500 A2(A)	MC	17.7	8.9	305
	FS	17.3	8.6	270
	MH	17.7	8.9	280
RR6500 A2(B)	MS	21.4	10.7	345
	MC	21.4	10.7	350
	FS	21	10.5	315
RR6500 A2(C)	MH	21.4	10.7	325
	MS	26	13	355
	MC	26	13	360
RR6500 A3(A)	FS	25.5	12.8	325
	MH	26	13	335
	MS	20.1	10.1	320
RR6500 A3(B)	MC	20.1	10.1	325
	FS	19.6	9.8	290
	MH	20.1	10.1	300

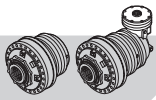

Tipo / Type / Typ	Volume olio Oil volume Ölmenge [l]			Massa Mass Gewicht [kg]
	Posizione / Position / Position			
	A	E	G	

RR8000 L1	MS	13.8	27.6	365
	MC	13.8	27.6	380
	FS	13.6	27.1	335
	MH	13.8	27.6	360
RR8000 L2	MS	16.7	33.3	495
	MC	16.7	33.3	515
	FS	16.4	32.9	470
	MH	16.7	33.3	495
RR8000 L3	MS	19.4	38.8	545
	MC	19.4	38.8	565
	FS	19.2	38.3	520
	MH	19.4	38.8	545
RR8000 L4	ZI	-	48.4	1055
	MS	24.4	48.8	565
	MC	24.4	48.8	580
	FS	24.2	48.4	535
RR10000 L1	MH	24.4	48.8	560
	ZI	-	58.4	1070
	MS	13.8	27.6	375
	MC	13.8	27.6	390
RR10000 L2	FS	13.6	27.1	345
	MH	13.8	27.6	370
	MS	16.7	33.3	505
	MC	16.7	33.3	525
RR10000 L3	FS	16.4	32.9	475
	MH	16.7	33.3	505
	MS	19.1	38.3	555
	MC	19.1	38.3	575
RR10000 L4	FS	18.9	37.8	525
	MH	19.1	38.3	555
	ZI	-	47.9	1060
	MS	23.1	46.3	575
RR15000 L1	MC	23.1	46.3	590
	FS	22.9	45.8	545
	MH	23.1	46.3	570
	ZI	-	55.9	1080
RR15000 L2	FS	17.6	35.2	540
	MH	17.9	35.8	505
RR15000 L3	FS	20	40	625
	MH	20.3	40.6	590
RR15000 L4	FS	21.9	43.8	675
	MH	22.2	44.3	640
RR20000 L1	FS	27.8	55.6	690
	MH	28.1	56.2	655
RR20000 L2	FS	23.9	47.9	755
	MH	23.9	47.8	735
RR20000 L3	FS	26	52	965
	MH	26	51.9	945
RR20000 L4	FS	29.3	58.6	1050
	MH	29.3	58.6	1030
RR25000 L1	FS	38.2	76.4	1080
	MH	38.1	76.3	1060
RR25000 L2	FS	33.3	66.7	980
	MH	33.3	66.7	1020
RR25000 L3	FS	41	82	1275
	MH	41	82	1315
RR25000 L4	FS	46.5	93	1410
	MH	46.5	93	1450
RR30000 L1	FS	58.1	116.2	1460
	MH	58.1	116.2	1500
RR30000 L2	FS	49.3	98.5	1430
	MH	49.3	98.5	1460
RR30000 L3	FS	56	112	1900
	MH	56	112	1925
RR30000 L4	FS	63.4	126.8	1980
	MH	63.4	126.8	2010
RR30000 L5	FS	84.4	168.7	2030
	MH	84.4	168.7	2060

Tipo / Type / Typ	Volume olio Oil volume Ölmenge [l]				Massa Mass Gewicht [kg]
	Posizione / Position / Position				
	B0	F0 F1 F2 F3	H0 H1 H2 H3	B1 B2 B3	

RR6500 A2	MS	38.7	19.3	480
	MC	38.7	19.3	495
	FS	37.8	18.9	455
	MH	38.7	19.3	480
RR6500 A3(A)	MS	26.5	13.3	450
	MC	26.5	13.3	460
	FS	25.7	12.9	420
	MH	26.5	13.3	445
RR6500 A3(B)	MS	31.1	15.5	455
	MC	31.1	15.5	470
	FS	30.3	15.1	430
	MH	31.1	15.5	450
RR6500 A3(C)	MS	41.4	20.7	565
	MC	41.4	20.7	580
	FS	40.6	20.3	540
	MH	41.4	20.7	560
RR6500 A4	MS	25.8	12.9	435
	MC	25.8	12.9	450
	FS	25.0	12.5	410
	MH	25.8	12.9	435
RR8000 A3(A)	MS	41.7	20.9	575
	MC	41.7	20.9	595
	FS	41.3	20.6	550
	MH	41.7	20.9	575
RR8000 A3(B)	MS	46.3	23.1	590
	MC	46.3	23.1	610
	FS	45.8	22.9	560
	MH	46.3	23.1	590
RR8000 A3(C)	MS	56.6	28.3	700
	MC	56.6	28.3	715
	FS	56.2	28.1	670
	MH	56.6	28.3	695
RR8000 A4(A)	MS	43.4	23.6	585
	MC	43.4	23.6	600
	FS	43.0	21.5	555
	MH	43.4	23.6	580
RR8000 A4(B)	MS	47.2	23.6	630
	MC	47.2	23.6	645
	FS	46.7	23.4	600
	MH	47.2	23.6	625
RR10000 A3(A)	MS	41.7	20.9	585
	MC	41.7	20.9	605
	FS	41.3	20.6	555
	MH	41.7	20.9	580
RR10000 A3(B)	MS	46.3	23.1	600
	MC	46.3	23.1	620
	FS	45.8	22.9	570
	MH	46.3	23.1	595
RR10000 A3(C)	MS	56.6	28.3	710
	MC	56.6	28.3	730
	FS	56.2	28.1	680
	MH	56.6	28.3	705
RR10000 A4(A)	MS	43.0	21.5	595
	MC	43.0	21.5	615
	FS	42.5	21.3	565
	MH	43.0	21.5	590
RR10000 A4(B)	MS	46.7	23.3	640
	MC	46.7	23.3	660
	FS	46.2	23.1	610
	MH	46.7	23.3	635
RR15000 A3(A)	FS	48.4	24.2	705
	MH	49.0	24.5	665
RR15000 A3(B)	FS	53.0	26.5	720
	MH	53.5	26.8	680
RR15000 A3(C)	FS	63.3	31.7	825
	MH	63.8	31.9	790
RR15000 A4(A)	FS	48.5	24.2	710
	MH	49.0	24.5	675

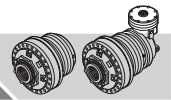

Type / Tipo / Tipo	Volume huile Volumen aceite Volume óleo [l]			Masse Masa Massa [kg]
	Position / Posición / Posição			
	A	E	G	

RR8000 L1	MS	13.8	27.6	365
	MC	13.8	27.6	380
	FS	13.6	27.1	335
	MH	13.8	27.6	360
RR8000 L2	MS	16.7	33.3	495
	MC	16.7	33.3	515
	FS	16.4	32.9	470
	MH	16.7	33.3	495
RR8000 L3	MS	19.4	38.8	545
	MC	19.4	38.8	565
	FS	19.2	38.3	520
	MH	19.4	38.8	545
RR8000 L4	ZI	-	48.4	1055
	MS	24.4	48.8	565
	MC	24.4	48.8	580
	FS	24.2	48.4	535
RR10000 L1	MH	24.4	48.8	560
	ZI	-	58.4	1070
	MS	13.8	27.6	375
	MC	13.8	27.6	390
RR10000 L2	FS	13.6	27.1	345
	MH	13.8	27.6	370
	MS	16.7	33.3	505
	MC	16.7	33.3	525
RR10000 L3	FS	16.4	32.9	475
	MH	16.7	33.3	505
	MS	19.1	38.3	555
	MC	19.1	38.3	575
RR10000 L4	FS	18.9	37.8	525
	MH	19.1	38.3	555
	ZI	-	47.9	1060
	MS	23.1	46.3	575
RR15000 L1	MC	23.1	46.3	590
	FS	22.9	45.8	545
	MH	23.1	46.3	570
	ZI	-	55.9	1080
RR15000 L2	FS	17.6	35.2	540
	MH	17.9	35.8	505
RR15000 L3	FS	20	40	625
	MH	20.3	40.6	590
RR15000 L4	FS	21.9	43.8	675
	MH	22.2	44.3	640
RR20000 L1	FS	27.8	55.6	690
	MH	28.1	56.2	655
RR20000 L2	FS	23.9	47.9	755
	MH	23.9	47.8	735
RR20000 L3	FS	26	52	965
	MH	26	51.9	945
RR20000 L4	FS	29.3	58.6	1050
	MH	29.3	58.6	1030
RR25000 L1	FS	38.2	76.4	1080
	MH	38.1	76.3	1060
RR25000 L2	FS	33.3	66.7	980
	MH	33.3	66.7	1020
RR25000 L3	FS	41	82	1275
	MH	41	82	1315
RR25000 L4	FS	46.5	93	1410
	MH	46.5	93	1450
RR30000 L1	FS	58.1	116.2	1460
	MH	58.1	116.2	1500
RR30000 L2	FS	49.3	98.5	1430
	MH	49.3	98.5	1460
RR30000 L3	FS	56	112	1900
	MH	56	112	1925
RR30000 L4	FS	63.4	126.8	1980
	MH	63.4	126.8	2010
RR30000 L5	FS	84.4	168.7	2030
	MH	84.4	168.7	2060

Type / Tipo / Tipo	Volume huile Volumen aceite Volume óleo [l]				Masse Masa Massa [kg]
	Position / Posición / Posição				
	B0	F0 F1 F2 F3	H0 H1 H2 H3	B1 B2 B3	

RR6500 A2	MS	38.7	19.3	480
	MC	38.7	19.3	495
	FS	37.8	18.9	455
	MH	38.7	19.3	480
RR6500 A3(A)	MS	26.5	13.3	450
	MC	26.5	13.3	460
	FS	25.7	12.9	420
	MH	26.5	13.3	445
RR6500 A3(B)	MS	31.1	15.5	455
	MC	31.1	15.5	470
	FS	30.3	15.1	430
	MH	31.1	15.5	450
RR6500 A3(C)	MS	41.4	20.7	565
	MC	41.4	20.7	580
	FS	40.6	20.3	540
	MH	41.4	20.7	560
RR6500 A4	MS	25.8	12.9	435
	MC	25.8	12.9	450
	FS	25.0	12.5	410
	MH	25.8	12.9	435
RR8000 A3(A)	MS	41.7	20.9	575
	MC	41.7	20.9	595
	FS	41.3	20.6	550
	MH	41.7	20.9	575
RR8000 A3(B)	MS	46.3	23.1	590
	MC	46.3	23.1	610
	FS	45.8	22.9	560
	MH	46.3	23.1	590
RR8000 A3(C)	MS	56.6	28.3	700
	MC	56.6	28.3	715
	FS	56.2	28.1	670
	MH	56.6	28.3	695
RR8000 A4(A)	MS	43.4	23.6	585
	MC	43.4	23.6	600
	FS	43.0	21.5	555
	MH	43.4	23.6	580
RR8000 A4(B)	MS	47.2	23.6	630
	MC	47.2	23.6	645
	FS	46.7	23.4	600
	MH	47.2	23.6	625
RR10000 A3(A)	MS	41.7	20.9	585
	MC	41.7	20.9	605
	FS	41.3	20.6	555
	MH	41.7	20.9	580
RR10000 A3(B)	MS	46.3	23.1	600
	MC	46.3	23.1	620
	FS	45.8	22.9	570
	MH	46.3	23.1	595
RR10000 A3(C)	MS	56.6	28.3	710
	MC	56.6	28.3	730
	FS	56.2	28.1	680
	MH	56.6	28.3	705
RR10000 A4(A)	MS	43.0	21.5	595
	MC	43.0	21.5	615
	FS	42.5	21.3	565
	MH	43.0	21.5	590
RR10000 A4(B)	MS	46.7	23.3	640
	MC	46.7	23.3	660
	FS	46.2	23.1	610
	MH	46.7	23.3	635
RR15000 A3(A)	FS	48.4	24.2	705
	MH	49.0	24.5	665
RR15000 A3(B)	FS	53.0	26.5	720
	MH	53.5	26.8	680
RR15000 A3(C)	FS	63.3	31.7	825
	MH	63.8	31.9	790
RR15000 A4(A)	FS	48.5	24.2	710
	MH	49.0	24.5	675

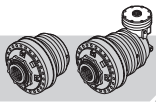

Tipo / Type / Typ	Volume olio Oil volume Ölmenge [l]			Massa Mass Gewicht [kg]
	Posizione / Position / Position			
	A	E	G	

RR40000 L1	FS	49.3	98.5	1450
	MH	49.3	98.5	1490
RR40000 L2	FS	56	112	1920
	MH	56	112	1960
RR40000 L3	FS	63.4	126.8	2000
	MH	63.4	126.8	2040
RR40000 L4	FS	80	160	2050
	MH	80	160	2090
RR55000 L1	FS	70.9	141.8	1950
	MH	70.9	141.8	2010
RR55000 L2	FS	78.4	156.8	2600
	MH	78.4	156.8	2660
RR55000 L3	FS	88.2	176.3	2810
	MH	88.2	176.3	2870
RR55000 L4	FS	113	226	2900
	MH	113	226	2960

Tipo / Type / Typ	Volume olio Oil volume Ölmenge [l]				Massa Mass Gewicht [kg]
	Posizione / Position / Position				
	B0	F0 F1 F2 F3	H0 H1 H2 H3	B1 B2 B3	

RR15000 A4(B)	FS	52.2		26.1	760
	MH	52.7		26.4	720
RR15000 A4(C)	FS	56.7		28.4	770
	MH	57.3		28.6	730
RR20000 A3	FS	75.3		37.7	1170
	MH	75.2		37.6	1150
RR20000 A4(A)	FS	67.0		33.5	1135
	MH	67.0		33.5	1115
RR20000 A4(B)	FS	71.6		35.8	1145
	MH	71.5		35.8	1125
RR20000 A4(C)	FS	81.9		41	1255
	MH	81.8		40.9	1235
RR25000 A4(A)	FS	101.4		50.7	1490
	MH	101.4		50.7	1525
RR25000 A4(B)	FS	106.0		53	1500
	MH	106.0		53	1540
RR25000 A4(C)	FS	116.3		58.2	1610
	MH	116.3		58.2	1650
RR30000 A4(A)	FS	135.2		67.6	2060
	MH	135.2		67.6	2090
RR30000 A4(B)	FS	139.8		69.9	2075
	MH	139.8		69.9	2100
RR30000 A4(C)	FS	150.1		75	2180
	MH	150.1		75	2210
RR40000 A4(A)	FS	135.2		67.6	2080
	MH	135.2		67.6	2120
RR40000 A4(B)	FS	139.8		69.9	2095
	MH	139.8		69.9	2135
RR40000 A4(C)	FS	150.1		75	2200
	MH	150.1		75	2240
RR55000 A4	FS	199.6		99.8	3020
	MH	199.6		99.8	3080

6.6 Sistemi ausiliari di raffreddamento

Quando la potenza da trasmettere è superiore alla potenza termica che il riduttore è in grado di smaltire, è necessario impiegare un sistema ausiliario di raffreddamento che, oltre a permettere lo smaltimento della potenza termica in eccesso P_S , consente di effettuare la filtrazione del lubrificante, prolungando la vita di ingranaggi e cuscinetti.

Sono disponibili, a richiesta, tre tipi di sistemi ausiliari di raffreddamento, le cui caratteristiche e dimensioni sono indicate di seguito.

6.6 Auxiliary cooling systems

When the power to be transmitted is higher than the thermal power the reduction gear is able to get rid of, you will have to use an auxiliary cooling system which, besides getting rid of the thermal power in excess P_S , also allows the lubricant to be filtered which prolongs the life of both gears and bearings.

On request three types of auxiliary cooling systems are available. Their specifications and dimensions are given in the following table.

6.6 Zusätzliche Kühlsysteme

Wenn die Leistung, die übertragen wird, die Wärmeleistung übersteigt, die das Planetengetriebe ableiten kann, muss ein zusätzliches Kühlsystem installiert werden, das nicht nur eine Ableitung der überschüssigen Wärmeleistung P_S erlaubt, sondern auch ein Filtern vom Schmieröl möglich macht und damit die Lebensdauer der Zahnräder und Lager erhöht.

Auf Wunsch sind drei verschiedene Kühlsysteme erhältlich (siehe Tabelle unten).

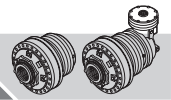

Type / Tipo / Tipo	Volume huile Volumen aceite Volume óleo [l]			Masse Masa Massa [kg]
	Position / Posición / Posição			
	A	E	G	

RR40000 L1	FS	49.3	98.5	1450
	MH	49.3	98.5	1490
RR40000 L2	FS	56	112	1920
	MH	56	112	1960
RR40000 L3	FS	63.4	126.8	2000
	MH	63.4	126.8	2040
RR40000 L4	FS	80	160	2050
	MH	80	160	2090
RR55000 L1	FS	70.9	141.8	1950
	MH	70.9	141.8	2010
RR55000 L2	FS	78.4	156.8	2600
	MH	78.4	156.8	2660
RR55000 L3	FS	88.2	176.3	2810
	MH	88.2	176.3	2870
RR55000 L4	FS	113	226	2900
	MH	113	226	2960

Type / Tipo / Tipo	Volume huile Volumen aceite Volume óleo [l]				Masse Masa Massa [kg]
	B0	Position / Posición / Posição			
		F0 F1 F2 F3	H0 H1 H2 H3	B1 B2 B3	

RR15000 A4(B)	FS	52.2	26.1	760
	MH	52.7	26.4	720
RR15000 A4(C)	FS	56.7	28.4	770
	MH	57.3	28.6	730
RR20000 A3	FS	75.3	37.7	1170
	MH	75.2	37.6	1150
RR20000 A4(A)	FS	67.0	33.5	1135
	MH	67.0	33.5	1115
RR20000 A4(B)	FS	71.6	35.8	1145
	MH	71.5	35.8	1125
RR20000 A4(C)	FS	81.9	41	1255
	MH	81.8	40.9	1235
RR25000 A4(A)	FS	101.4	50.7	1490
	MH	101.4	50.7	1525
RR25000 A4(B)	FS	106.0	53	1500
	MH	106.0	53	1540
RR25000 A4(C)	FS	116.3	58.2	1610
	MH	116.3	58.2	1650
RR30000 A4(A)	FS	135.2	67.6	2060
	MH	135.2	67.6	2090
RR30000 A4(B)	FS	139.8	69.9	2075
	MH	139.8	69.9	2100
RR30000 A4(C)	FS	150.1	75	2180
	MH	150.1	75	2210
RR40000 A4(A)	FS	135.2	67.6	2080
	MH	135.2	67.6	2120
RR40000 A4(B)	FS	139.8	69.9	2095
	MH	139.8	69.9	2135
RR40000 A4(C)	FS	150.1	75	2200
	MH	150.1	75	2240
RR55000 A4	FS	199.6	99.8	3020
	MH	199.6	99.8	3080

6.6 Systèmes auxiliaires de refroidissement

Quand la puissance à transmettre est supérieure à la puissance thermique que le réducteur est en mesure d'évacuer, il faut utiliser un système auxiliaire de refroidissement qui non seulement permet d'évacuer la puissance thermique en excès P_S , mais permet aussi de filtrer la graisse, et par conséquent de prolonger la vie des engrenages et des roulements.

Il existe, en option, trois types de systèmes auxiliaires de refroidissement dont les caractéristiques et les dimensions sont indiquées ci-dessous.

6.6 Sistemas auxiliares de refrigeración

Cuando la potencia a transmitir es mayor que la potencia térmica que el reductor es capaz de eliminar, es necesario utilizar un sistema auxiliar de refrigeración que, además de permitir la eliminación de la potencia térmica en exceso P_S , permite efectuar el filtrado del lubricante, alargando la vida de engranajes y cojinetes.

Hay disponibles, bajo pedido, tres tipos de sistemas auxiliares de refrigeración, cuyas características y medidas se indican a continuación.

6.6 Sistemas auxiliares de arrefecimento

Quando a potência a transmitir é superior à potência térmica que o reductor é capaz de eliminar, é necessário usar um sistema auxiliar de arrefecimento que, além de consentir a eliminação da potência térmica em excesso P_S , consente efetuar a filtragem do lubrificante, prolongando a vida das engrenagens e dos rolamentos.

A pedido é possível obter três tipos de sistemas auxiliares de arrefecimento, cujas características e dimensões estão indicadas a seguir.

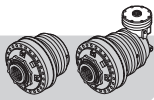

		CSU 04	CSU 10	CSU 20
Portata olio <i>Oil flow rate</i> Öldurchsatz	[l/min]	10	10	23
* Potenza termica dissipata <i>* Thermal power dissipated</i> * abgeleitete Wärmeleistung (per/where /für $\Delta t = t_R - T_a = 40^\circ\text{C}$)	[kW]	4	10	20
Portata aria <i>Air flow rate</i> Luftdurchsatz	[m ³ /h]	700	4080	4500
Potenza assorbita <i>Power consumption</i> Leistungsaufnahme	[kW]	0.5	0.75	1.1
Pressione massima <i>Maximum pressure</i> Höchstdruck	[bar]	6	6	6
Runorosità a 1 metro <i>Noise at 1 metre</i> Lärmpegel im Abstand von 1 Meter	[dB(A)]	-	-	-
Peso <i>Weight</i> Gewicht	[kg]	-	-	-
Tensione di alimentazione <i>Power voltage</i> Versorgungsspannung	[V]	230/400	230/400	230/400
Frequenza di alimentazione <i>Power frequency</i> Versorgungsfrequenz	[Hz]	50/60	50/60	50/60
Indice di protezione <i>Protection level</i> Schutzart	IP	55	55	55
Codice Reggiana Riduttori <i>Reggiana Riduttori Code</i> Code von Reggiana Riduttori	[-]	154F7016	154F7017	154F7018

* Potenza dissipata dallo scambiatore con olio con viscosità: ISO VG 150 a 0 metri s.l.m.

* *Power dissipated by the exchanger with oil viscosity: ISO VG 150 at 0 metres above sea level.*

* Vom Wärmeaustauscher abgeleitete Leistung mit Öl mit einer Viskosität von ISO VG 150 bei 0 m ü. NN.

	A	B	C	D	E	F	ØH	L	M
CSU 04	465	537	418.5	347	280	20	9	179.5	273.5±3
CSU 10	682	549	616.5	555	300	20	9	278.5	471.5±3
CSU 20	830	657	755	695	380	20	9	305	570.5±3

D,E,F,H: quote relative ai 4 fori previsti per il fissaggio
D,E,F,H: dimensions for the 4 fixing holes
 D,E,F,H: Abmessungen bezogen auf die 4 Befestigungslöcher

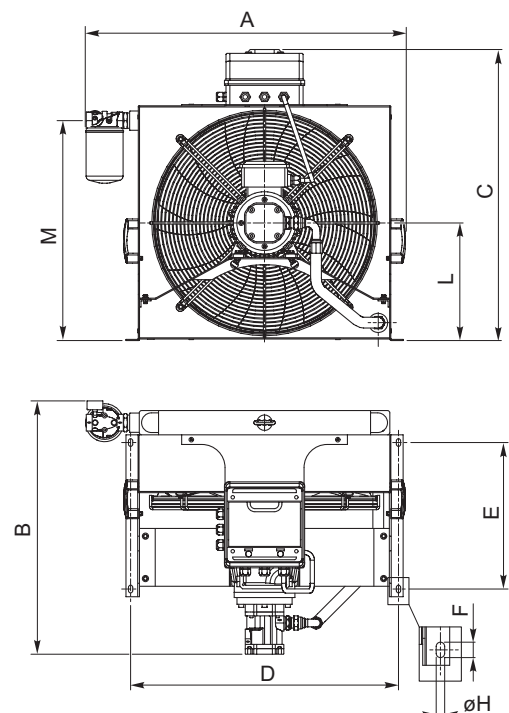

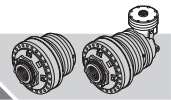

		CSU 04	CSU 10	CSU 20
Débit huile Caudal aceite Caudal óleo	[l/min]	10	10	23
* Puissance thermique dissipée * Potencia térmica disipada * Potência térmica dissipada (pour/para/para $\Delta t = t_R - T_a = 40^\circ\text{C}$)	[kW]	4	10	20
Débit d'air Caudal aire Caudal ar	[m³/h]	700	4080	4500
Puissance absorbée Potencia absorbida Potência consumida	[kW]	0.5	0.75	1.1
Pression maximum Presión máxima Pressão máxima	[bar]	6	6	6
Nuisances sonores à 1 mètre Ruido a 1 metro Rumor a 1 metro	[dB(A)]	-	-	-
Poids Peso Peso	[kg]	-	-	-
Tension d'alimentation Tensión de alimentación Tensão de alimentação	[V]	230/400	230/400	230/400
Fréquence d'alimentation Frecuencia de alimentación Frequência de alimentação	[Hz]	50/60	50/60	50/60
Indice de protection Índice de protección Índice de proteção	IP	55	55	55
Code Reggiana Riduttori Código Reggiana Riduttori Código Reggiana Riduttori	[-]	154F7016	154F7017	154F7018

* Puissance dissipée par l'échangeur avec une huile à viscosité: ISO VG 150 à 0 mètres au-dessus du niveau de la mer.

* Potencia disipada por el intercambiador con aceite con viscosidad: ISO VG 150 a 0 metros s.n.m.

* Potência dissipada pelo permutador com óleo com viscosidade: ISO VG 150 a 0 metros s.n.m.

	A	B	C	D	E	F	ØH	L	M
CSU 04	465	537	418.5	347	280	20	9	179.5	273.5±3
CSU 10	682	549	616.5	555	300	20	9	278.5	471.5±3
CSU 20	830	657	755	695	380	20	9	305	570.5±3

D,E,F,H: quote relative ai 4 fori previsti per il fissaggio
D,E,F,H: dimensions for the 4 fixing holes
D,E,F,H: Abmessungen bezogen auf die 4 Befestigungslöchern

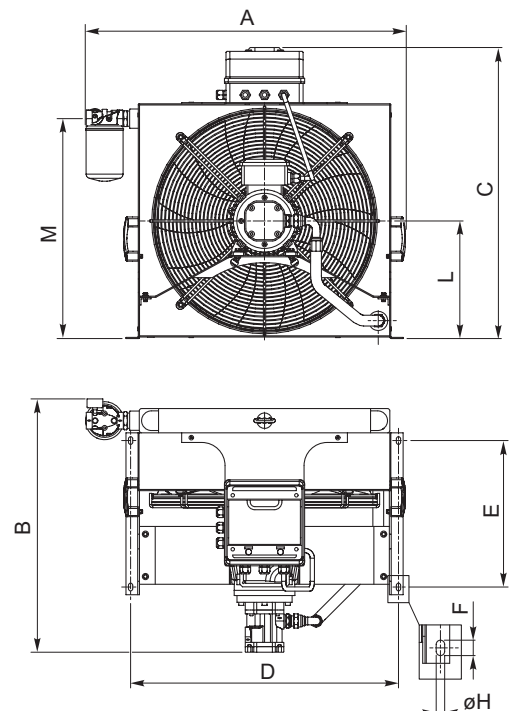

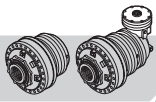

Componenti fondamentali del sistema ausiliario di raffreddamento sono: uno scambiatore di calore olio-aria, una pompa ad ingranaggi (a cilindrata fissa), un motore elettrico, un filtro spin-on (grado di filtrazione 60 μm), un ventilatore coassiale alla pompa e due termostati da installare sul riduttore, uno tarato per la temperatura minima di avviamento del sistema, che inibisce la partenza dell'unità di raffreddamento fino alla temperatura di 60°C e l'altro tarato per una temperatura massima, superata la quale si può azionare un allarme e/o interrompere il funzionamento del riduttore e un manometro per visualizzare la pressione di mandata.

Inoltre per le posizioni di montaggio con asse verticale e comunque in tutti quei casi in cui si adotta il completo riempimento di lubrificante, è necessario montare un vaso di espansione.

Si consiglia, in questi casi, di impiegare il vaso di espansione BA 200.

A richiesta possono essere forniti dei componenti opzionali quali:

- flussimetro per consentire un'indicazione visiva del passaggio di olio;
- pressostato per segnalare, tramite commutazione di contatto elettrico, sovrappressioni all'interno del riduttore;
- centralina con regolazione continua della temperatura mediante valvola di bypass;
- filtro con differente grado di filtrazione (10, 25, 90 o 125 μm);
- termostato con differente temperatura di avviamento (50°C o 40°C)

Il collegamento dei contatti elettrici e del circuito idraulico e tutto il materiale occorrente allo scopo sono a carico del cliente.

La scelta del sistema più idoneo, va fatta in base alla potenza termica P_S che è necessario dissipare e alla differenza Δt tra la temperatura dell'olio all'interno del riduttore t_R e la temperatura ambiente t_a , con l'aiusilio del seguente grafico.

Fundamental components of the auxiliary cooling system are: an oil-air heat exchanger, a gear pump (constant displacement type), an electric motor, a spin-on filter (with a filtering degree of 60 μm), a fan coaxial with the pump and two thermostats to install on the reduction gear, one set for the minimum system start-up temperature, which prevents the cooling unit starting until a temperature of 60°C is reached, and the other set for a maximum temperature which, when exceeded, can trigger an alarm and/or stop the reduction gear working and a gauge to see delivery pressure.

In addition, for the assembly positions with a vertical axis and, of course, whenever the reduction gear is filled up completely with lubricant, an expansion tank has to be mounted.

In these cases we recommend using the BA 200 expansion tank.

On request optional components can be supplied, such as:

- *a flow meter so as to have a visual of the oil's passage;*
- *a pressure switch to indicate overpressures inside the reduction gear by the switching of an electrical contact;*
- *control unit with continuous adjustment of the temperature by means of a bypass valve;*
- *filter with a different filtering degree (10, 25, 90 or 125 μm);*
- *Thermostat with different start-up temperature (either 50°C or 40°C)*

Connection of the electrical contacts and hydraulic circuit and all the material needed for it are the responsibility of the customer.

The choice of the most suitable system must be made based on the thermal power P_S you need to dissipate and on the Δt difference between the temperature of the oil inside the reduction gear t_R and ambient temperature t_a , using this graph to help you.

Das zusätzliche Kühlsystem umfasst folgende Komponenten: ein Öl-Luft-Wärmeaustauscher, eine Zahnradpumpe (mit vorgegebene Hubraum), ein Elektromotor, ein Spin-on Filter (Filterstärke 60 μm), ein koaxiales Gebläse zur Pumpe und zwei Thermostate, die am Planetengetriebe installiert werden. Ein Thermostat wird auf die Mindesttemperatur zum Starten vom Kühlsystem geeicht und verhindert das Einschalten vom Kühlsystem bis zu einer Temperatur von 60°C, der andere Thermostat wird auf die Höchsttemperatur geeicht, bei deren Überschreiten ein Alarm ausgelöst u/o das Planetengetriebe abgeschaltet werden kann und eine Manometer zu Anzeige vom Druck am Eingang.

Bei Montage in Position mit vertikaler Achse und immer dann, wenn mit voller Ölfüllung gearbeitet wird, muss außerdem ein Ausdehnungsgefäß installiert werden.

In diesen Fällen wird dazu geraten, das Ausdehnungsgefäß BA 200 zu installieren.

Auf Wunsch ist folgendes Zubehör erhältlich:

- Durchflussmesser mit Sichtglas für Ölfluss;
- Druckwächter zur Anzeige vom Überdruck im Planetengetriebe durch Umschalten eines elektrischen Kontakts;
- Steuergerät für stufenlose Temperaturregelung mittels Bypass-Ventil;
- Filter mit anderer Filterstärke (10, 25, 90 oder 125 μm);
- Thermostat mit unterschiedlicher Starttemperatur (50°C oder 40°C)

Für den Anschluss der elektrischen Kontakte und vom Ölkreislauf sowie die Bereitstellung des erforderlichen Materials ist der Kunde zuständig.

Das geeignete System wird anhand der Wärmeleistung P_S ausgewählt, die abgeleitet werden muss, und der Differenz Δt zwischen der Öltemperatur im Planetengetriebe t_R und der Umgebungstemperatur t_a , und zwar mit folgender Grafik:

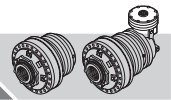

Les composants fondamentaux du système auxiliaire de refroidissement sont: un échangeur de chaleur huile-air, une pompe à engrenages (à cylindrée fixe), un moteur électrique, un filtre spin-on (degré de filtration 60 μm), un rotor de ventilation coaxial à la pompe et deux thermostats à installer sur le réducteur, l'un taré pour la température minimum de démarrage du système, qui inhibe le démarrage de l'unité de refroidissement jusqu'à la température de 60°C et l'autre, taré pour une température maximum, au-delà de laquelle on peut déclencher une alarme et/ou interrompre le fonctionnement du réducteur, et un manomètre pour visualiser la pression de refoulement

De plus, pour les positions de montage avec axe vertical et de toute façon dans tous les cas où on adopte le nourrissage complet de lubrifiant, il est nécessaire de monter un vase d'expansion.

Il est conseillé, dans ces cas-là, d'utiliser le vase d'expansion BA 200.

Il existe, en option, des composants tels que:

- le fluxmètre, pour permettre une indication visuelle du passage de l'huile;
- le pressostat pour signaler, par commutation de contact électrique, toute surpression dans le réducteur;
- centrale avec réglage continu de la température par l'intermédiaire d'une vanne de dérivation;
- le filtre avec un degré de filtration (10, 25, 90 ou 125 μm);
- thermostat avec différente température de démarrage (50°C ou 40°C)

Le branchement des contacts électriques et du circuit hydraulique et tout le matériel utile sont à la charge du client.

Le choix du système le plus approprié doit être fait en fonction de la puissance thermique P_S nécessaire à dissiper et à la différence Δt entre la température de l'huile dans le réducteur t_R et la température ambiante t_a , à l'aide du graphique ci-dessous.

Los componentes fundamentales del sistema auxiliar de refrigeración son: un intercambiador de calor aceite-aire, una bomba de engranajes (de cilindrada fija), un motor eléctrico, un filtro spin-on (grado de filtración 60 μm), un ventilador coaxial respecto a la bomba y dos termostatos a instalar en el reductor, uno calibrado para la temperatura mínima de arranque del sistema, que impide el arranque de la unidad de refrigeración hasta la temperatura de 60°C y el otro calibrado para una temperatura máxima, superada la cual se puede activar una alarma y/o interrumpir el funcionamiento del reductor y un manómetro para visualizar la presión de impulsión.

Además, para las posiciones de montaje con eje vertical y de todas maneras en todos los casos en que se efectúa el llenado completo de lubricante, es necesario montar un vaso de expansión.

Se aconseja, en estos casos, utilizar el vaso de expansión BA 200.

Bajo pedido se pueden proporcionar unos componentes opcionales como:

- *medidor de flujo para consentir una indicación visual del paso de aceite;*
- *presostato para señalar, trámite conmutación de contacto eléctrico, sobrepresiones dentro del reductor;*
- *centralita con regulación continua de la temperatura por medio de válvula de bypass;*
- *filtro con distinto grado de filtración (10, 25, 90 ó 125 μm);*
- *termostato con diferente temperatura de arranque (50°C ó 40°C)*

El conexionado de los contactos eléctricos y del circuito hidráulico y todo el material necesario para ello son a cargo del cliente.

La selección del sistema más idóneo debe ser efectuada sobre la base de la potencia térmica P_S que es necesario disipar y de la diferencia Δt entre la temperatura del aceite dentro del reductor t_R y la temperatura ambiente t_a , con el auxilio del siguiente gráfico.

Os componentes fundamentais do sistema auxiliar de arrefecimento são: um permutador de calor óleo-ar, uma bomba de engrenagens (com cilindrada fixa), um motor elétrico, um filtro spin-on (grau de filtragem 60 μm), um ventilador coaxial à bomba e dois termostatos a instalar no reductor, um regulado para a temperatura mínima de início de trabalho do sistema, que inibe a partida da unidade de arrefecimento até à temperatura de 60°C e o outro regulado para uma temperatura máxima, superada a qual se pode accionar um alarme e/ou interromper o funcionamento do reductor e um manómetro para visualizar a pressão de ida.

Além disso, para as posições de montagem com eixo vertical e em todos aqueles casos em que se adota o completo enchimento de lubrificante, é necessário montar um depósito de expansão.

Aconselhamos, nestes casos, usar o depósito de expansão BA 200.

A pedido, podem ser fornecidos os componentes opcionais como:

- fluxímetro para consentir uma indicação visual da passagem do óleo;
- pressostato para assinalar, através de comutação de contato elétrico, sobrepresões no interior do reductor;
- Central com regulação contínua da temperatura mediante válvula de bypass;
- filtro com diferente grau de filtragem (10, 25, 90 ou 125 μm);
- Termostato com temperatura de arranque diferente (50°C ou 40°C).

A ligação dos contatos elétricos e do circuito hidráulico assim como todo o material necessário para este fim, são a cargo do cliente.

A escolha do sistema mais idóneo, é feita segundo a potência térmica P_S que é necessário dissipar e à diferença Δt entre a temperatura do óleo no interior do reductor t_R e a temperatura ambiente t_a , com a ajuda do seguinte gráfico.

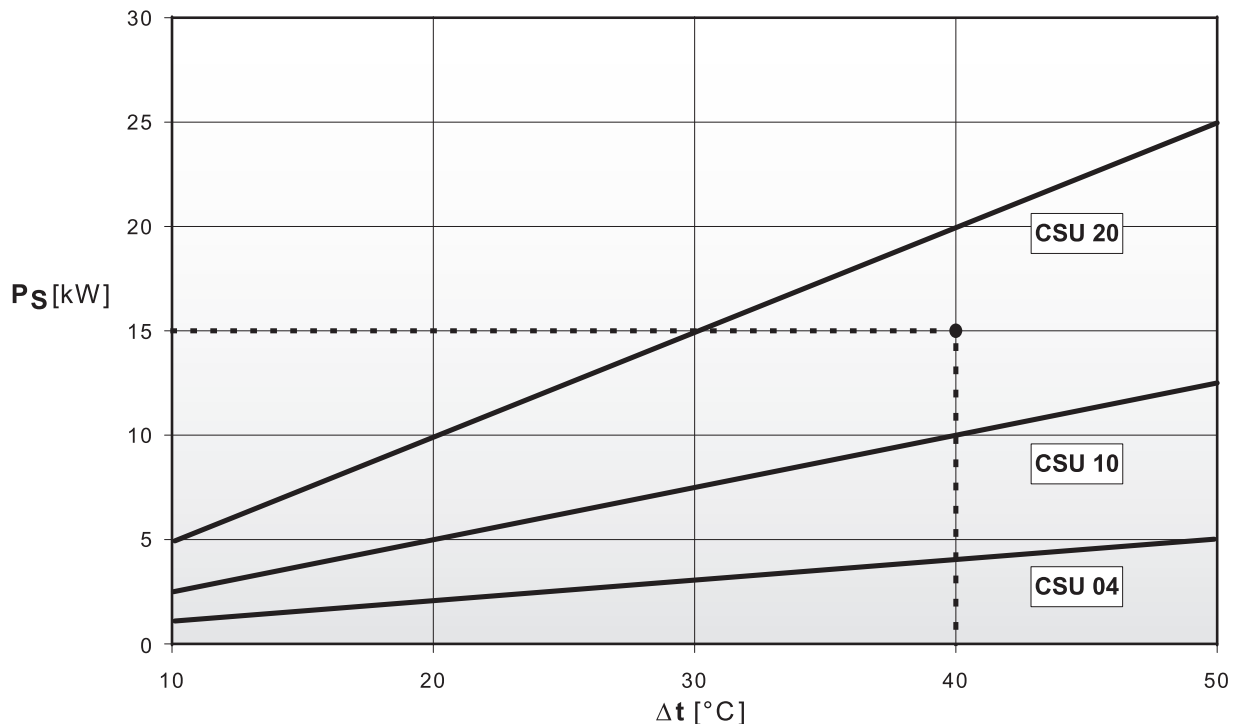
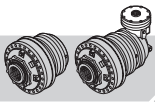

Esempio

Si deve dimensionare un sistema ausiliario di raffreddamento per smaltire una potenza termica $P_S = 15$ kW da un riduttore che lavora alla temperatura di esercizio di 60°C , con temperatura ambiente di 20°C .

Individuando sul grafico il punto di ascissa $\Delta t = 60 - 20 = 40^\circ\text{C}$ ed ordinata $P_S = 15$ kW, questo ricade nella zona indicata con CSU 20. Dunque il sistema idoneo è proprio il CSU 20.

Il collegamento idraulico del sistema ausiliario di raffreddamento va eseguito in modo da aspirare l'olio (ed eventuali detriti) dal punto più in basso (punto (3) nelle figure delle posizioni di montaggio) ed effettuare la mandata da un punto sufficientemente distante dall'aspirazione, in modo da agevolare il ricambio d'olio all'interno del riduttore. Qualora la dimensione del foro di aspirazione fosse insufficiente a smaltire la portata della pompa, occorre prevedere due o più punti di aspirazione, in modo da scongiurare il rischio di cavitazione. Anche per la mandata possono essere impiegati due o più fori di collegamento, ad esempio nel caso di riduttori multistadio.

Example

An auxiliary cooling system has to be sized to get rid of a thermal power of $P_S = 15$ kW from a reduction gear working at an operating temperature of 60°C with an ambient temperature of 20°C .

Finding the abscissa $\Delta t = 60 - 20 = 40^\circ\text{C}$ and ordinate $P_S = 15$ kW, point on the graph, it comes in the area marked with CSU 20. This means that the suitable system is, in fact, the CSU 20.

The hydraulic connection of the auxiliary cooling system must be done so as to intake the oil (and any detritus) from the lowest point (point (3) in the assembly positions figures) and have the delivery from a point far enough away from the intake to facilitate changing the oil from inside the reduction gear. If the intake hole is not big enough to get rid of the pump's flow, two or more intake points must be foreseen to guarantee against the risk of cavitation. Two or more connection holes may also be used for delivery, for example, in the case of multi-stage reduction gears.

Beispiel

Ein zusätzliches Kühlsystem soll darauf ausgelegt werden, eine Wärmeleistung von $P_S = 15$ kW von einem Planetengetriebe abzuleiten, das mit einer Betriebstemperatur von 60°C und bei einer Umgebungstemperatur von 20°C läuft.

Es wird ein Punkt mit der X-Koordinate $\Delta t = 60 - 20 = 40^\circ\text{C}$ und der Y-Koordinate $P_S = 15$ kW, ermittelt, der im Bereich CSU 20 liegt. Am besten geeignet ist damit das System CSU 20.

Der Hydraulikanschluss vom zusätzlichen Kühlsystem muss so erfolgen, dass das Öl (mit eventuellen Verunreinigungen) an der am weitesten unten liegenden Stelle (Punkt (3) auf den Abbildungen mit der Montageposition) angesaugt und die Druckleitung an einer Stelle angelegt wird, die sich in ausreichender Entfernung von der Ansaugleitung befindet, um den Ölaustausch im Planetengetriebe zu fördern. Sollte die Ansaugöffnung nicht groß genug sein, um den Durchsatz der Pumpe zu bedienen, müssen zwei oder mehr Ansaugstellen vorgesehen werden, um Hohlsockbildung zu vermeiden. Auch für die Druckleitung können zwei oder mehr Anschlüsse vorgesehen werden, zum Beispiel bei mehrstufigen Planetengetrieben.

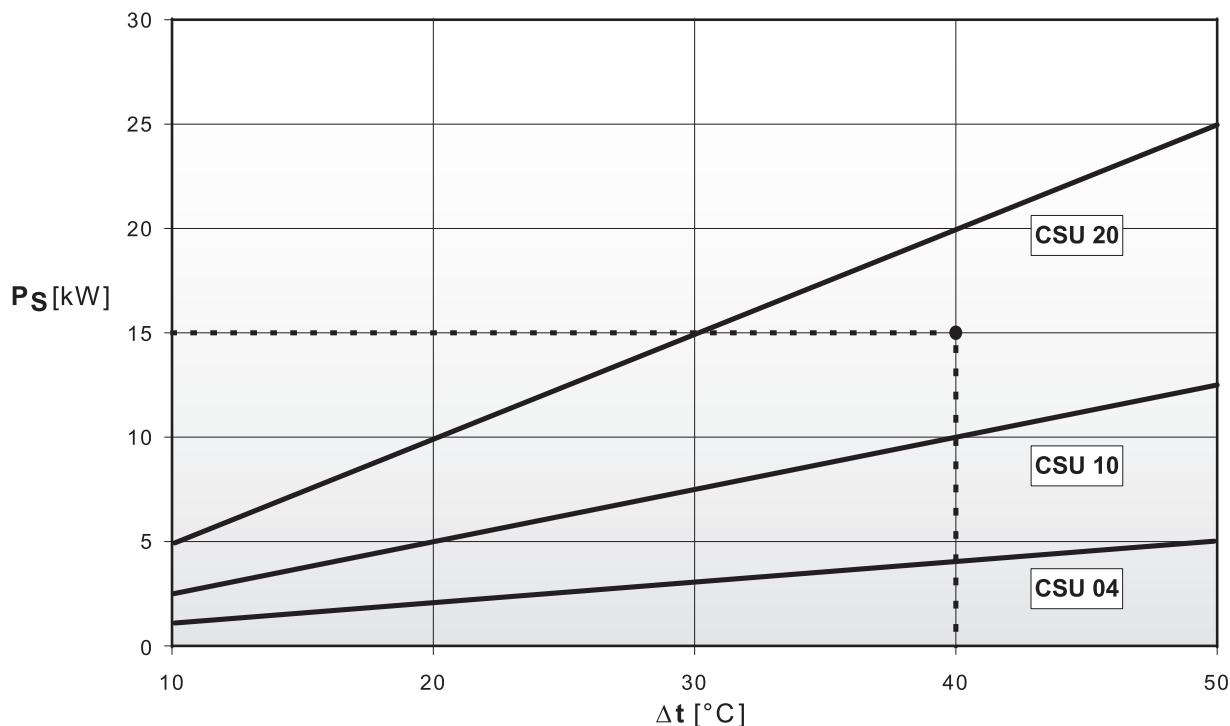
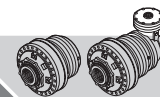

Exemple

Il faut dimensionner un système auxiliaire de refroidissement pour évacuer une puissance thermique $P_S = 15 \text{ kW}$ d'un réducteur qui fonctionne à la température de fonctionnement de 60°C ., à une température ambiante de 20°C .

En prenant sur le graphique le point d'abscisse $\Delta t = 60 - 20 = 40^\circ\text{C}$ et d'ordonnée $P_S = 15 \text{ kW}$, cela tombe dans la zone indiquée par CSU 20. Le système adéquat est donc bien le CSU 20.

Le raccordement hydraulique du système auxiliaire de refroidissement doit être fait de manière à aspirer l'huile (et tout déchet éventuel) du point le plus bas (indiqué par (3) sur les figures des positions de montage) et effectuer le refoulement d'un point suffisamment distant de l'aspiration, de manière à faciliter le rechange d'huile dans le réducteur. Si la dimension du trou d'aspiration est insuffisante pour évacuer le débit de la pompe, il faut prévoir deux points d'aspiration ou plus, de manière à prévenir le risque de cavitation. Pour le refoulement aussi, il est possible d'utiliser deux trous de raccordement ou plus, par exemple avec des réducteurs multi-étages.

Ejemplo

Se debe dimensionar un sistema auxiliar de refrigeración para eliminar una potencia térmica $P_S = 15 \text{ kW}$ de un reductor que trabaja a la temperatura de funcionamiento de 60°C , con temperatura ambiente de 20°C .

Individuando en el gráfico el punto de abscisa $\Delta t = 60 - 20 = 40^\circ\text{C}$ y ordenada $P_S = 15 \text{ kW}$, éste queda en la zona indicada con CSU 20. Por lo tanto el sistema idóneo es precisamente el sistema CSU 20.

El conexionado hidráulico del sistema auxiliar de refrigeración se debe realizar de manera que se aspire el aceite (y eventuales detritos) desde el punto más bajo (punto (3) en las figuras de las posiciones de montaje) y efectuar la impulsión desde un punto suficientemente distante de la aspiración, a fin de facilitar el recambio de aceite dentro del reductor. Si las medidas del agujero de aspiración fuesen insuficientes para tratar el caudal de la bomba, es preciso prever dos o más puntos de aspiración, a fin de evitar el riesgo de cavitación. También para la impulsión se pueden utilizar dos o más agujeros de conexión, por ejemplo en el caso de reductores multi-etapa.

Exemplo

Deve-se dimensionar um sistema auxiliar de arrefecimento para eliminar uma potência térmica $P_S = 15 \text{ kW}$ de um reductor que trabalha à temperatura de exercício de 60°C , com temperatura ambiente de 20°C .

Individuando no gráfico o ponto de abscissa $\Delta t = 60 - 20 = 40^\circ\text{C}$ e ordenada $P_S = 15 \text{ kW}$, o mesmo cai na zona indicada com CSU 20. Portanto o sistema idóneo é mesmo o CSU 20.

A ligação hidráulica do sistema auxiliar de arrefecimento deve ser efetuado de modo a aspirar o óleo (e eventuais detritos) do ponto mais baixo (ponto (3) nas figuras das posições de montagem) e efetuar a ida de um ponto suficientemente distante da aspiração, de modo a facilitar a troca do óleo no interior do reductor. No caso em que a dimensão do furo de aspiração seja insuficiente para tratar o caudal da bomba, é necessário prever dois ou mais pontos de aspiração, de modo da eliminar o perigo de cavitação. Também para o percurso de ida podem ser usados dois ou mais furos de ligação, por exemplo no caso de reductores multi-estádio.

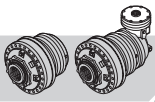

In figura sono riportati alcuni esempi di collegamento del sistema ausiliario di raffreddamento al riduttore, in cui sono mostrati i collegamenti idraulici di aspirazione e mandata e i collegamenti elettrici dei termostati che regolano il funzionamento del sistema.

Il dimensionamento della tubazione di mandata deve tenere conto della distanza tra unità di raffreddamento e riduttore, avendo cura di non superare, nel campo di temperatura di esercizio ($30^{\circ}\text{C} \div 90^{\circ}\text{C}$), una caduta di pressione complessiva della linea di $2 \div 3$ bar.

The figure gives a few examples of connecting the auxiliary cooling system to the reduction gear, where you can see the intake and delivery hydraulic connections as well as the electrical connections of the thermostats that regulate system operation.

The size of the delivery pipes must take into account the distance between the cooling unit and the reduction gear, being careful not to exceed an overall line pressure drop of $2 \div 3$ bar in the operating temperature range ($30^{\circ}\text{C} \div 90^{\circ}\text{C}$).

Die Abbildung zeigt einige Anschlussbeispiele vom Kühlsystem an das Planetengetriebe mit Angabe der Hydraulikanlüsse von Saug- und Druckleitung und der elektrischen Anschlüsse der Thermostate, die den Betrieb vom Kühlsystem regeln.

Die Auslegung der Druckleitung muss den Abstand zwischen Kühlsystem und Planetengetriebe berücksichtigen. Dabei muss darauf geachtet werden, dass im Bereich der Betriebstemperatur ($30^{\circ}\text{C} \div 90^{\circ}\text{C}$) ein Druckabfall von insgesamt $2 \div 3$ Bar in der Leitung nicht überschritten wird.

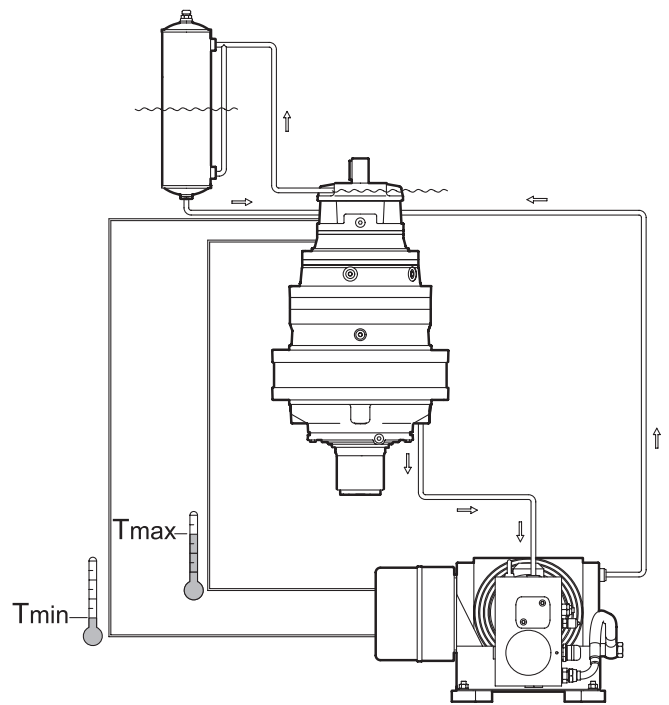
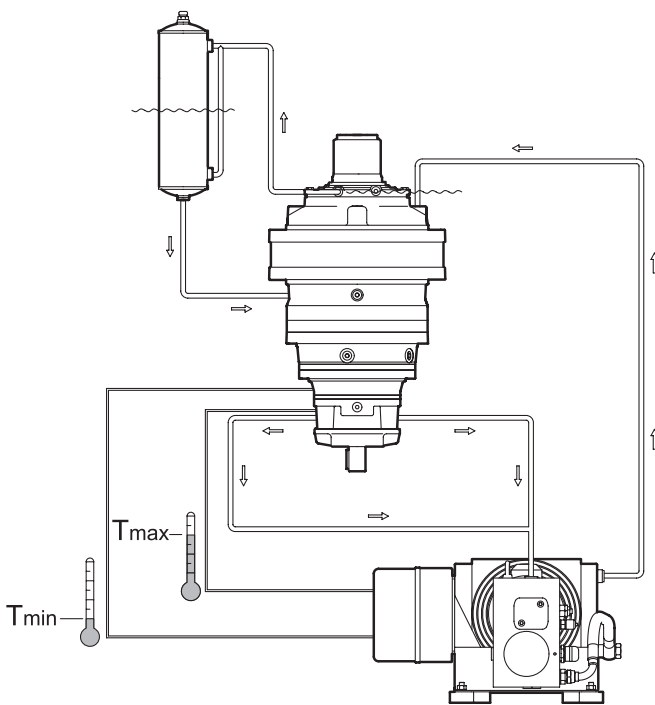
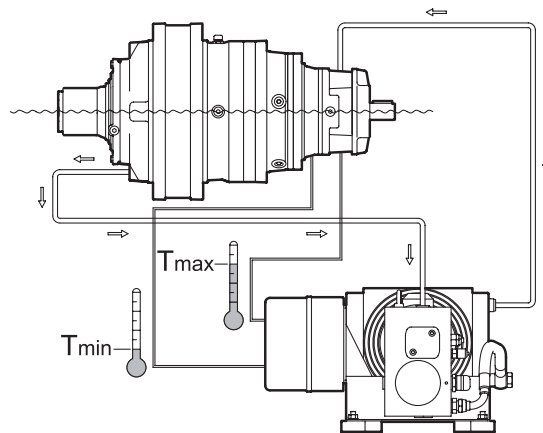

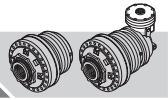

FR ES PT

La figure montre des exemples de raccordement du système auxiliaire de refroidissement au réducteur, où l'on peut voir les raccordements hydrauliques d'aspiration et de refoulement et les branchements électriques des thermostats qui régulent le fonctionnement du système.

Le dimensionnement des tuyaux de refoulement doit tenir compte de la distance entre unité de refroidissement et réducteur, en veillant à ne pas dépasser, sur la plage des températures de fonctionnement ($30^{\circ}\text{C} \div 90^{\circ}\text{C}$), une baisse de pression totale de la ligne de 2÷3 bars.

En la figura se presentan algunos ejemplos de conexión con el reductor del sistema auxiliar de refrigeración, ejemplos en los cuales se muestran las conexiones hidráulicas de aspiración e impulsión y las conexiones eléctricas de los termostatos que regulan el funcionamiento del sistema.

El dimensionamiento de la tubería de impulsión debe tener en cuenta la distancia entre la unidad de refrigeración y el reductor, procurando no superar, en el rango de temperatura de funcionamiento ($30^{\circ}\text{C} \div 90^{\circ}\text{C}$), una caída de presión total de la línea de 2÷3 bar.

Na figura estão indicados alguns exemplos de ligação do sistema auxiliar de arrefecimento ao redutor, no qual estão ilustradas as ligações hidráulicas de aspiração e ida e as ligações elétricas dos termostatos que regulam o funcionamento do sistema.

O dimensionamento da tubagem de ida deve tomar em consideração a distância entre a unidade de arrefecimento e o redutor, prestando atenção para não superar, no campo de temperatura de exercício ($30^{\circ}\text{C} \div 90^{\circ}\text{C}$), uma queda de pressão total da linha de 2÷3 bar.

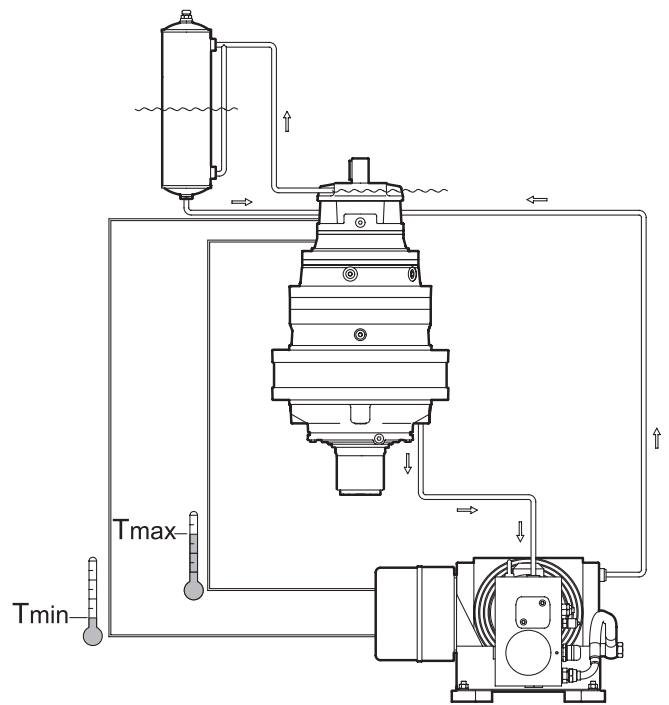
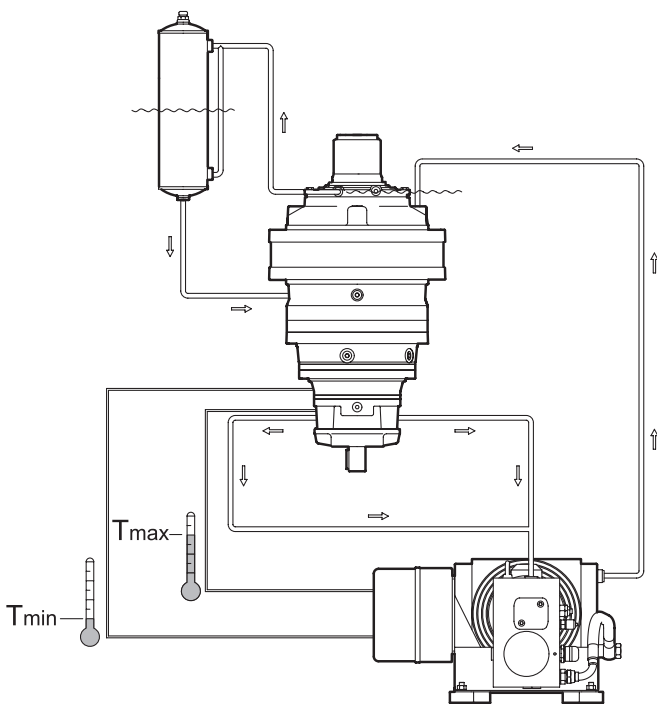
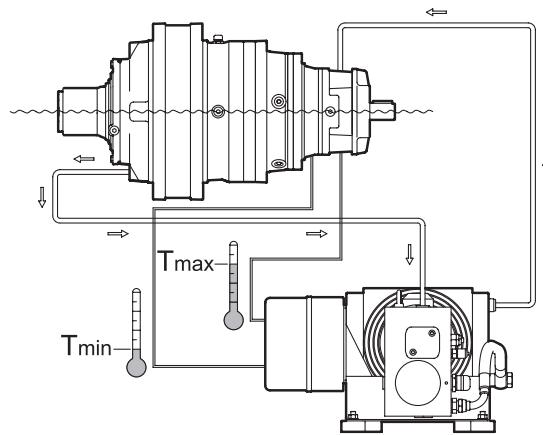

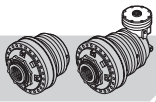

7 IMBALLO, MOVIMENTAZIONE E STOCCAGGIO

I prodotti Reggiana Riduttori vengono imballati e spediti in casse o su pallets. L'imballo è realizzato in maniera da resistere alle condizioni dei normali ambienti industriali. In caso di ambienti particolarmente ostili occorre predisporre opportune misure di protezione.

I riduttori vengono avvolti in sacchi di plastica e, nel caso di imballaggio in casse, viene introdotto del polistirolo o altro materiale per attutire gli urti.

7.1 Movimentazione

Eseguire la movimentazione dei colli con attrezzature e mezzi di sollevamento idonei al tipo di imballo.

Tenere conto della massa, dell'ingombro, dei punti di presa e della posizione del baricentro; questi dati, se necessari, sono indicati esternamente al collo.



La movimentazione deve essere affidata a personale esperto, che operi nel rispetto delle norme antinfortunistica, per garantire la propria sicurezza e quella delle persone presenti nelle vicinanze.

Per la movimentazione attenersi alle seguenti disposizioni:

- individuare un'area con superficie possibilmente piana e sufficientemente grande per contenere i colli, sulla quale effettuare lo scarico;
- non inclinare o capovolgere i colli durante il sollevamento e lo spostamento;
- procedere con cautela durante il posizionamento dei colli, evitando movimenti bruschi ed impatti violenti.

Per la rimozione dei riduttori dal loro imballo, utilizzare accessori idonei (catene, fasce, funi, golfari, ganci, etc.), e fare in modo da avere il carico sempre bilanciato.

7 PACKING, HANDLING AND STORING

Reggiana Riduttori products are packed and shipped in crates or on pallets. Packaging is made to withstand the conditions of normal industrial environments. However, suitable protection measures must be taken if environmental conditions are particularly bad.

The reduction gears are wrapped in plastic bags and, if they're being packed in crates, polystyrene or other similar material is put inside to soften knocks.

7.1 Handling

Handle the packs with equipment and lifting means that are suitable for this type of packaging.

Take into account the mass, dimensions, points for lifting and the barycentre; these data, if necessary, are indicated outside of the pack.

Handling must be entrusted to expert personnel who must work in compliance with the accident prevention rules and regulations so as to guarantee their own safety and that of others in the vicinity.

Follow these instructions for handling:

- *find an area where the surface is flat and possibly big enough for unloading and depositing the packs;*
- *do not tilt or turn the packs upside down when lifting and moving;*
- *proceed with caution when positioning the packs, avoiding sudden movements and violent knocks.*

Use suitable tools to take the reduction gears out of their packaging (chains, straps, ropes, eyebolts, hooks, etc.) and make sure the load is always balanced.

7 VERPACKUNG, TRANSPORT UND LAGERUNG

Die Produkte von Reggiana Riduttori werden in Kisten oder auf Paletten verpackt und ausgeliefert.

Die Verpackung erfolgt so, dass sie den normalen Bedingungen an industriellen Standorten standhält. Bei besonders widrigen Umgebungen müssen entsprechende Schutzmaßnahmen ergriffen werden. Die Planetengetriebe sind mit Plastikplatten geschützt und bei der Verpackung in Kisten werden sie durch Styropor oder ein ähnliches Material gegen Stöße geschützt.

7.1 Transport

Der Transport darf ausschließlich mit geeigneten Hebevorrichtungen durchgeführt werden.

Das Gewicht, die Abmessungen, die Hebepunkte und die Lage vom Schwerpunkt müssen beachtet werden. Entsprechende Angaben befinden sich außen auf der Packung.

Der Transport darf ausschließlich von kompetentem Personal unter Beachtung der geltenden Unfallverhütungsvorschriften vorgenommen werden, um für die Sicherheit vom Personal und aller in der Nähe befindlichen Personen zu garantieren.

Hinweise für den korrekten Transport:

- Das Abladen an einem Ort durchführen, der möglichst eben ist und ausreichend Platz für die Kisten bzw. Paletten bietet;
- Die Kisten bzw. Paletten beim Anheben und Transportieren nicht in eine schräge Position bringen oder kippen;
- Die Kisten bzw. Paletten mit der gebotenen Vorsicht absetzen. Heftige Bewegungen und Stöße vermeiden.

Das Planetengetriebe mit geeigneten Hebevorrichtungen (Ketten, Gurte, Seile, Ringschrauben, Haken, usw.) aus der Kiste nehmen. Sicherstellen, dass sich die Last im Gleichgewicht befindet.



7 EMBALLAGE, MANUTENTION ET STOCKAGE

Les produits Reggiana Riduttori sont emballés et expédiés en caisses ou sur palettes. Tous les produits sont emballés avec des matériaux adaptés pour résister à des environnements industriels normaux. En cas d'atmosphères particulièrement hostiles, prévoir les mesures de protection appropriées.

Les réducteurs sont enveloppés dans un sac en plastique et, dans le cas d'emballage en caisses, ils seront protégés avec du polystyrène ou un autre matériau permettant d'atténuer les chocs.

7.1 Manutention

Exécuter la manutention des colis à l'aide d'engins de levage appropriés au type d'emballage.

Tenir compte de la masse, des dimensions, des endroits de prise et de la position du barycentre; si besoin est, ces données sont indiquées à l'extérieur du colis.



La manutention doit être faite par un personnel qualifié qui travaille dans le respect des règles pour la prévention des accidents, afin de garantir sa propre sécurité et celle des personnes qui l'entourent.

Pour la manutention, se conformer aux dispositions suivantes:

- choisir des locaux dont la surface est plane et suffisamment grande pour contenir les colis, pour effectuer le déchargement;
- ne pas incliner ni renverser les colis au moment du levage et du déplacement;
- faire attention au moment du positionnement des colis; éviter tout mouvement brusque et tout impact violent.

Pour enlever les réducteurs de leur emballage, utiliser des accessoires appropriés (chaînes, courroies, cordes, pitons à œil, crochets, etc.), et faire en sorte que la charge soit toujours équilibrée.

7 EMBALAJE, DESPLAZAMIENTO Y ALMACENAMIENTO

Los productos Reggiana Riduttori son embalados y enviados en cajas o sobre paletas. El embalaje está realizado de manera que resista a las condiciones de los normales ambientes industriales. En caso de ambientes particularmente hostiles es necesario predisponer oportunas medidas de protección.

Los reductores vienen envueltos en sacos de plástico y, en el caso de embalaje en caja, se pone poliestireno u otro material para amortiguar los golpes.

7.1 Desplazamiento

Efectuar el desplazamiento de los bultos utilizando equipos y medios de elevación adecuados para el tipo de embalaje.

Tener en cuenta la masa, las medidas máximas, los puntos de agarre y la posición del baricentro; estos datos, si necesario, vienen indicados al exterior del bulto.

El desplazamiento debe ser confiado a personal experto, que trabaje respetando las normas de prevención de accidentes, para garantizar la propia seguridad y aquella de las personas presentes en las cercanías.

Para el desplazamiento ajustarse a las siguientes disposiciones:

- *individuar un área con una superficie a ser posible plana y suficientemente grande para contener los bultos, sobre la cual efectuar la descarga;*
- *no inclinar ni volcar los bultos durante la elevación y el desplazamiento;*
- *proceder con cautela durante la colocación de los bultos, evitando movimientos bruscos y golpes violentos.*

Para sacar los reductores de su embalaje, utilizar accesorios adecuados (cadenas, eslingas, cables, cáncamos, ganchos, etc.), y procurar tener la carga siempre equilibrada.

7 EMBALAGEM, MOVIMENTAÇÃO E ARMAZENAGEM

Os produtos Reggiana Riduttori são embalados e expedidos em caixas ou sobre paletes. A embalagem é realizada de modo a resistir às condições dos normais ambientes industriais. No caso de ambientes particularmente agressivos é necessário adotar oportunas medidas de proteção.

Os redutores são envolvidos em sacos de plástico e, no caso de embalagem em caixas, é introduzido esferovit ou outro material para atenuar os choques.

7.1 Movimentação

Efetuar a movimentação dos volumes com equipamento e meios de levantamento idóneos ao tipo de embalagem.

Tomar em consideração a massa, o volume, os pontos de tomada e a posição central dos componentes; estes dados, se necessários, estão indicados na parte externa dos volumes.

A movimentação deve ser feita por pessoal competente, que trabalhe no respeito das normas de segurança contra acidentes, para garantir a própria segurança e aquela das pessoas presentes nas proximidades

Para a movimentação respeitar as seguintes disposições:

- Identificar uma área com superfície possivelmente plana e suficientemente grande para conter os volumes e na qual descarregar;
- não inclinar ou voltar os volumes durante o levantamento e a deslocação;
- proceder com cautela durante o posicionamento dos volumes, evitando movimentos bruscos e choques violentos.

Para a extração dos redutores da sua embalagem, utilizar acessórios idóneos (correntes, cintas, cabos, anéis, ganchos, etc.), e proceder de modo a ter sempre a carga sempre bem equilibrada.

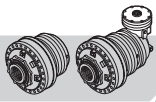

7.2 Stoccaggio

Evitare lo stoccaggio dei riduttori epicycloidali in ambienti aperti o soggetti ad eccessiva umidità; non lasciare mai i riduttori a contatto diretto con il suolo.

Per periodi di stoccaggio superiori a due mesi attenersi alle seguenti indicazioni:

- effettuare il riempimento del riduttore con olio lubrificante del tipo previsto ed orientare il riduttore in modo che il tappo di sfiato sia posto in alto;
- proteggere le superfici esterne di accoppiamento con grasso o con apposito prodotto antiossidante;
- effettuare lo stoccaggio in luogo asciutto e pulito, con temperature comprese tra -15°C e $+50^{\circ}\text{C}$.

7.3 Disimballaggio

Al ricevimento della merce occorre verificare la corrispondenza tra quanto indicato sulla targhetta e le specifiche dell'ordine; verificare, inoltre, che il contenuto dell'imballo non abbia subito danneggiamenti durante il trasporto.

7.4 Smaltimento in sicurezza dei materiali di imballaggio

I materiali che costituiscono l'imballo vanno smaltiti secondo le vigenti norme in materia di ambiente.

7.2 Storing

Do not store the planetary reduction gears in the open or where they would be subject to excessive dampness; never leave the reduction gears in direct contact with the ground.

If storing for more than two months, proceed as follows:

- *fill the reduction gear with lubricant oil of the type foreseen and position the reduction gear so the venting plug is on top;*
- *protect the outside coupling surfaces with grease or a rustproof product;*
- *store in a dry, clean place where the temperature is between -15°C e $+50^{\circ}\text{C}$.*

7.3 Unpacking

When the goods are received they must be checked to see that they correspond to what is specified on the plate and in the order; also check that the contents of the pack have not been damaged during transport.

7.4 Disposing of the packaging materials safely

The packaging materials must be disposed of in accordance with the current environmental protection laws.

7.2 Lagerung

Die Planetengetriebe nicht im Freien oder an Orten mit hoher Luftfeuchtigkeit lagern. Die Planetengetriebe auf keinen Fall direkt auf dem Boden ablegen.

Bei Lagerung über einen Zeitraum von mehr als zwei Monaten folgende Anweisungen beachten:

- Das Schmieröl vom empfohlenen Typ in das Planetengetriebe füllen und dieses so abstellen, dass die Entlüftungsdeckel nach oben zeigen.
- Die Außenseite vom Planetengetriebe mit Schmierfett oder einem geeigneten Rostschutzmittel schützen;
- Das Planetengetriebe an einem trockenen, sauberen Ort bei einer Temperatur von -15°C bis $+50^{\circ}\text{C}$ lagern.

7.3 Entnahme aus der Verpackung

Beim Empfang der Ware die Übereinstimmung der Angaben auf dem Typenschild mit den Spezifikationen der Bestellung überprüfen. Sicherstellen, dass der Inhalt der Verpackung während des Transports nicht beschädigt wurde.

7.4 Sichere Entsorgung der Verpackungsmaterialien

Die Verpackungsmaterialien müssen unter Beachtung der geltenden Umweltschutzbestimmungen entsorgt werden.

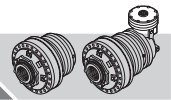

7.2 Stockage

Eviter de stocker les réducteurs épicycloïdaux dans des endroits ouverts ou sujets à un taux d'humidité excessif; ne pas laisser les réducteurs au contact direct du sol.

Pour des périodes de stockage de plus de deux mois, se conformer aux indications suivantes.

- effectuer le nourrissage du réducteur avec de l'huile de lubrification du type prévu et orienter le réducteur de manière que le bouchon d'évent soit positionné vers le haut;
- protéger les surfaces extérieures d'accouplement avec de la graisse ou un produit spécial anti-oxydant;
- effectuer le stockage dans un endroit sec et propre et dont les températures sont comprises entre -15°C et +50°C.

7.3 Décaissement

Lors de la réception de la marchandise, contrôler si la fourniture correspond bien aux indications qui figurent sur la plaque et sur la commande; vérifier aussi si le contenu de l'emballage a été endommagé pendant le transport.

7.4 Élimination en toute sécurité des matériaux composant l'emballage

Les matériaux qui composent l'emballage doivent être éliminés conformément aux normes pour la protection de l'environnement en vigueur dans le pays où la machine est installée.

7.2 Almacenamiento

Evitar almacenar los reductores epicicloidales al aire libre o en lugares con una excesiva humedad; no dejar nunca los reductores en contacto directo con el suelo.

Para periodos de almacenamiento de más de dos meses, ajustarse a las siguientes indicaciones:

- *efectuar el llenado del reductor con aceite lubricante del tipo previsto y orientar el reductor de manera que el tapón de purga quede en la parte alta;*
- *proteger las superficies externas de acoplamiento con grasa o con un adecuado producto antioxidante;*
- *efectuar el almacenamiento en un lugar seco y limpio, con temperaturas entre -15°C e +50°C.*

7.3 Desembalaje

Al recibir la mercancía es necesario comprobar que se corresponda cuanto indicado en la placa con las especificaciones del pedido; comprobar así mismo que el contenido del embalaje no haya sufrido daños durante el transporte

7.4 Eliminación segura de los materiales de embalaje

Los materiales que componen el embalaje deben eliminarse conforme a las normas vigentes en materia de medio ambiente.

7.2 Armazenagem

Evitar a armazenagem dos redutores epicicloidais em ambientes ao ar livre ou sujeitos a excessiva umidade; nunca deixar os redutores em contato direto com o chão.

Por períodos de armazenagem superiores a dois meses respeitar as seguintes instruções:

- efetuar o enchimento do redutor com óleo lubrificante do tipo previsto e regular o redutor de modo que o tampão de resfolgo fique voltado para cima.
- proteger as superfícies externas de acoplamento com graxa ou com produto específico anti-oxidante;
- efetuar a armazenagem em lugar enxuto e limpo, com temperaturas compreendidas entre -15°C e + 50°C.

7.3 Retiro da embalagem

À recepção da mercadoria é necessário verificar a correspondência entre quanto indicado na placa contendo os dados técnicos e as especificações constantes na ordem; verificar, também, que o conteúdo da embalagem não tenha sofrido danos durante o transporte.

7.4 Eliminação em segurança dos materiais de embalagem

Os materiais que constituem a embalagem devem ser eliminados de acordo com quanto estabelecido pelas normas vigentes em matéria de proteção do ambiente.

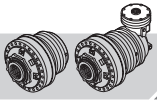

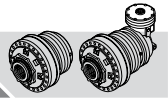

B

Dati tecnici e dimensionali
Technical and size data
Technische daten und Abmessungen
Données techniques et dimensionnelles
Datos técnicos y dimensionales
Dados técnicos e dimensões

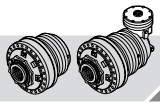

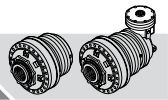

Grandezza / Size / Größe Grandeur / Talla / Grandeza	T_{2n} [Nm]	Pag. / Page / Seite Page / Pag. / Pag.
RR2500	25000	B-4
RR3200	33000	B-20
RR4000	40000	B-36
RR5200	52000	B-52
RR6500	68000	B-68
RR8000	80000	B-84
RR10000	100000	B-100
RR15000	150000	B-116
RR20000	210000	B-126
RR25000	280000	B-134
RR30000	320000	B-142
RR40000	420000	B-150
RR55000	560000	B-158



RR2500

IT EN DE FR ES PT

RR2500 L.. .. **i**



	i	T ₂ [Nm]						n _{1max} [min ⁻¹]	T _{2max} [Nm]	P _t [kW]
		n ₂ x h								
		10000 (10 ⁴)	25000 (2.5 · 10 ⁴)	50000 (5 · 10 ⁴)	100000 (10 ⁵)	500000 (5 · 10 ⁵)	1000000 (10 ⁶)			
RR2500 L1	4.00	29900	27820	25110	23000	19520	15860	2000	37000	38
	4.71	26350	23210	20210	19060	17270	15560	2000	37000	38
	5.85	20100	16730	14870	14250	12910	12370	2000	37000	38
RR2500 L2	15.69	29900	27820	25110	23000	18460	15000	3000	37000	23
	17.22	29900	27820	25110	23000	18200	14780	3000	37000	23
	21.88	24540	21800	20890	20030	17710	14380	3000	37000	23
	25.74	26350	23210	20210	19060	17270	15560	3000	37000	23
	30.25	20480	19130	18330	17570	15920	15260	3000	37000	23
	37.58	20100	16730	14870	14250	12910	12370	3000	37000	23
	46.24	16280	15390	14750	14140	12810	12280	3000	37000	23
	50.28	16300	15400	14750	14130	12800	12260	3000	37000	23
RR2500 L3	53.35	29900	27820	25110	23000	18460	15000	3500	37000	17
	62.77	29900	27820	25110	23000	18460	15000	3500	37000	17
	68.87	29900	27820	25110	23000	18200	14780	3500	37000	17
	86.09	26640	25180	24130	23000	18200	14780	3500	37000	17
	99.86	23560	22280	21360	20480	18200	14780	3500	37000	17
	109.41	24540	21800	20890	20030	17710	14380	3500	37000	17
	126.92	24540	21800	20890	20030	17710	14380	3500	37000	17
	149.31	26350	23210	20210	19060	17270	15560	3500	37000	17
	180.21	24520	23190	20210	19060	17270	15560	3500	37000	17
	211.76	20480	19130	18330	17570	15920	15260	3500	37000	17
	263.08	20100	16730	14870	14250	12910	12370	3500	37000	17
	323.66	16280	15390	14750	14140	12810	12280	3500	37000	17
	351.94	16300	15400	14750	14130	12800	12260	3500	37000	17
	RR2500 L4	245.62	29900	27820	25110	23000	18460	15000	3500	37000
289.25		29900	27820	25110	23000	17850	14500	3500	37000	13
340.30		29900	27820	25110	23000	18200	14780	3500	37000	13
398.46		29900	27820	25110	23000	18200	14780	3500	37000	13
498.07		26640	25180	24130	23000	18200	14780	3500	37000	13
610.43		26640	25180	24130	23000	18200	14780	3500	37000	13
708.10		23560	22280	21360	20480	18200	14780	3500	37000	13
775.83		24540	21800	20890	20030	17710	14380	3500	37000	13
899.96		24540	21800	20890	20030	17710	14380	3500	37000	13
1058.78		26350	23210	20210	19060	17270	15560	3500	37000	13
1277.84		24520	23190	20210	19060	17270	15560	3500	37000	13
1501.60		20480	19130	18330	17570	15920	15260	3500	37000	13
1639.34		16280	15390	14750	14140	12810	12280	3500	37000	13
1865.45		20100	16730	14870	14250	12910	12370	3500	37000	13
2295.07		16280	15390	14750	14140	12810	12280	3500	37000	13
2495.56		16300	15400	14750	14130	12800	12260	3500	37000	13



RR2500

A..

..

i



i	T ₂ [Nm]						n _{1max} [min ⁻¹]	T _{2max} [Nm]	P _t [kW]	
	n ₂ x h									
	10000 (10 ⁴)	25000 (2.5 · 10 ⁴)	50000 (5 · 10 ⁴)	100000 (10 ⁵)	500000 (5 · 10 ⁵)	1000000 (10 ⁶)				
RR2500 A2 (A)	10.91	24420	24420	20490	16640	10270	8340	2500	37000	34
	12.83	26350	23210	20210	18650	11510	9350	2500	37000	34
	15.53	24990	23210	20210	17960	11080	9000	2500	37000	34
	18.30	22510	22510	20210	16950	10460	8490	2500	37000	34
	19.29	20100	16730	14870	14250	12900	10470	2500	37000	34
	22.74	20100	16730	14870	14250	12170	9890	2500	37000	34
(B)	11.08	28090	27130	24330	19760	12200	9910	2500	37000	38
	13.03	26350	23210	20210	19060	13660	11100	2500	37000	38
	14.90	26350	23210	20210	19060	13840	11240	2500	37000	38
	19.25	22240	22030	20210	19060	13750	11170	2500	37000	38
	23.92	20100	16730	14870	14250	12910	12370	2500	37000	38
(C)	9.85	29900	27820	25110	23000	19520	15860	2000	37000	50
	12.67	29900	27820	25110	23000	19520	15860	2000	37000	50
	15.27	29900	27820	25110	23000	19520	15860	2000	37000	50
	17.97	26350	23210	20210	19060	17270	15560	2000	37000	50
	22.32	20100	16730	14870	14250	12910	12370	2000	37000	50
RR2500 A3	42.25	29900	26220	21300	17300	10670	8670	3500	37000	20
	46.35	29900	27820	22730	18460	11390	9250	3500	37000	20
	54.30	28840	27560	22380	18180	11220	9110	3500	37000	20
	58.91	24540	21800	20890	20030	13470	10940	3500	37000	20
	69.01	24540	21800	20890	20030	13270	10780	3500	37000	20
	81.19	26350	23210	20210	19060	14870	12080	3500	37000	20
	87.53	24540	21800	20890	20030	12710	10320	3500	37000	20
	95.41	20480	19130	18330	17570	15920	13520	3500	37000	20
	102.98	26350	23210	20210	19060	14240	11570	3500	37000	20
	121.01	20480	19130	18330	17570	15920	12950	3500	37000	20
	150.33	20100	16730	14870	14250	12910	12370	3500	37000	20
	184.95	16280	15390	14750	14140	12810	12280	3500	37000	20
	201.11	16300	15400	14750	14130	12800	12260	3500	37000	20
RR2500 A4	121.95	25820	19620	15930	12940	7990	6490	3500	37000	15
	157.42	29900	23460	19050	15480	9550	7760	3500	37000	15
	196.77	26640	25180	22270	18090	11160	9070	3500	37000	15
	202.26	29900	23280	18910	15360	9480	7700	3500	37000	15
	221.91	29900	24840	20180	16390	10110	8210	3500	37000	15
	250.08	24540	21800	20890	20030	13200	10720	3500	37000	15
	277.39	26640	25180	23590	19160	11820	9600	3500	37000	15
	290.10	24540	21800	20890	20030	14650	11900	3500	37000	15
	321.77	23560	22280	21360	20480	13120	10650	3500	37000	15
	352.55	24540	21800	20890	20030	13980	11360	3500	37000	15
	408.96	24540	21800	20890	20030	15510	12600	3500	37000	15
	481.13	26350	23210	20210	19060	17270	14120	3500	37000	15
	580.67	24520	23190	20210	19060	17270	15560	3500	37000	15
	682.35	20480	19130	18330	17570	15920	15260	3500	37000	15
	879.30	26350	23210	20210	19060	14340	11650	3500	37000	15
	1061.22	24520	23190	20210	19060	16350	13280	3500	37000	15
	1247.06	20480	19130	18330	17570	15920	14870	3500	37000	15
	1549.23	20100	16730	14870	14250	12910	12370	3500	37000	15
	1906.02	16280	15390	14750	14140	12810	12280	3500	37000	15
	2072.53	16300	15400	14750	14130	12800	12260	3500	37000	15



RR2500

IT EN DE FR ES PT

RR2500 L.. .. i



MS MC FS MH 191 RR2500 L1

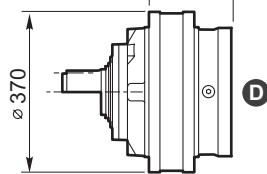

MS MC FS MH 284 RR2500 L2

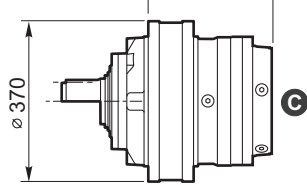

MS MC FS MH 352 RR2500 L3

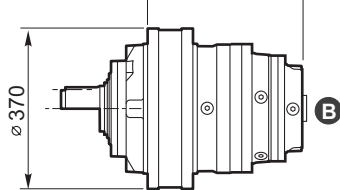

MS MC FS MH 420 RR2500 L4

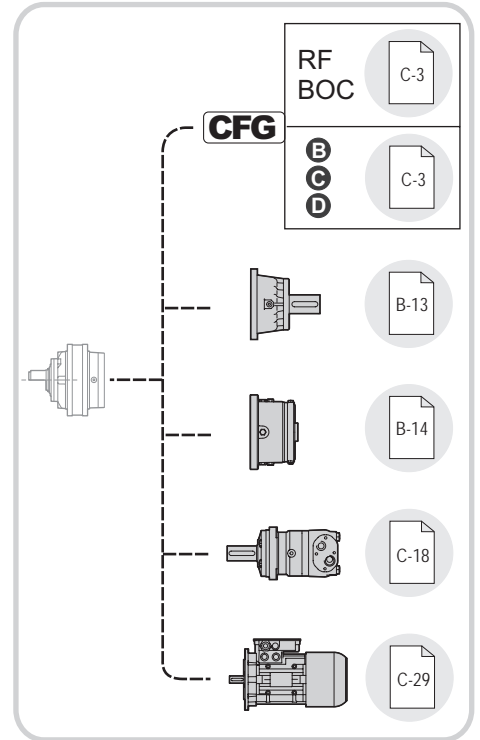
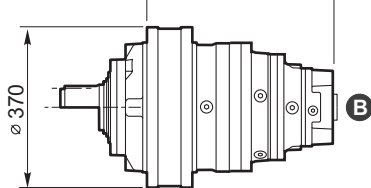

ZI 284 RR2500 L2

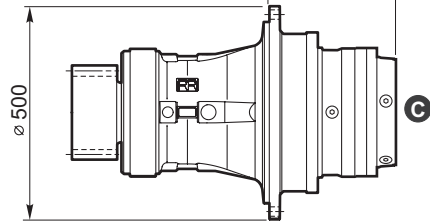

ZI 352 RR2500 L3

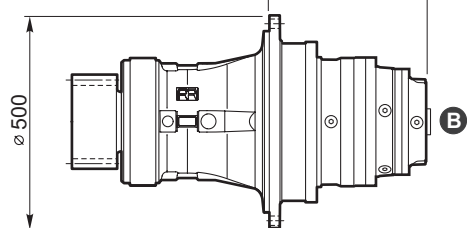

ZI 420 RR2500 L4

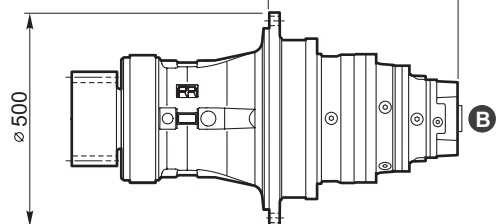

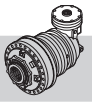

RR2500 A.. .. i

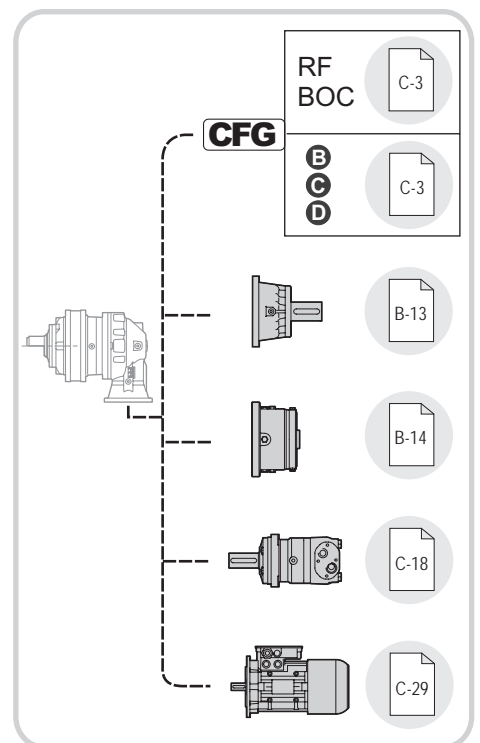
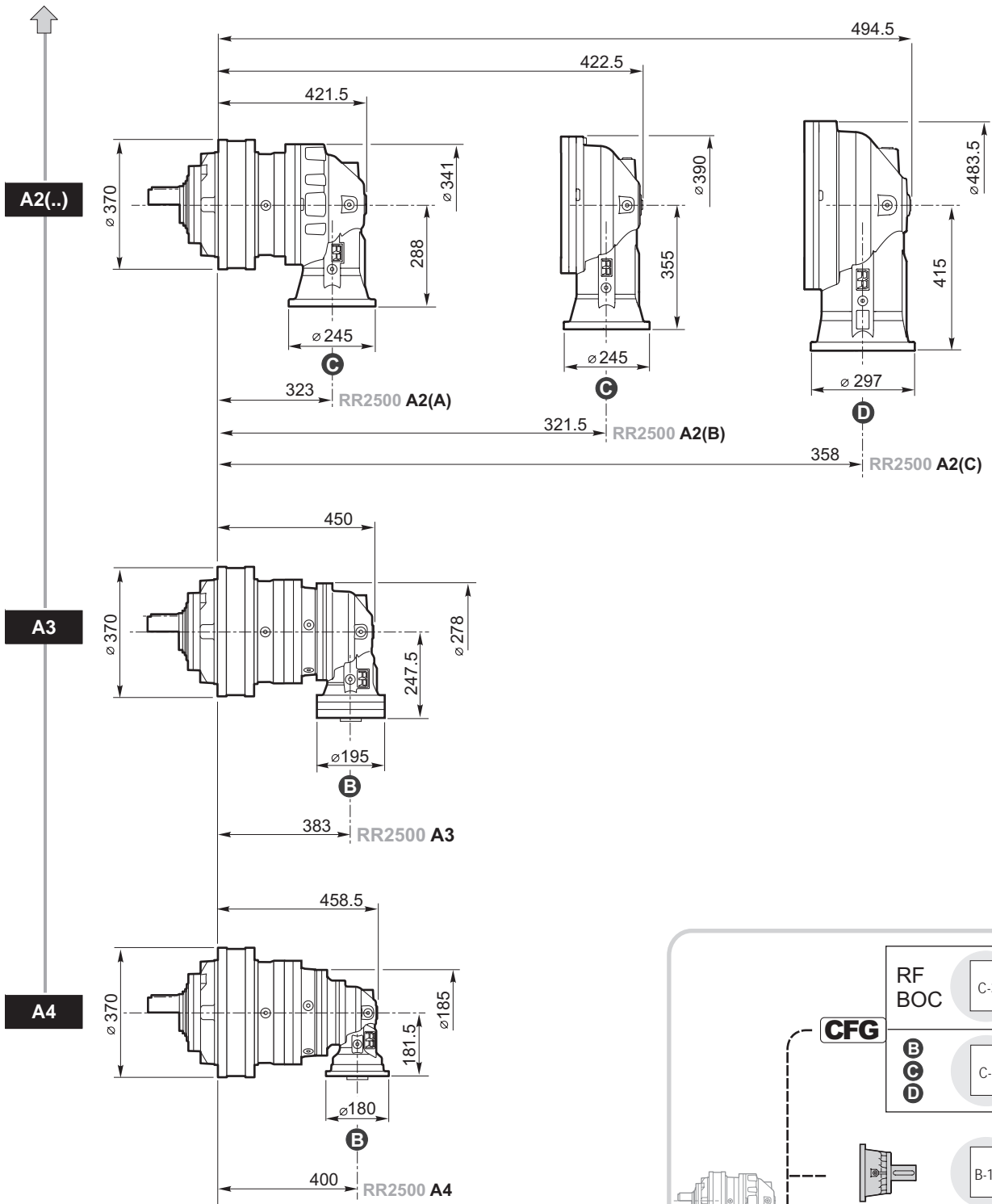

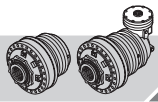

RR2500

IT EN DEFRES PT

RR2500	L..	MS	i
RR2500	A..		i

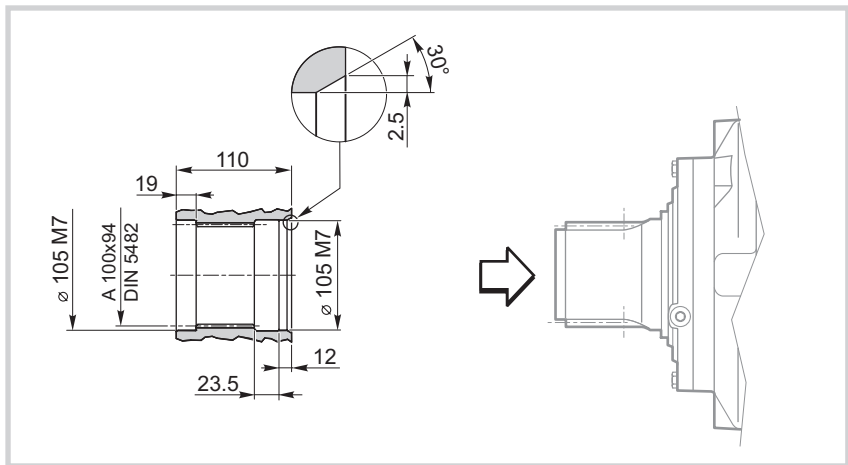
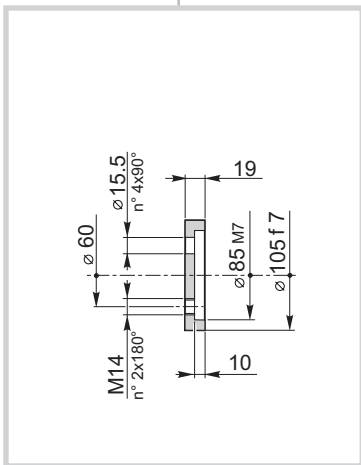
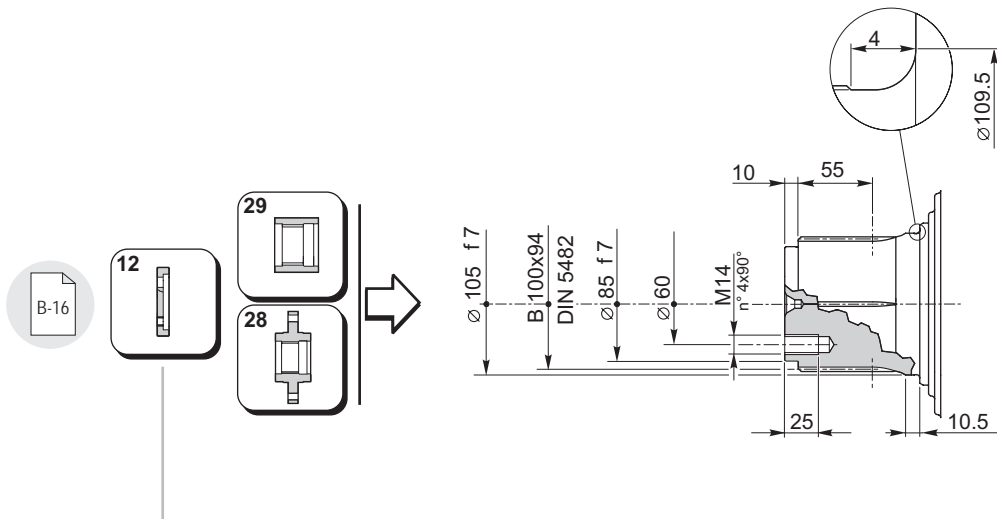
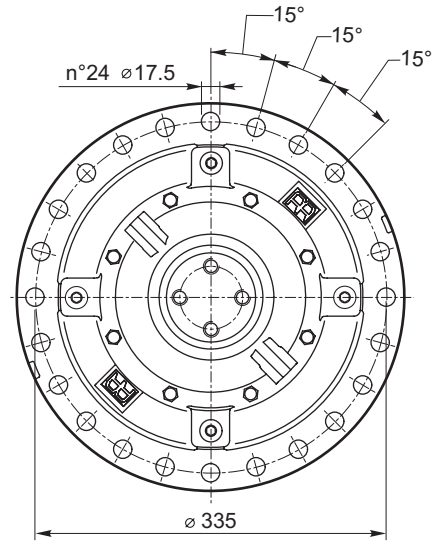
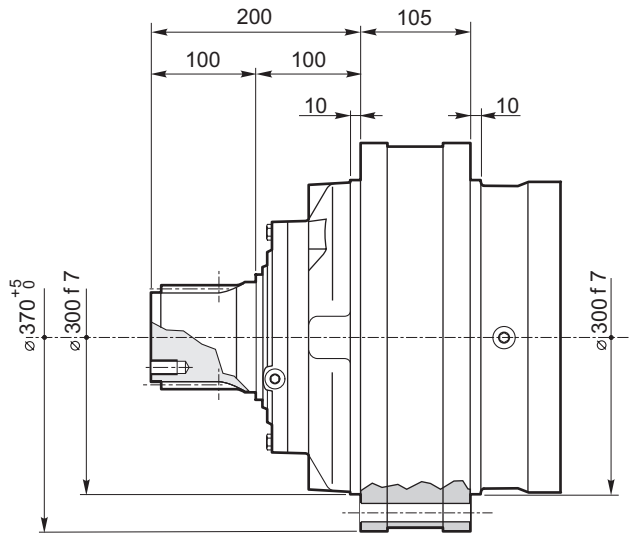

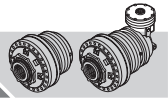

RR2500	L..	MC	i
RR2500	A..		i

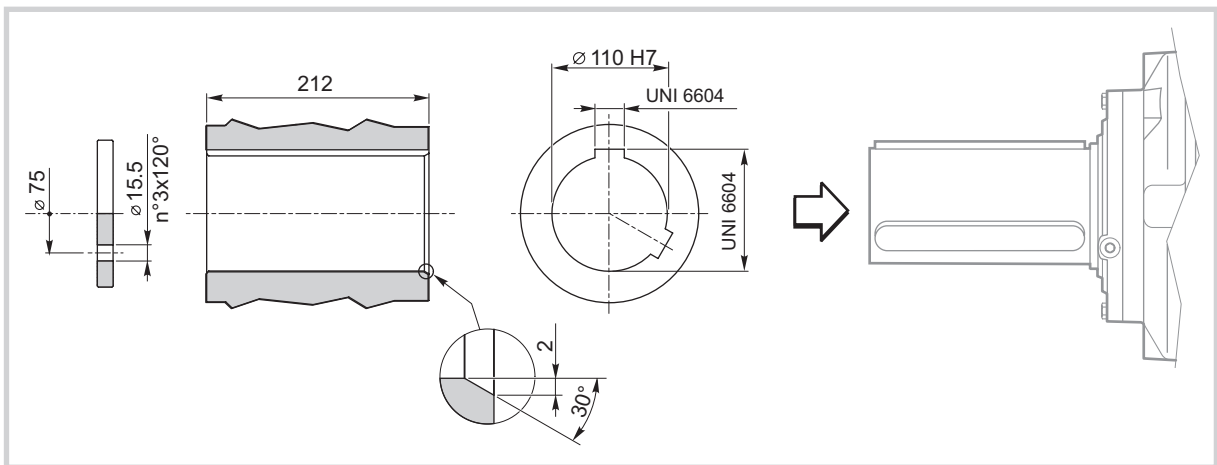
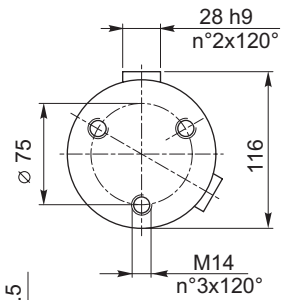
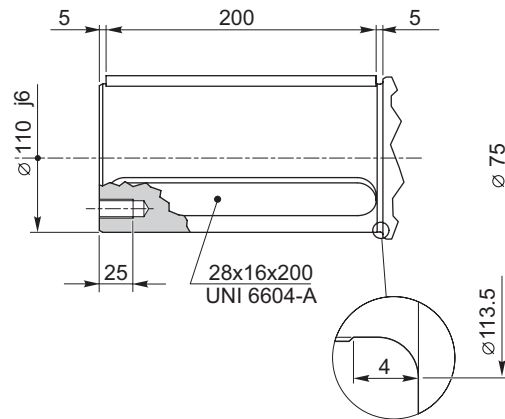
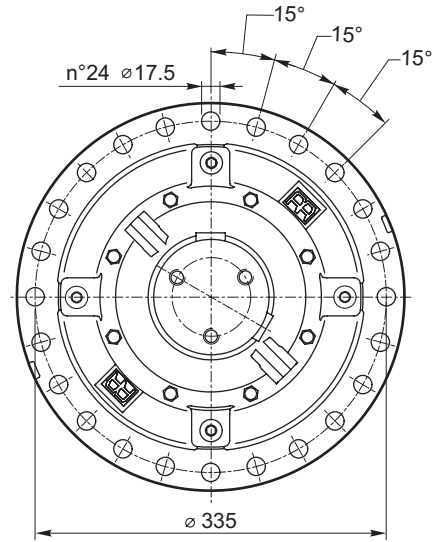
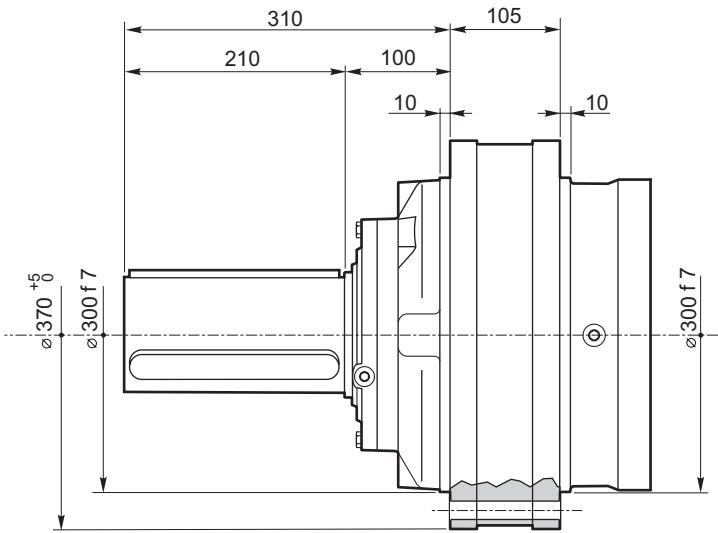

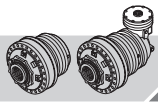

RR2500

IT EN DEFRES PT

RR2500	L..	FS	i
RR2500	A..		i

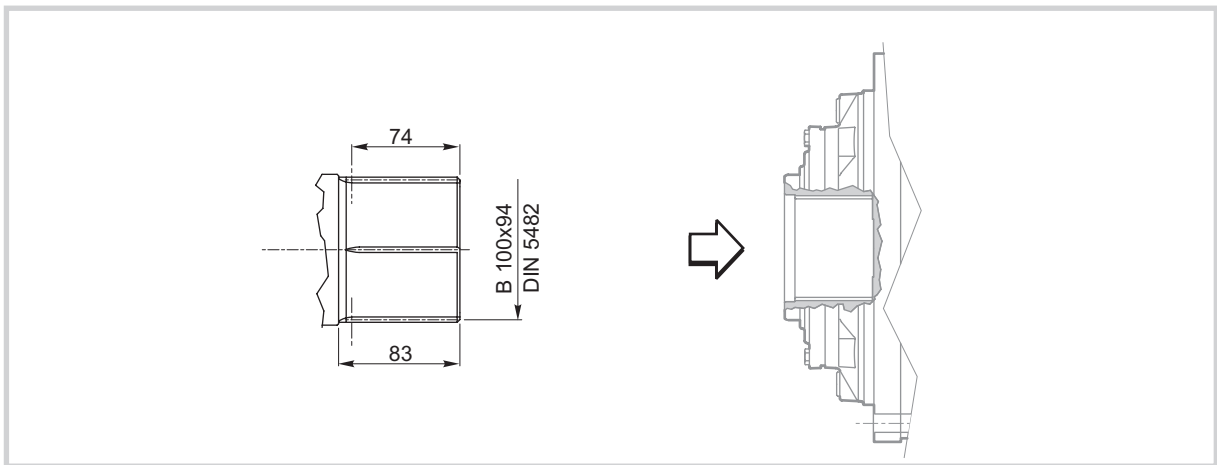
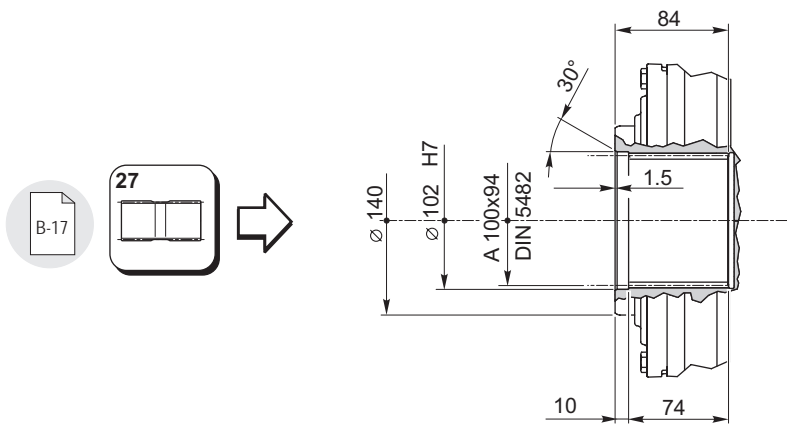
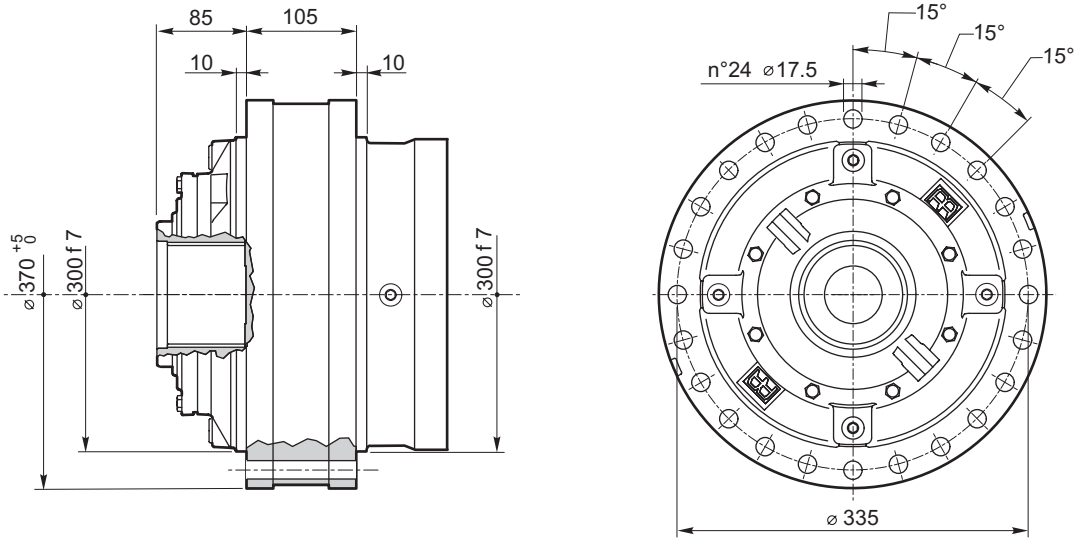

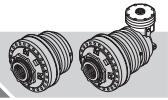

RR2500	L..	MH	i
RR2500	A..		i

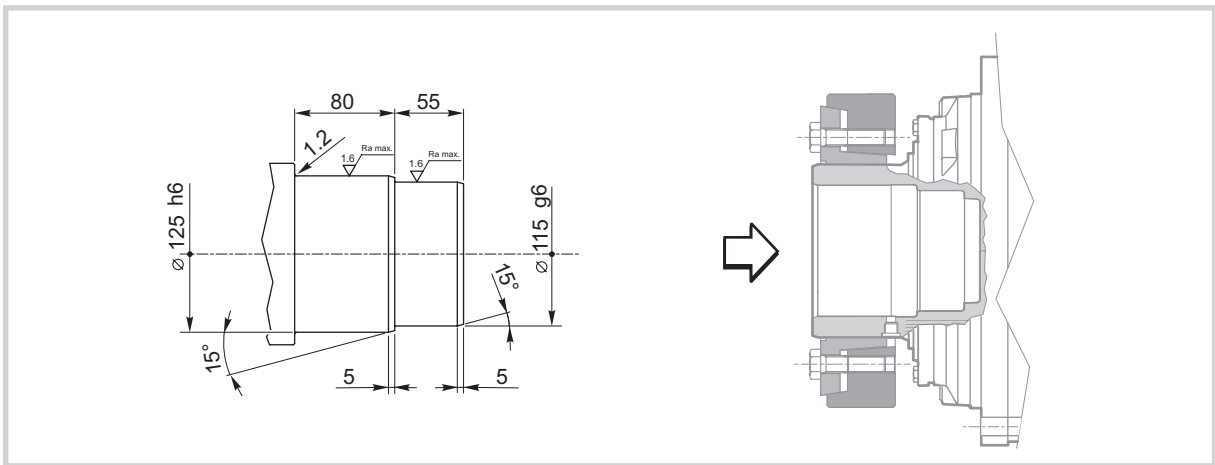
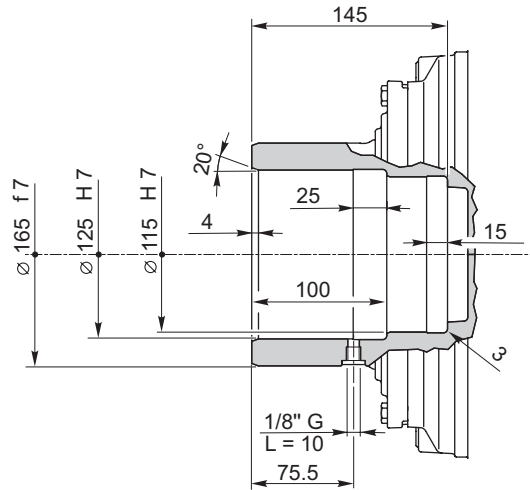
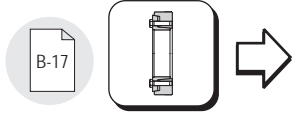
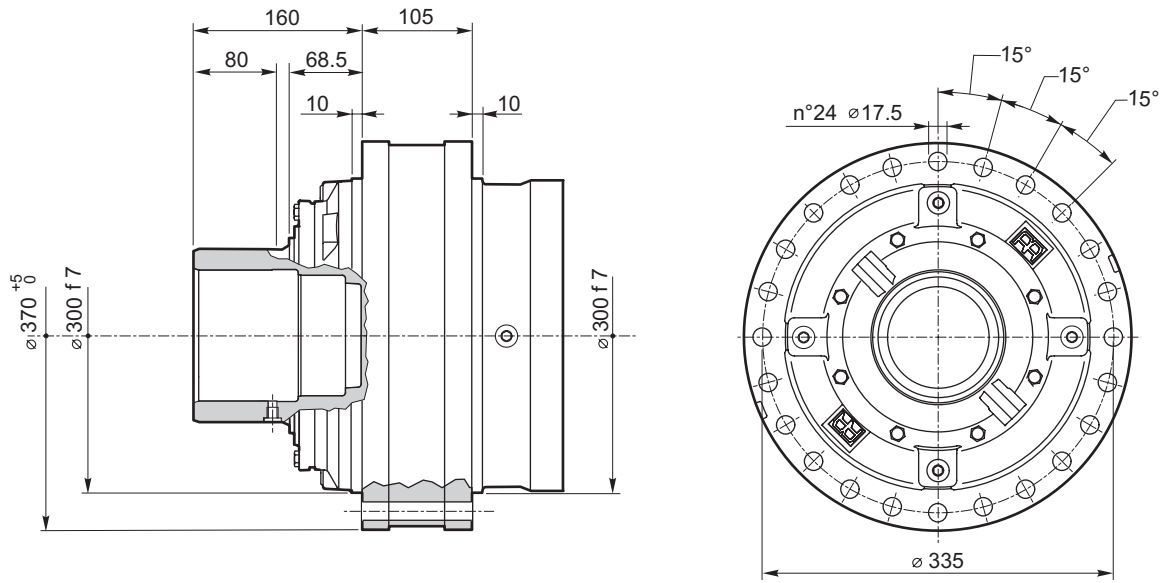



RR2500

IT EN DE FR ES PT

RR2500 L.. ZI i

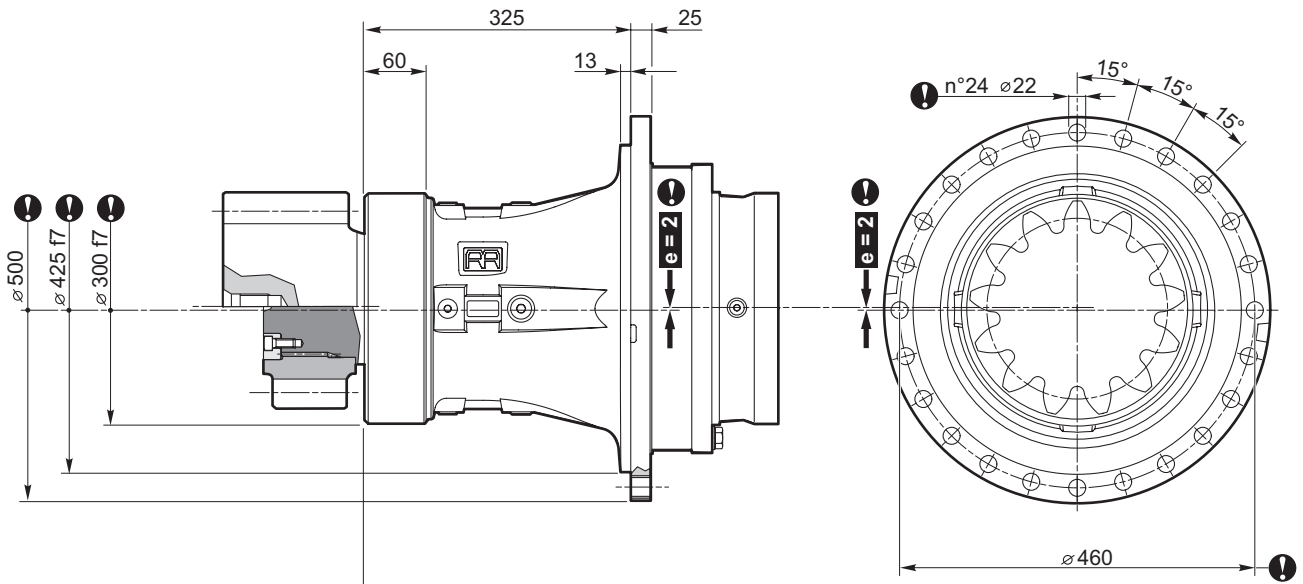

⚠ Quote riferite all'asse con eccentricità "e"
 Dimensions that refer to the axis with "e" eccentricity
 Quoten beziehen sich auf die Achse mit Ausmittigkeit "e"
 Cotes se rapportant à l'axe avec excentricité "e"
 Quotas referidas ao eixo com excentricidade "e"
 Cotas referidas al eje con excentricidad "e"

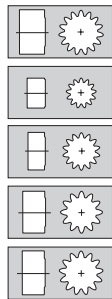
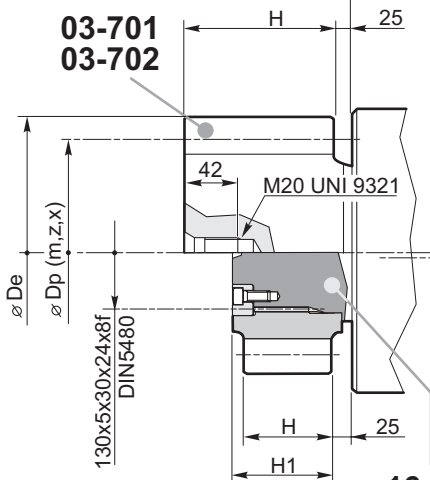

m	z	x	H	H1	Dp	De	code
16	15	0.3125	160	—	240	282	03-701
12	13	0.5	110	—	156	190	03-702
14	14	0.5	105	114.5	196	238	16-245
18	12	0.5	140	140	216	265	16-247
18	13	0.4	140	140	234	279	16-248

16-245
 16-247
 16-248

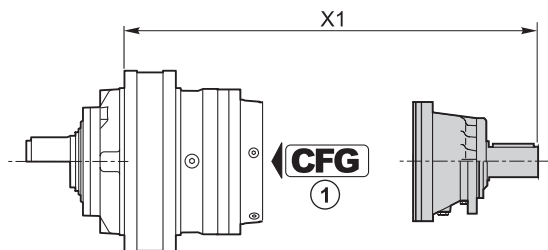
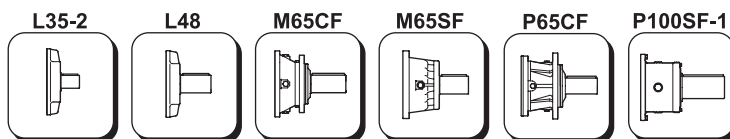

	CFG ①		code	X1
RR2500 L1	—	P100SF-1	154F3322	567.5
RR2500 L2	—	P65CF	154-2404	596
RR2500 L3	RF	M65SF	154B4249	536.5
	RF	M65CF	154-2407	559.5
	BOC	L48	154B3989	473.5
RR2500 L4	BOC	L35-2	154-2190M1	509.5

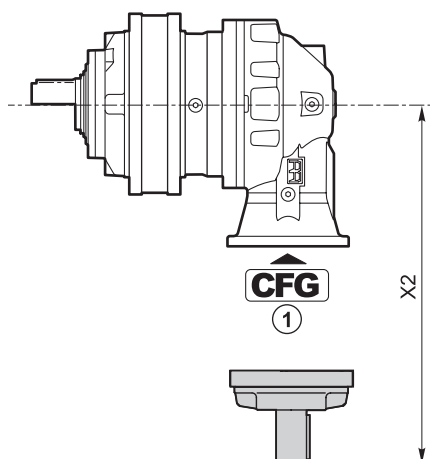

	CFG ①		code	X2
RR2500 A2(A)	—	P65CF	154-2404	600
RR2500 A2(B)	—	P65CF	154-2404	667
RR2500 A2(C)	—	P100SF-1	154F3322	791.5
RR2500 A3	BOC	L48	154B3989	348
RR2500 A4	BOC	L35-2	154-2190M1	271

CFG	
RF BOC	
B C D	

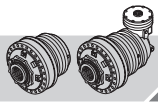

RR2500

IT EN DE FR ES PT

RF170-290



RF5/..

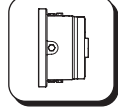

RFF5/..

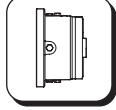

RF2/..

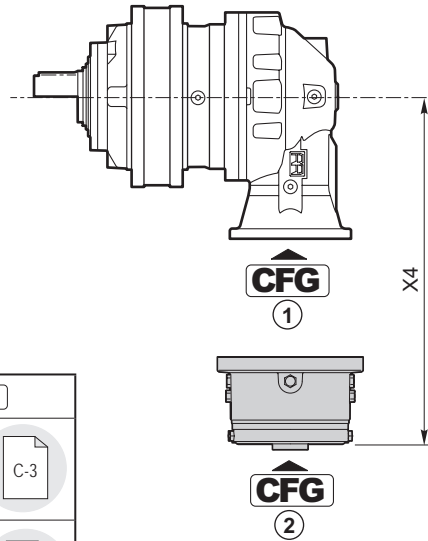
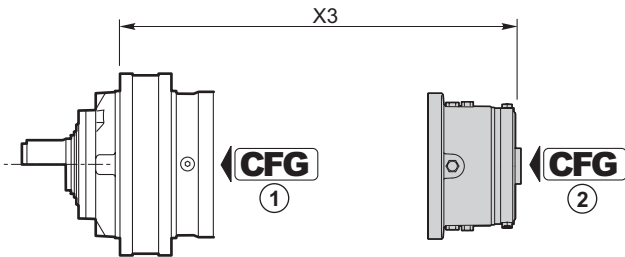
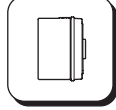

RF170-290	CFG ①	T _f [Nm]	CFG ②		
			C		
			code	X3	X4
RR2500 L2	RF	1700	154B9766M4	481	—
		2000	154B9767M4		
		2300	154B9768M4		
		2900	154B9769M4		
RR2500 A2(A)	—	1700	154B9766M3	—	485
		2000	154B9767M3		
		2300	154B9768M3		
		2900	154B9769M3		
RR2500 A2(B)	—	1700	154B9766M3	—	552
		2000	154B9767M3		
		2300	154B9768M3		
		2900	154B9769M3		

CFG	
RF	C-3
B C D	C-3

RF5/..	CFG ①	T _f [Nm]	CFG ②						
			B			OMTS 12/24 z16	OMVS 10/20 z16	X3	X4
			code	X3	X4	code	code	X3	X4
RR2500 L3	RF	210	154-2872	442.3	—	154-2879	154-2886	446	—
		290	154-2873			154-2880	154-2887		
		430	154-2874			154-2881	154-2888		
		650	154-2875			154-2882	154-2889		
		850	154-2876			154-2883	154-2890		
		1100	154-2877			154-2884	154-2891		
		1300	154-2878			154-2885	154-2892		



RFF5/..	CFG ①	T _f [Nm]	CFG ②						
			B			OMTS 12/24 z16	OMVS 10/20 z16		
			code	X3	X4	code	code	X3	X4
RR2500 A3	RF	210	154-2893	—	316.6	154-5338	154-5345	—	320.5
		290	154-2894			154-5339	154-5346		
		430	154-2895			154-5340	154-5347		
		650	154-2896			154-5341	154-5348		
		850	154-2897			154-5342	154-5349		
		1100	154-2898			154-5343	154-5350		
		1300	154-2899			154-5344	154-5351		

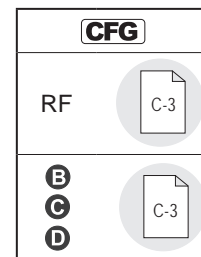

RF2/..	CFG ①	T _f [Nm]	CFG ②								
			B			OMP/OMR SAE A 2B Ø 25	OMP/OMR SAE A 2B 1" 6B	OMP/OMR SAE A 4B Ø 25	OMP/OMR SAE A 4B 1" 6B		
			code	X3	X4	code	code	code	code	X3	X4
RR2500 L3	RF	70	154-2345	414.8	—	154-2345M10	154-2345M11	154-2345M16	154-2345M17	404.8	—
		140	154-2346			154-2346M10	154-2346M11	154-2346M16	154-2346M17		
		210	154-2347			154-2347M10	154-2347M11	154-2347M16	154-2347M17		
		320	154-2348			154-2348M10	154-2348M11	154-2348M16	154-2348M17		
		430	154-2349			154-2349M10	154-2349M11	154-2349M16	154-2349M17		
		600	154B9186			154B9186M10	154B9186M11	154B9186M16	154B9186M17		
RR2500 L4	RF	70	154-2838M1	458.5	—	154-2863	154-2863M11	154-2635	154-2635M11	448.5	—
		140	154-2839M1			154-2864	154-2864M11	154-2636	154-2636M11		
		210	154-2840M1			154-2865	154-2865M11	154-2637	154-2637M11		
		320	154-2841M1			154-2866	154-2866M11	154-2638	154-2638M11		
		430	154-2842M1			154-2867	154-2867M11	154-2639	154-2639M11		
		600	154B8962M1			154B9665	154B9665M11	154B9666	154B9666M11		
RR2500 A3	RF	70	154F2991	—	285.3						
		140	154F1890								
		210	154F2961								
		320	154B3591								
		430	154B3592								
		600	154F2992								
RR2500 A4	RF	70	154-2838M12	—	223.8	154-2863M12	154-2863M13	154-2635M12		—	213.8
		140	154-2839M12			154-2864M12	154-2864M13	154-2636M12			
		210	154-2840M12			154-2865M12	154-2865M13	154-2637M12			
		320	154-2841M12			154-2866M12	154-2866M13	154-2638M12			
		430	154-2842M12			154-2867M12	154-2867M13	154-2639M12			
		600	154B8962M12			154B9665M12	154B9665M13	154B9666M12			

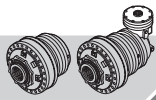

RR2500

IT EN DE FR ES PT

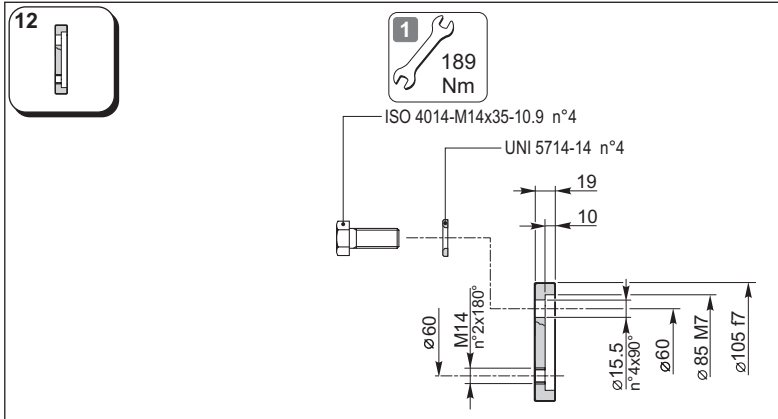

154F6030

Materiale / Material / Material / Matériau / Material / Material:
 Acciaio / Steel / Stahl / Acier / Acero / Aço
 EN 10083-1-42CrMo4+QT (1.7225)

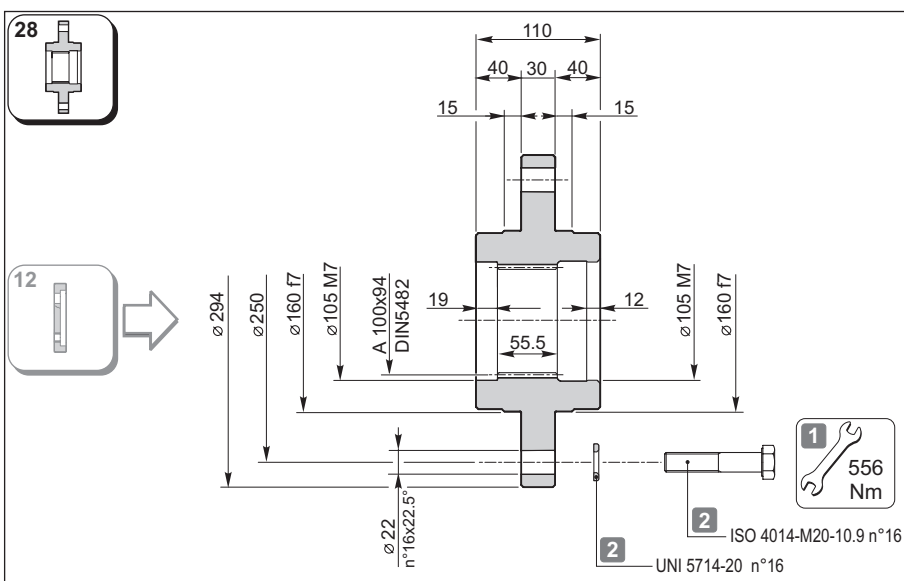

154F6047

Materiale / Material / Material
 Matériau / Material / Material
 Acciaio / Steel / Stahl / Acier / Acero / Aço
 EN 10083-1-C40 (1.1186)

Trattamento termico:
 Tempra ad induzione secondo UNI 10932 su scanalato interno

Heat treatment:
 Induction hardening according to UNI 10932 on internal spline

Wärmebehandlung:
 Induktionshärtung nach UNI 10932 an interner Nut

Traitement thermique:
 Trempe par induction conformément à la norme UNI 10932 sur cannelé interne

Tratamiento térmico:
 Temple por inducción según UNI 10932 en acanalado interno

Tratamento térmico:
 Tempra por indução segundo UNI 10932 sobre ranhuras internas

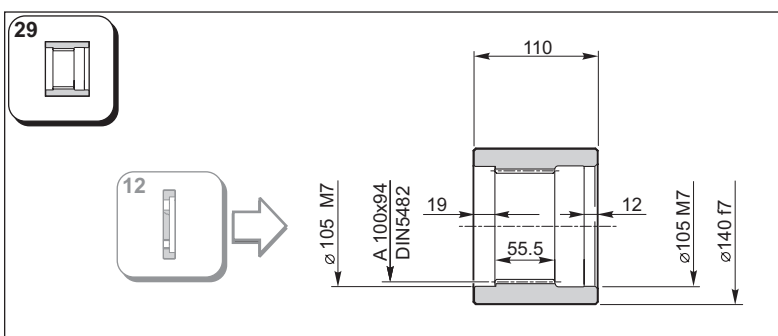

154F6055

Materiale / Materiale / Material / Matériau / Material / Material:
 Acciaio / Steel / Stahl / Acier / Acero / Aço
 EN 10083-1-42CrMo4+QT (1.7225)

Trattamento termico:
 Tempra ad induzione secondo UNI 10932 su scanalato interno

Heat treatment:
 Induction hardening according to UNI 10932 on internal spline

Wärmebehandlung:
 Induktionshärtung nach UNI 10932 an interner Nut

Traitement thermique:
 Trempe par induction conformément à la norme UNI 10932 sur cannelé interne

Tratamiento térmico:
 Temple por inducción según UNI 10932 en acanalado interno

Tratamento térmico:
 Tempra por indução segundo UNI 10932 sobre ranhuras internas

1 Coefficiente d'attrito medio considerato: 0.14
 Average friction coefficient considered: 0.14
 Durchschnittlicher berücksichtigter Reibungskoeffizient: 0.14
 Coefficient de frottement moyen considéré: 0.14
 Coeficiente medio de fricción considerado: 0.14
 Coeficiente de atrito médio considerado: 0.14

2 Componenti non forniti da Reggiana Riduttori
 Components not supplied by Reggiana Riduttori
 Nicht von Reggiana Riduttori gelieferte Komponenten
 Parties pas fournies par Reggiana Riduttori
 Componentes no suministrados por Reggiana Riduttori
 Componentes não fornecidos por Reggiana Riduttori

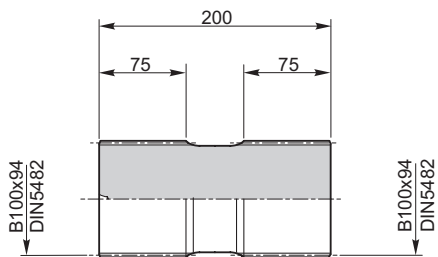
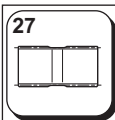
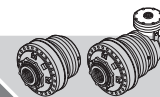

Materiale / Material / Material / Matériau / Material / Material:
 Acciaio / Steel / Stahl / Acier / Acero / Aço
 EN 10083-1-42CrMo4+QT (1.7225)

154F6036

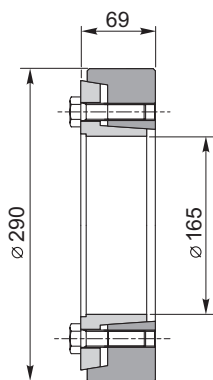
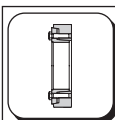

154F6065

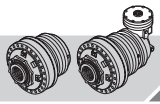

RR2500

IT EN DE FR ES PT

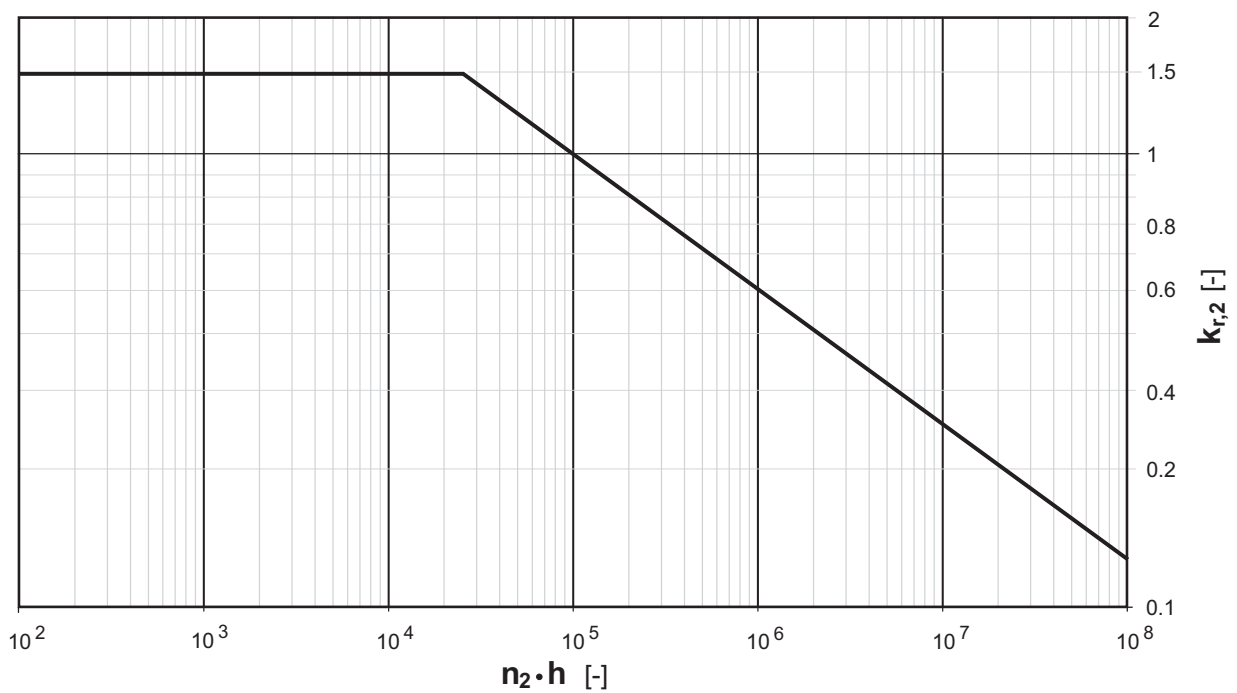
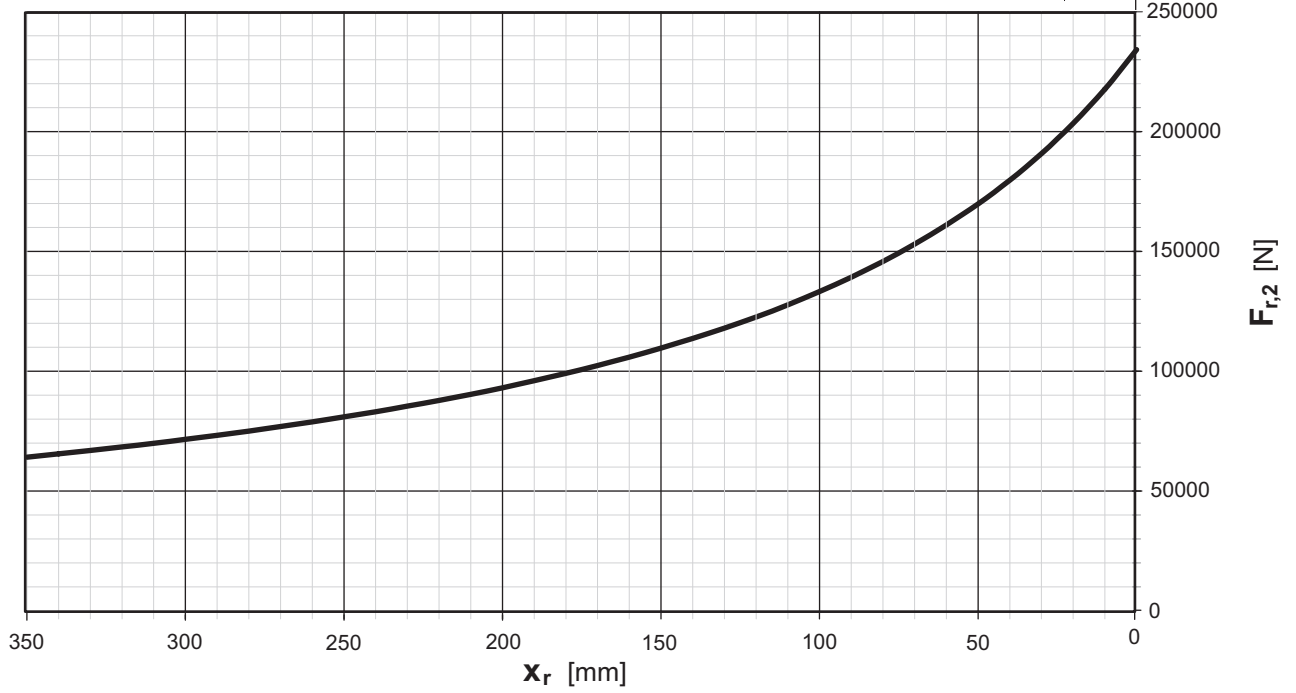
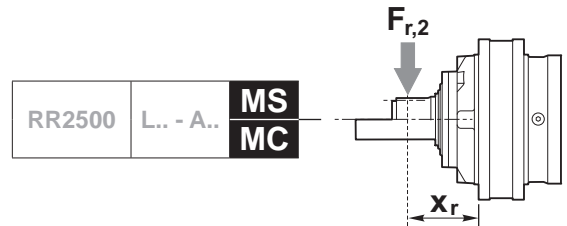

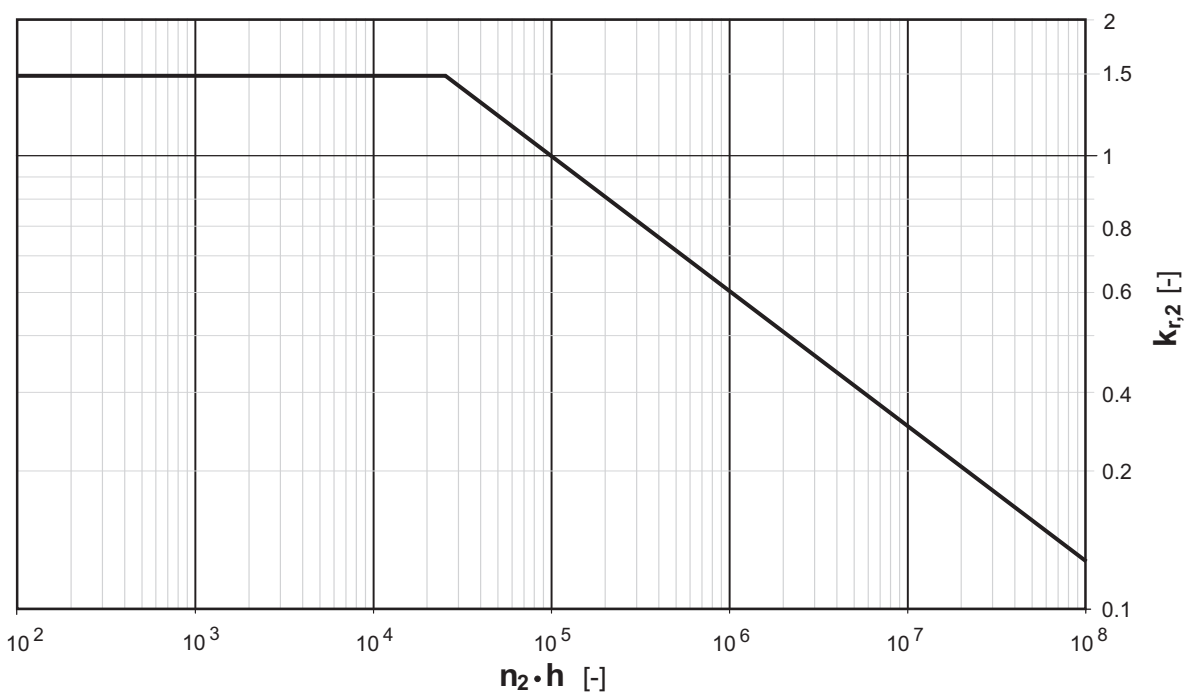
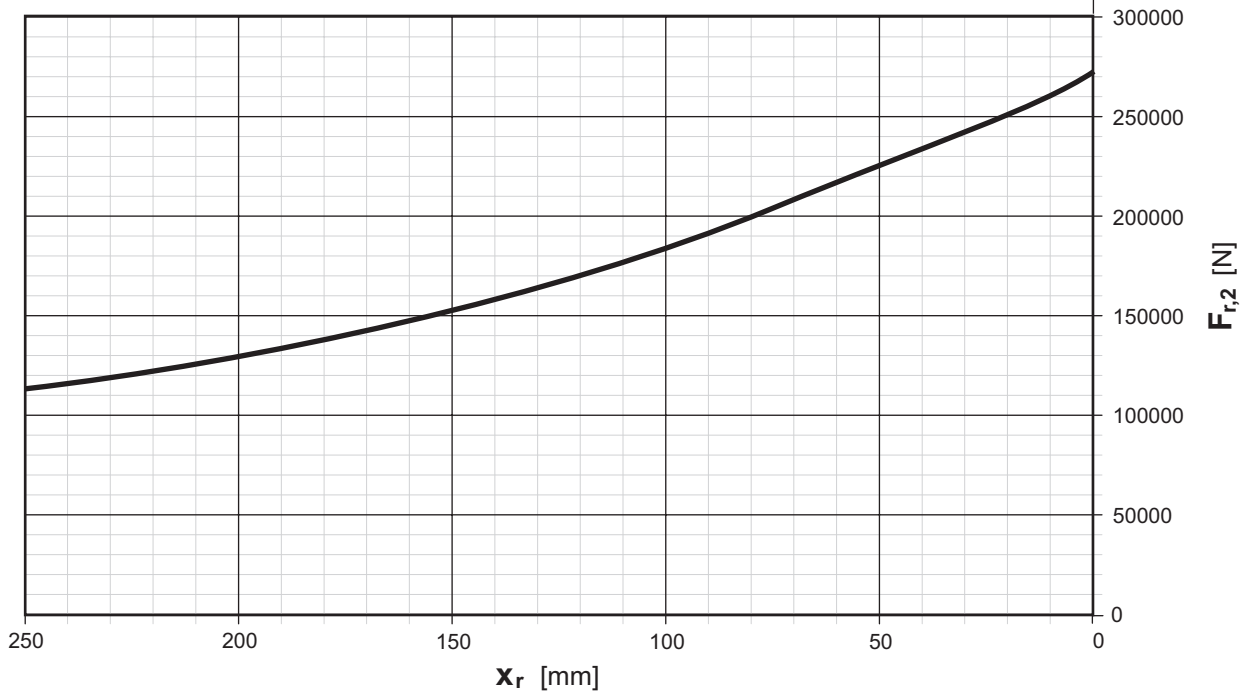
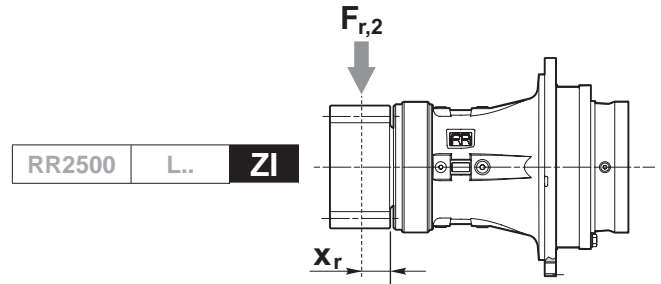



RR3200

IT EN DE FR ES PT

RR3200 L.. .. **i**



i	T ₂ [Nm]						n _{1max} [min ⁻¹]	T _{2max} [Nm]	P _t [kW]	
	n ₂ x h									
1/...	10000 (10 ⁴)	25000 (2.5 · 10 ⁴)	50000 (5 · 10 ⁴)	100000 (10 ⁵)	500000 (5 · 10 ⁵)	1000000 (10 ⁶)				
RR3200 L1	4.00	40450	36900	32180	29480	24180	19640	1500	58000	46
	4.71	34020	28370	24720	23310	21120	19220	1500	58000	46
	5.85	24690	20570	18290	17530	15880	15220	1500	58000	46
RR3200 L2	16.00	40450	36900	32180	29480	24180	19640	2500	58000	27
	20.00	40450	36900	32180	29480	24180	19640	2500	58000	27
	23.20	32530	29200	27980	26810	24180	19640	2500	58000	27
	27.29	34020	28370	24720	23310	21120	19220	2500	58000	27
	32.94	27530	26030	24720	23310	21120	19220	2500	58000	27
	40.92	24690	20570	18290	17530	15880	15220	2500	58000	27
RR3200 L3	54.40	40450	36900	32180	29480	24180	19640	3500	58000	20
	64.00	40450	36900	32180	29480	24180	19640	3500	58000	20
	68.00	40450	36900	32180	29480	24180	19640	3500	58000	20
	80.00	40450	36900	32180	29480	24180	19640	3500	58000	20
	92.80	39990	36900	32180	29480	24180	19640	3500	58000	20
	100.00	40450	36900	32180	29480	24180	19640	3500	58000	20
	116.00	40450	36900	32180	29480	24180	19640	3500	58000	20
	140.00	35120	33200	31820	29480	24180	19640	3500	58000	20
	162.40	32530	29200	27980	26810	24180	19640	3500	58000	20
	191.06	34020	28370	24720	23310	21120	19220	3500	58000	20
	230.59	27530	26030	24720	23310	21120	19220	3500	58000	20
	286.46	24690	20570	18290	17530	15880	15220	3500	58000	20
RR3200 L4	217.60	40450	36900	32180	29480	24180	19640	3500	58000	16
	256.00	40450	36900	32180	29480	24180	19640	3500	58000	16
	315.52	40450	36900	32180	29480	24180	19640	3500	58000	16
	400.00	40450	36900	32180	29480	24180	19640	3500	58000	16
	448.00	40450	36900	32180	29480	24180	19640	3500	58000	16
	500.00	40450	36900	32180	29480	24180	19640	3500	58000	16
	560.00	40450	36900	32180	29480	24180	19640	3500	58000	16
	649.60	39990	36900	32180	29480	24180	19640	3500	58000	16
	700.00	40450	36900	32180	29480	24180	19640	3500	58000	16
	812.00	40450	36900	32180	29480	24180	19640	3500	58000	16
	980.00	35120	33200	31820	29480	24180	19640	3500	58000	16
	1136.80	32530	29200	27980	26810	24180	19640	3500	58000	16
	1337.41	34020	28370	24720	23310	21120	19220	3500	58000	16
	1614.12	27530	26030	24720	23310	21120	19220	3500	58000	16
	2005.23	24690	20570	18290	17530	15880	15220	3500	58000	16

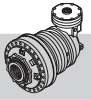

RR3200 A.. .. **i**



i 1/...	T ₂ [Nm]						n _{1max} [min ⁻¹]	T _{2max} [Nm]	P _t [kW]
	n ₂ x h								
	10000 (10 ⁴)	25000 (2.5 · 10 ⁴)	50000 (5 · 10 ⁴)	100000 (10 ⁵)	500000 (5 · 10 ⁵)	1000000 (10 ⁶)			

RR3200 A2 (A)	10.91	24420	24420	20490	16640	10270	8340	2500	58000	36
		12.83	28730	28270	22960	18650	11510	9350	2500	58000
	15.94	24690	20570	18290	17530	13390	10880	2500	58000	36
	19.29	24690	20570	18290	17530	12900	10470	2500	58000	36
	22.74	24690	20570	18290	17530	12170	9890	2500	58000	36
(B)	11.08	28090	27130	24330	19760	12200	9910	2500	58000	40
	13.03	32220	28370	24720	22150	13660	11100	2500	58000	40
	14.90	29000	28370	24720	22420	13840	11240	2500	58000	40
	19.25	25100	21400	19320	18510	13750	11170	2500	58000	40
	23.92	24690	20570	18290	17530	15880	13000	2500	58000	40
(C)	9.85	40450	36900	32180	29480	24180	19640	2000	58000	53
	12.67	40450	36900	32180	29480	24180	19640	2000	58000	53
	15.27	40450	36900	32180	29480	24180	19640	2000	58000	53
	17.97	34020	28370	24720	23310	21120	19220	2000	58000	53
	22.32	24690	20570	18290	17530	15880	15220	2000	58000	53

RR3200 A3 (A)	43.08	33340	26580	21590	17540	10820	8790	3500	58000	22
	53.85	40450	31070	25240	20500	12650	10280	3500	58000	22
	62.46	32530	29200	27980	22750	14030	11400	3500	58000	22
	73.48	34020	28370	24720	23310	15730	12770	3500	58000	22
	88.69	27530	26030	24720	23310	17940	14570	3500	58000	22
	103.89	27530	26030	24720	23310	17670	14350	3500	58000	22
	131.76	27530	26030	24720	23310	16930	13750	3500	58000	22
	163.69	24690	20570	18290	17530	15880	15220	3500	58000	22
(B)	43.64	40450	36900	32180	29480	24180	19640	2500	58000	27
	54.55	40450	36900	32180	29480	24180	19640	2500	58000	27
	66.00	40450	36900	32180	29480	24180	19640	2500	58000	27
	77.78	40450	36900	32180	29480	24180	19640	2500	58000	27
	90.22	32530	29200	27980	26810	24180	19640	2500	58000	27
	106.14	34020	28370	24720	23310	21120	19220	2500	58000	27
	128.10	27530	26030	24720	23310	21120	19220	2500	58000	27
	159.15	24690	20570	18290	17530	15880	15220	2500	58000	27

RR3200 A4	146.46	40450	36900	32180	29480	24180	19640	3500	58000	19
	172.31	40450	36900	32180	29480	24180	19640	3500	58000	19
	201.85	40450	36900	32180	29480	24180	19640	3500	58000	19
	215.38	40450	36900	32180	29480	24180	19640	3500	58000	19
	256.00	40450	36900	32180	29480	24180	19640	3500	58000	19
	272.00	40450	36900	32180	29480	24180	19640	3500	58000	19
	292.68	39990	36900	32180	29480	24180	19640	3500	58000	19
	320.00	40450	36900	32180	29480	24180	19640	3500	58000	19
	371.20	39990	36900	32180	29480	24180	19640	3500	58000	19
	400.00	40450	36900	32180	29480	24180	19640	3500	58000	19
	464.00	40450	36900	32180	29480	24180	19640	3500	58000	19
	512.18	32530	29200	27980	26810	24180	19640	3500	58000	19
	560.00	35120	33200	31820	29480	24180	19640	3500	58000	19
	649.60	32530	29200	27980	26810	24180	19640	3500	58000	19
	764.24	34020	28370	24720	23310	21120	19220	3500	58000	19
	922.35	27530	26030	24720	23310	21120	19220	3500	58000	19
	1145.85	24690	20570	18290	17530	15880	15220	3500	58000	19



RR3200

IT EN DE FR ES PT

RR3200 L.. .. i



L1

MS MC FS MH 195 RR3200 L1

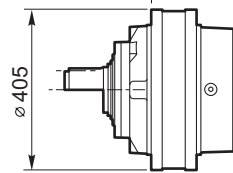

L2

MS MC FS MH 297 RR3200 L2

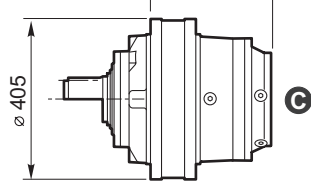

ZI 297 RR3200 L2

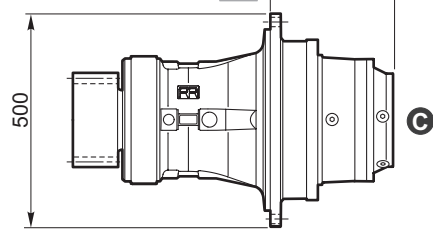

L3

MS MC FS MH 373 RR3200 L3

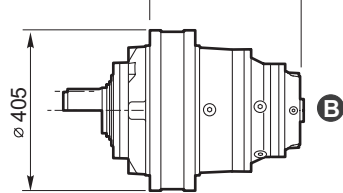

ZI 373 RR3200 L3

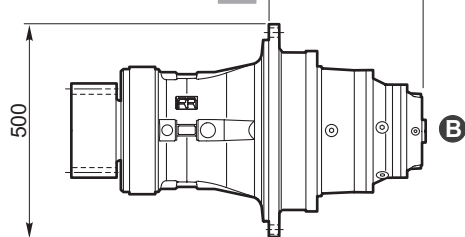

L4

MS MC FS MH 439.5 RR3200 L4

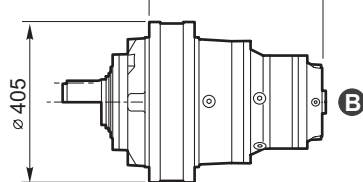

ZI 439.5 RR3200 L4

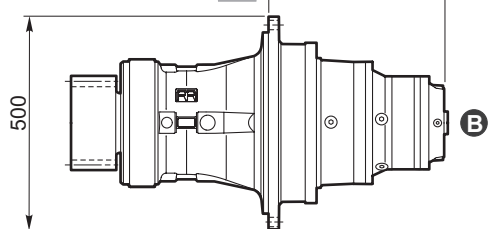

CFG

RF BOC	
B C D	

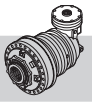

RR3200 A.. .. i

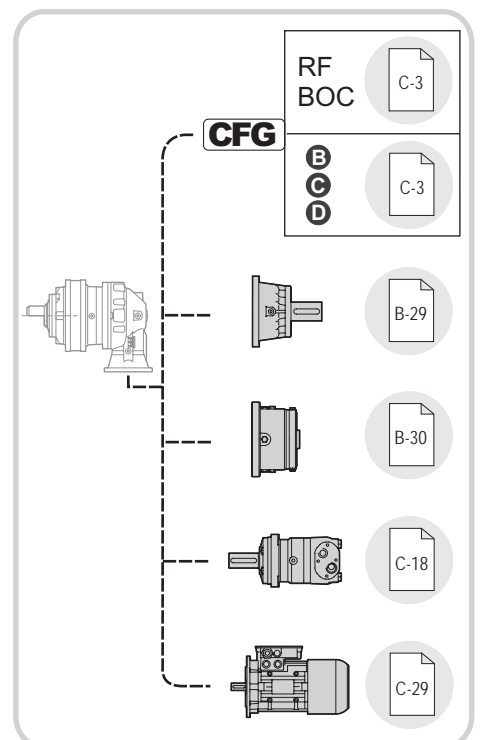
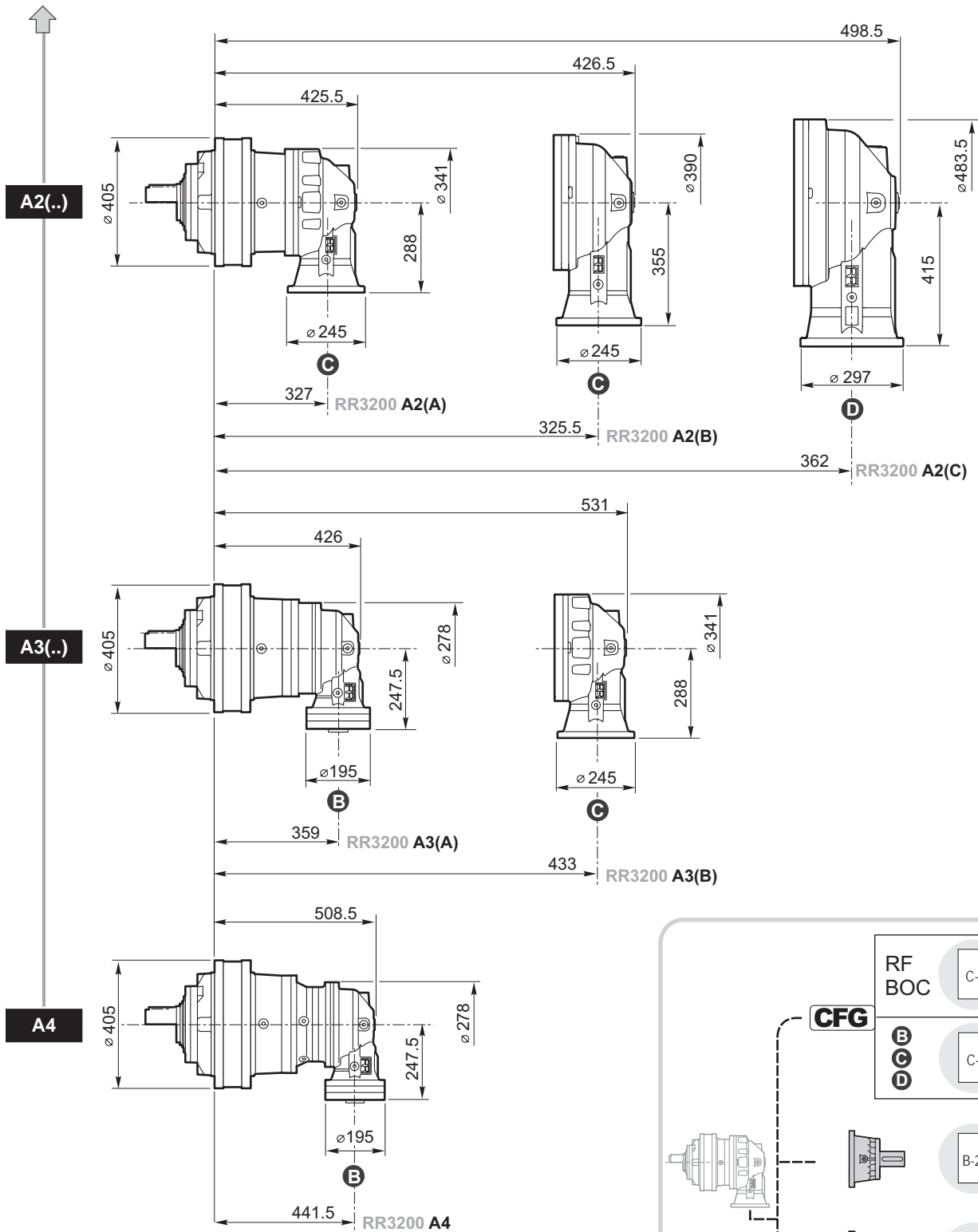

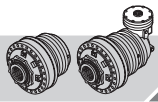

RR3200

IT EN DE FR ES PT

RR3200	L..	MS	i
RR3200	A..		i

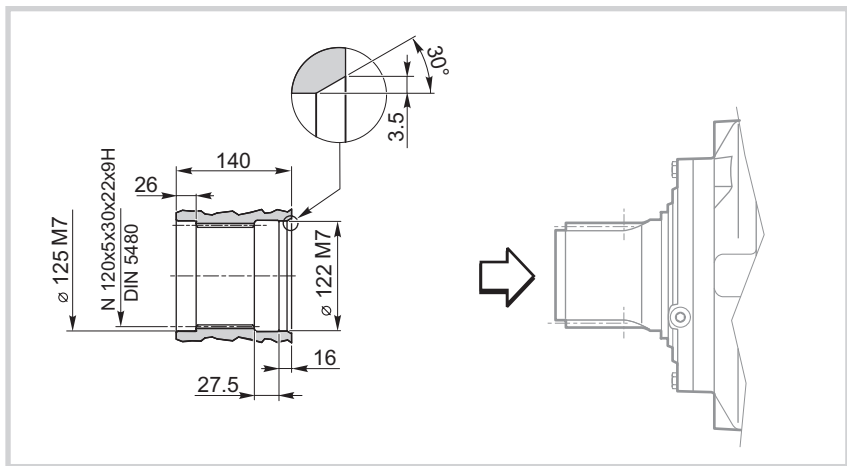
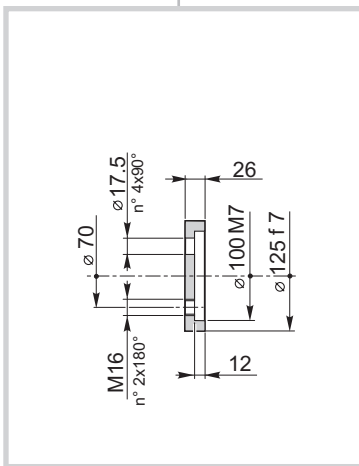
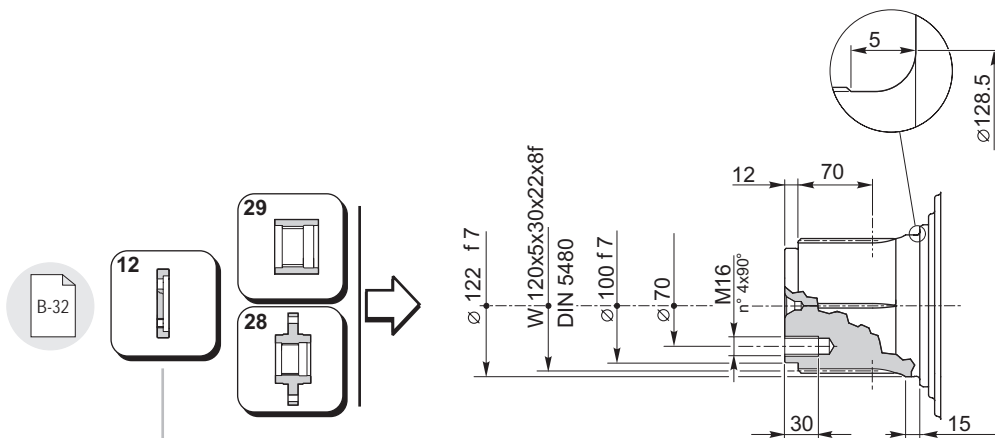
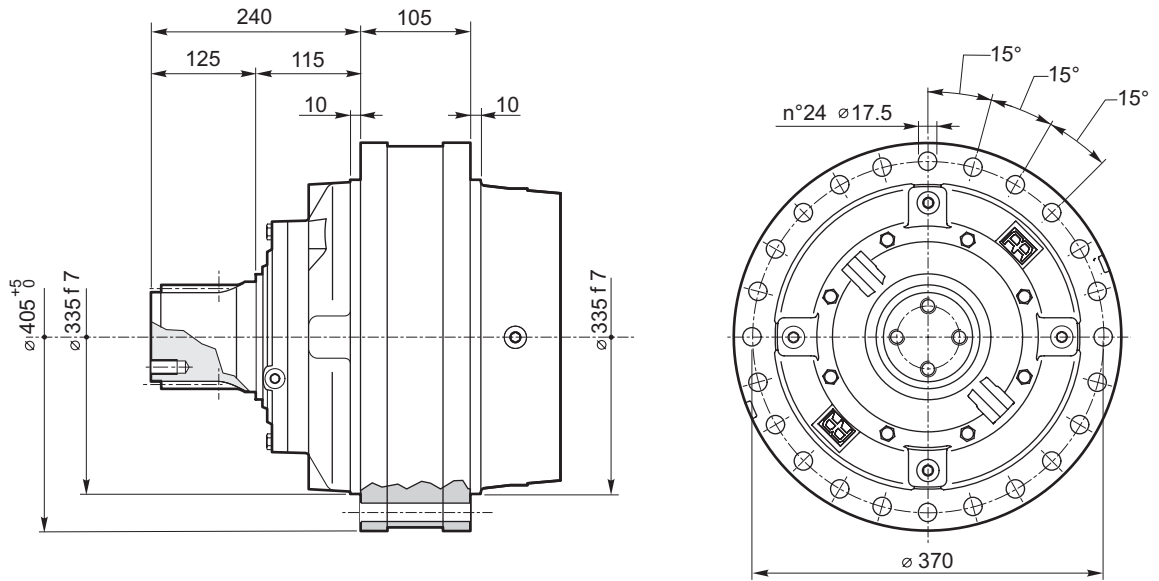

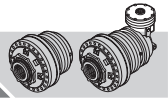

RR3200	L..	MC	i
RR3200	A..		i

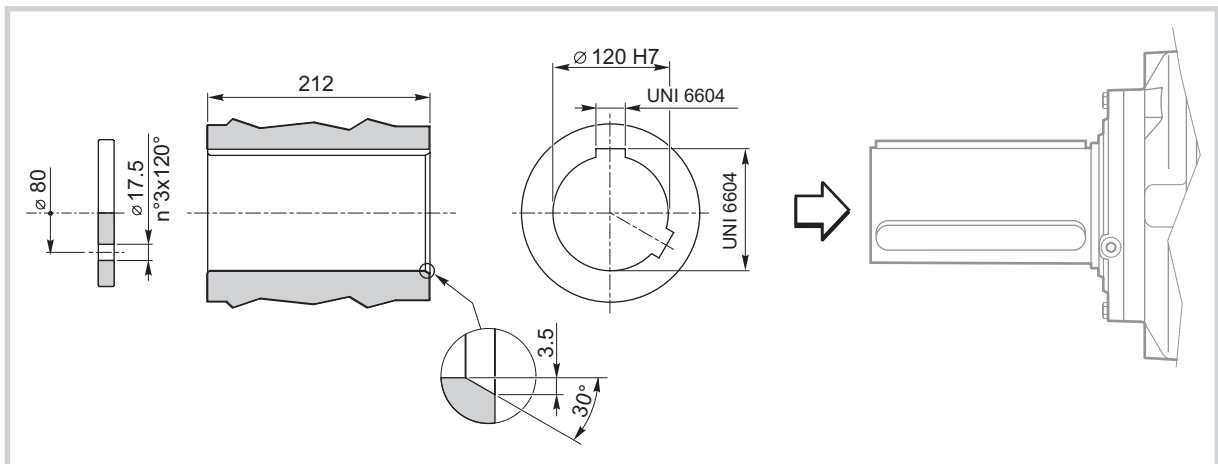
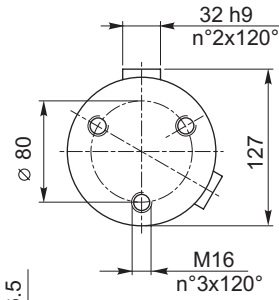
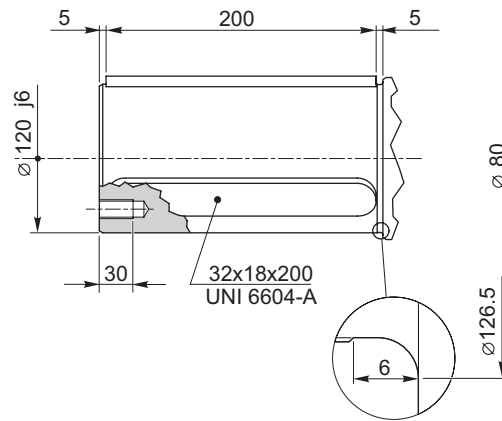
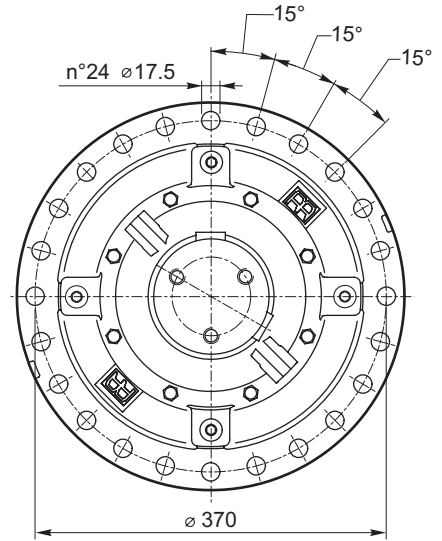
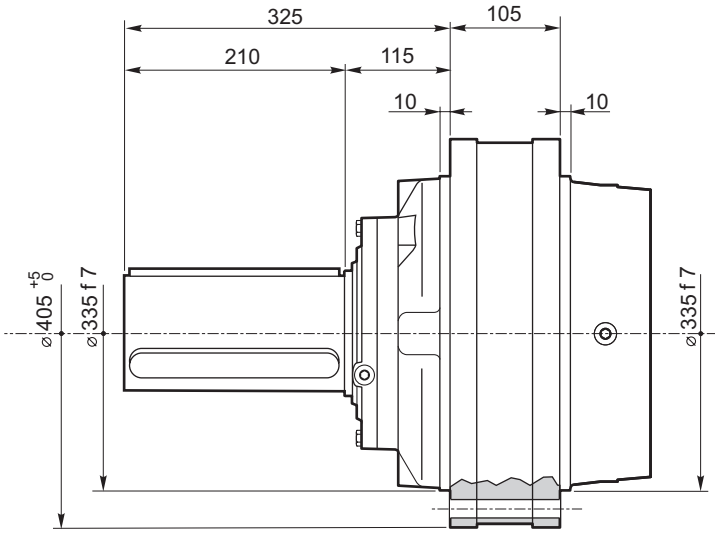

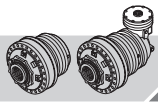

RR3200

IT EN DEFRES PT

RR3200	L..	FS	i
RR3200	A..		i

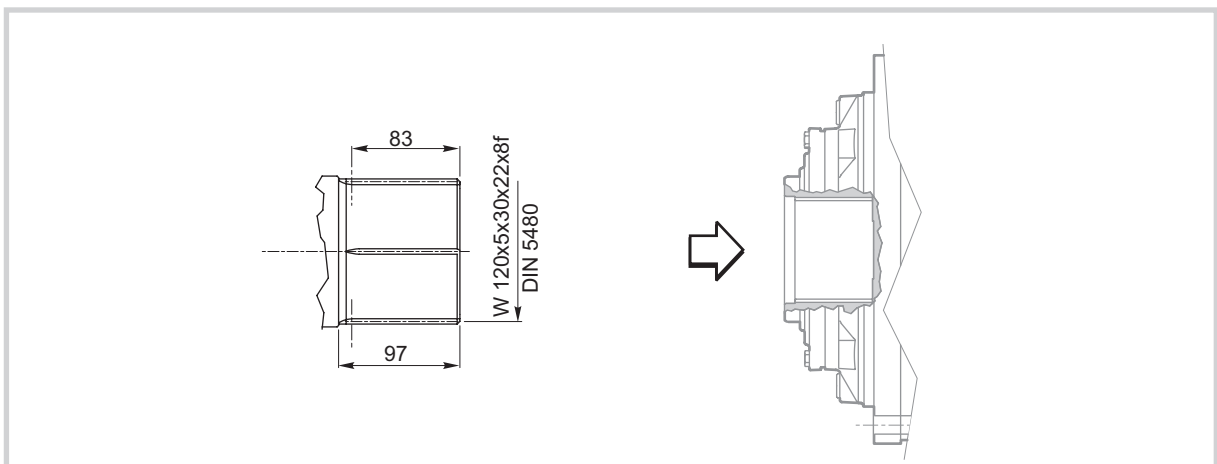
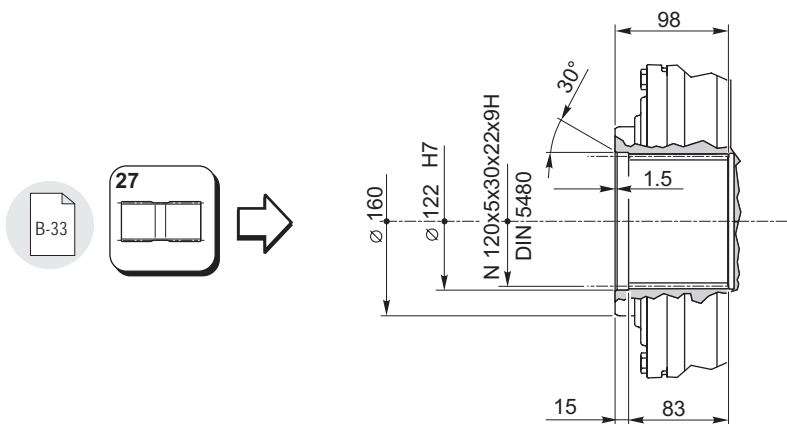
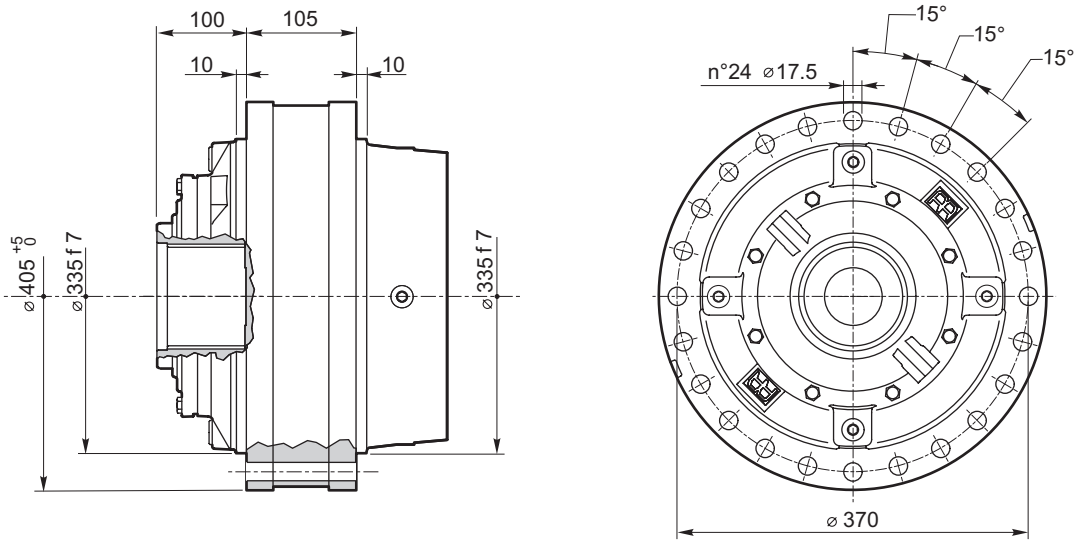

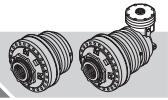

RR3200	L..	MH	i
RR3200	A..		i

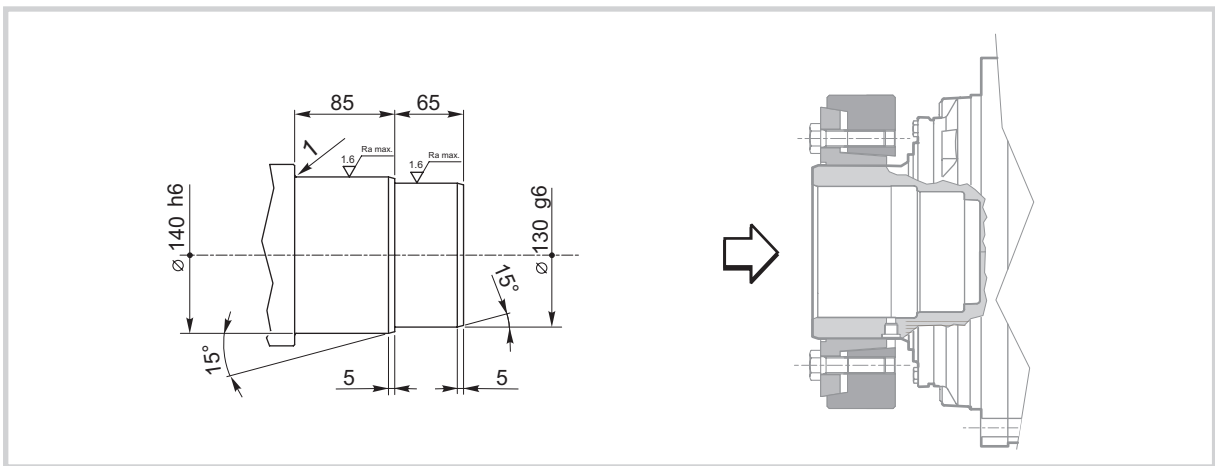
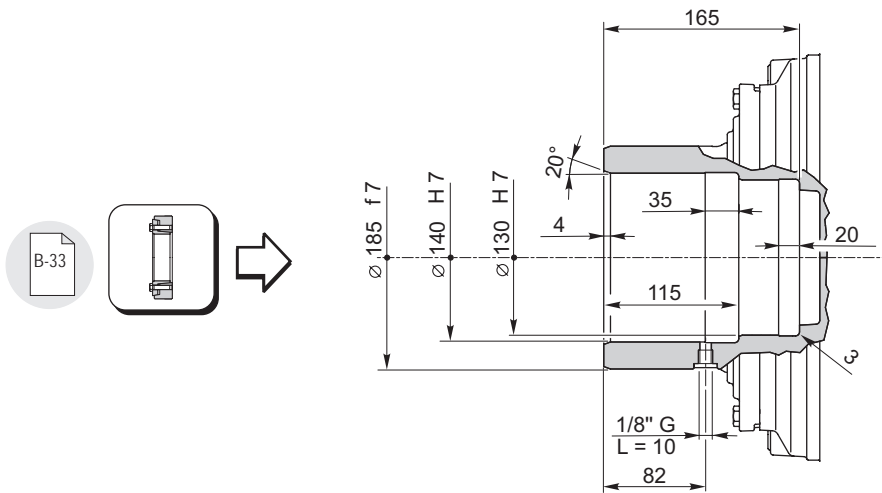
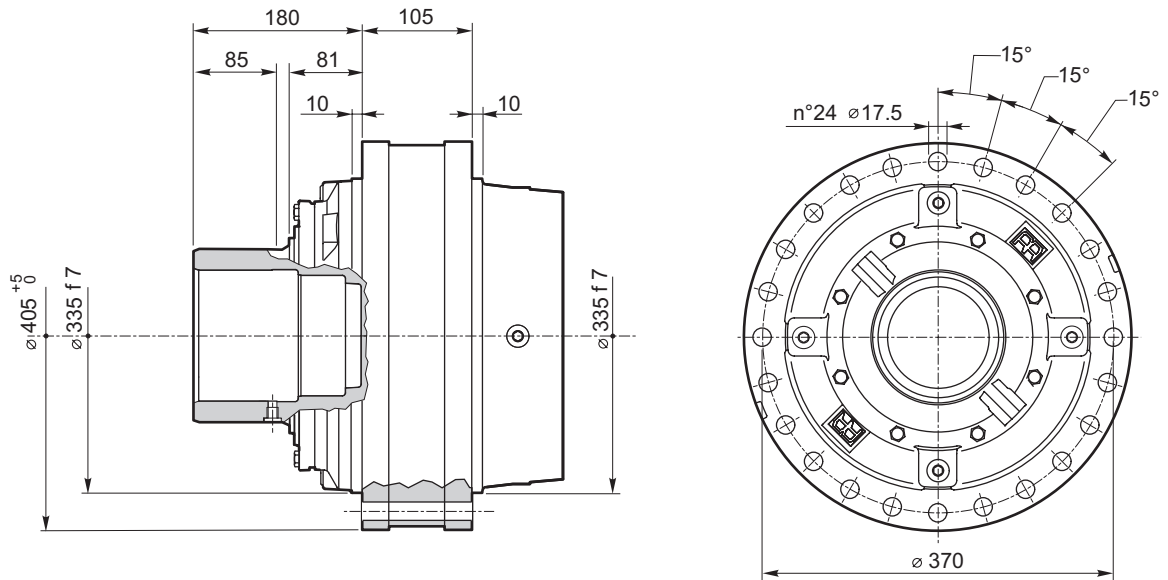



RR3200

IT EN DE FR ES PT

RR3200 L.. ZI i

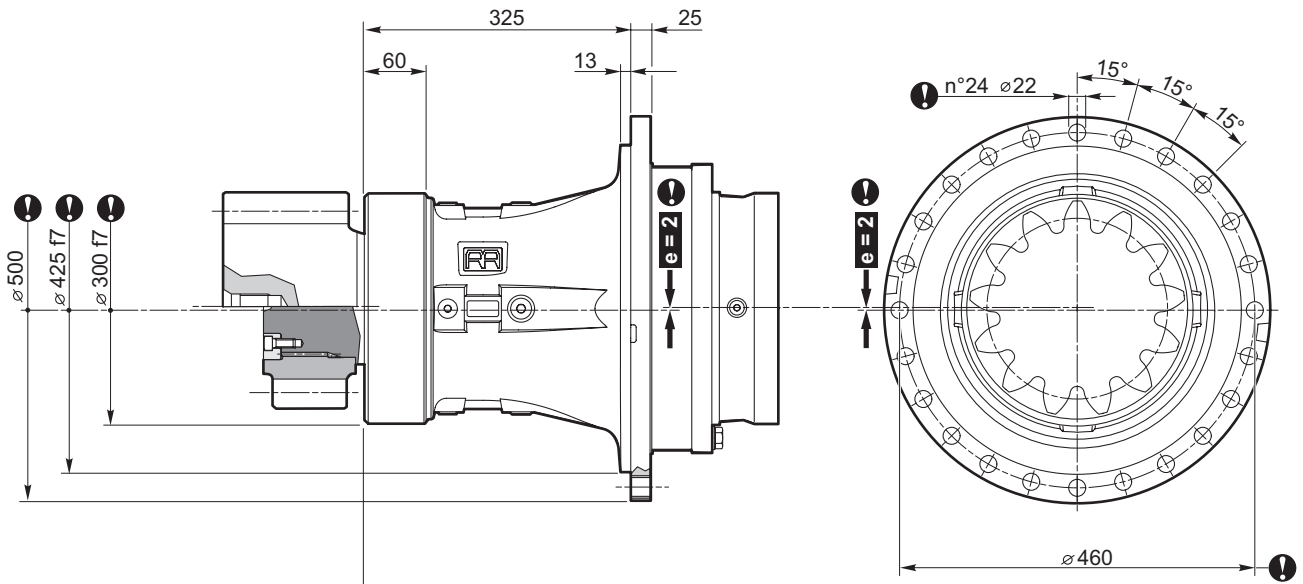

❗ Quote riferite all'asse con eccentricità "e"
 Dimensions that refer to the axis with "e" eccentricity
 Quoten beziehen sich auf die Achse mit Ausmittigkeit "e"
 Cotes se rapportant à l'axe avec excentricité "e"
 Quotas referidas ao eixo com excentricidade "e"
 Cotas referidas al eje con excentricidad "e"

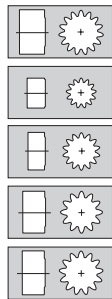
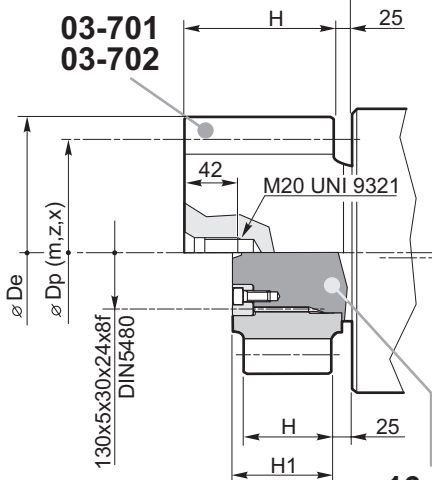

m	z	x	H	H1	Dp	De	code
16	15	0.3125	160	—	240	282	03-701
12	13	0.5	110	—	156	190	03-702
14	14	0.5	105	114.5	196	238	16-245
18	12	0.5	140	140	216	265	16-247
18	13	0.4	140	140	234	279	16-248

16-245
 16-247
 16-248

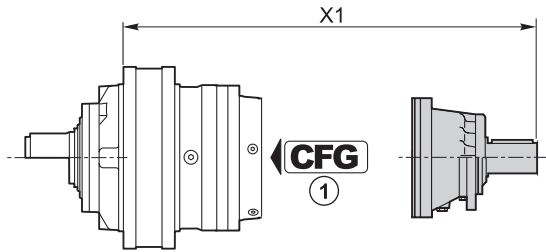
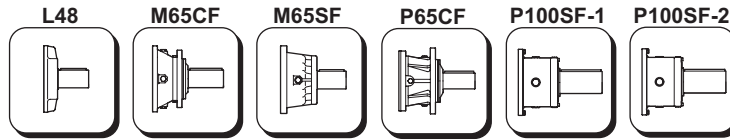
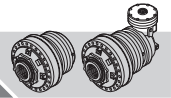

	CFG ①		code	X1
RR3200 L1	—	P100SF-2	154F5948	569.5
RR3200 L2	—	P65CF	154-2404	609
RR3200 L3	RF	M65SF	154B4249	557.5
	RF	M65CF	154-2407	580.5
	BOC	L48	154B3989	494.3
RR3200 L4	RF	M65SF	154B4249	624
	RF	M65CF	154-2407	647
	BOC	L48	154B3989	560.8

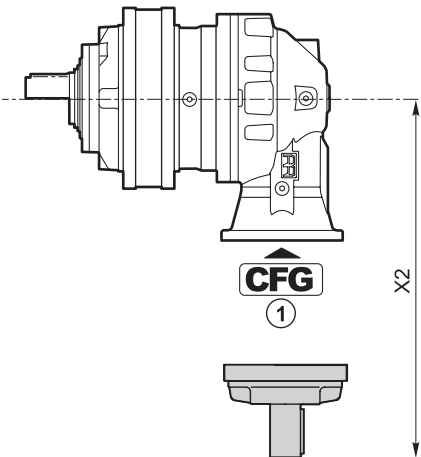

	CFG ①		code	X2
RR3200 A2(A)	—	P65CF	154-2404	600
RR3200 A2(B)	—	P65CF	154-2404	667
RR3200 A2(C)	—	P100SF-1	154F3322	791.5
RR3200 A3(A)	BOC	L48	154B3989	347.8
RR3200 A3(B)	—	P65CF	154-2404	600
RR3200 A4	BOC	L48	154B3989	347.8

CFG	
RF BOC	
B C D	

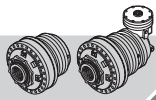

RR3200

IT EN DE FR ES PT

RF170-290

RF5/..

RFF5/..

RF2/..

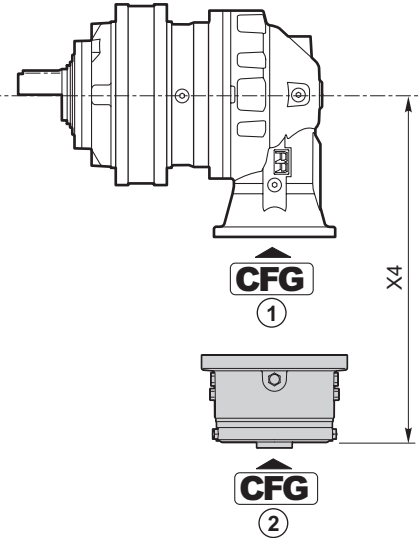
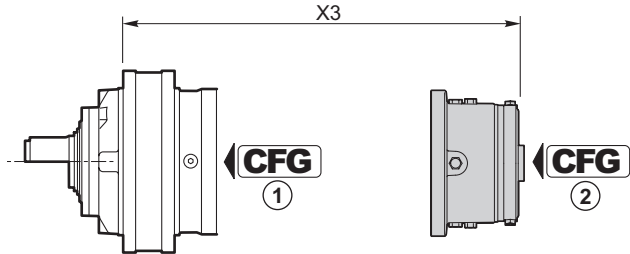
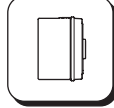
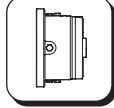
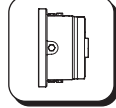

RF170-290	CFG ①	T _f [Nm]	CFG ②		
			C		
			code	X3	X4
RR3200 L2	RF	1700	154B9766M1	494	—
		2000	154B9767M1		
		2300	154B9768M1		
		2900	154B9769M1		
RR3200 A2(A)	—	1700	154B9766M3	—	485
		2000	154B9767M3		
		2300	154B9768M3		
RR3200 A2(B)	—	1700	154B9766M3	—	552
		2000	154B9767M3		
		2300	154B9768M3		
RR3200 A3(B)	—	1700	154B9766M3	—	485
		2000	154B9767M3		
		2300	154B9768M3		
		2900	154B9769M3		

CFG	
RF BOC	C-3
B	C-3
C	
D	

RF5/..	CFG ①	T _f [Nm]	CFG ②						
			B			OMTS	OMVS	X3	X4
			code	X3	X4	12/24 z16	10/20 z16		
			code			code	code		
RR3200 L3	RF	210	154-2872	465.3	—	154-2879	154-2886	467	—
		290	154-2873			154-2880	154-2887		
		430	154-2874			154-2881	154-2888		
		650	154-2875			154-2882	154-2889		
		850	154-2876			154-2883	154-2890		
		1100	154-2877			154-2884	154-2891		
RR3200 L4	RF	1300	154-2878	531.8	—	154-2885	154-2892	533.5	—
		210	154-2872			154-2879	154-2886		
		290	154-2873			154-2880	154-2887		
		430	154-2874			154-2881	154-2888		
		650	154-2875			154-2882	154-2889		
		850	154-2876			154-2883	154-2890		
1100	154-2877	154-2884	154-2891						
1300	154-2878	154-2885	154-2892						

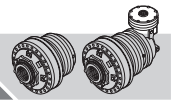

RFF5/..	CFG ①	T _f [Nm]	CFG ②						
			B			OMTS 12/24 z16	OMVS 10/20 z16	X3	X4
			code	X3	X4	code	code		
RR3200 A3(A)	RF	210	154-2893	—	316.6	154-5338	154-5345	—	320.5
		290	154-2894			154-5339	154-5346		
		430	154-2895			154-5340	154-5347		
		650	154-2896			154-5341	154-5348		
		850	154-2897			154-5342	154-5349		
		1100	154-2898			154-5343	154-5350		
		1300	154-2899			154-5344	154-5351		
RR3200 A4	RF	210	154-2893	—	316.6	154-5338	154-5345	—	320.5
		290	154-2894			154-5339	154-5346		
		430	154-2895			154-5340	154-5347		
		650	154-2896			154-5341	154-5348		
		850	154-2897			154-5342	154-5349		
		1100	154-2898			154-5343	154-5350		
		1300	154-2899			154-5344	154-5351		

CFG	
RF	
B C D	

RF2/..	CFG ①	T _f [Nm]	CFG ②								
			B			OMP/OMR SAE A 2B Ø 25	OMP/OMR SAE A 2B 1" 6B	OMP/OMR SAE A 4B Ø 25	OMP/OMR SAE A 4B 1" 6B	X3	X4
			code	X3	X4	code	code	code	code		
RR3200 L3	RF	70	154B9195	435.8	—	154B9195M10	—	154B9195M16	154B9195M17	425.8	—
		140	154B9196			154B9196M10	—	154B9196M16	154B9196M17		
		210	154B9197			154B9197M10	—	154B9197M16	154B9197M17		
		320	154B9198			154B9198M10	—	154B9198M16	154B9198M17		
		430	154B9199			154B9199M10	—	154B9199M16	154B9199M17		
		600	154B9200			154B9200M10	—	154B9200M16	154B9200M17		
		RR3200 L4	RF			70	154-2345	502.3	—		
140	154-2346			154-2346M10	154-2346M11	154-2346M16	154-2346M17				
210	154-2347			154-2347M10	154-2347M11	154-2347M16	154-2347M17				
320	154-2348			154-2348M10	154-2348M11	154-2348M16	154-2348M17				
430	154-2349			154-2349M10	154-2349M11	154-2349M16	154-2349M17				
600	154B9186			154B9186M10	154B9186M11	154B9186M16	154B9186M17				
RR3200 A3(A)	RF			70	154F2991	—	285.3				
		140	154F1890								
		210	154F2961								
		320	154B3591								
		430	154B3592								
		600	154F2992								
RR3200 A4	RF	70	154F2991	—	285.3						
		140	154F1890								
		210	154F2961								
		320	154B3591								
		430	154B3592								
		600	154F2992								

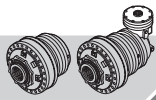

RR3200

IT EN DE FR ES PT

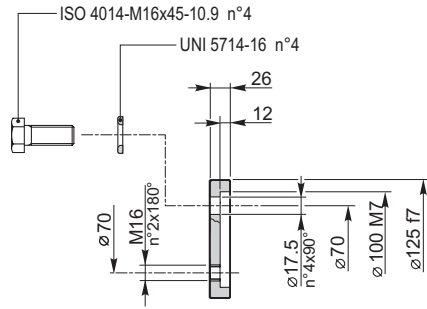
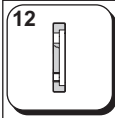

154F6031

Materiale / Material / Material / Matériau / Material / Material:
 Acciaio / Steel / Stahl / Acier / Acero / Aço
 EN 10083-1-42CrMo4+QT (1.7225)

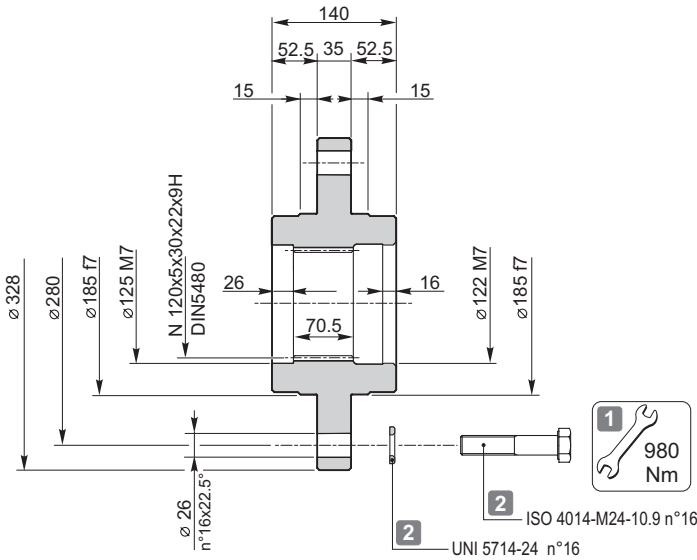
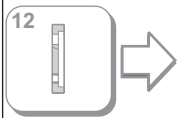
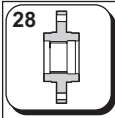

154F6048

Materiale / Material / Material / Matériau / Material / Material:
 Acciaio / Steel / Stahl / Acier / Acero / Aço
 EN 10083-1-C40 (1.1186)

Trattamento termico:
 Tempra ad induzione secondo UNI 10932 su scanalato interno

Heat treatment:
 Induction hardening according to UNI 10932 on internal spline

Wärmebehandlung:
 Induktionshärtung nach UNI 10932 an interner Nut

Traitement thermique :
 Trempe par induction conformément à la norme UNI 10932 sur cannelé interne

Tratamiento térmico:
 Temple por inducción según UNI 10932 en acanalado interno

Tratamento térmico:
 Tempra por indução segundo UNI 10932 sobre ranhuras internas

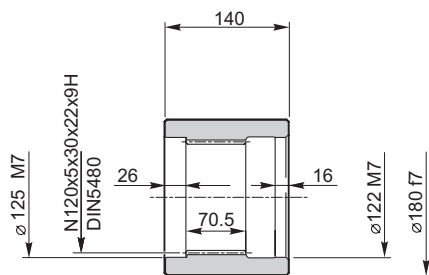
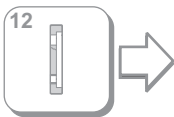

154F6056

Materiale / Material / Material / Matériau / Material / Material:
 Acciaio / Steel / Stahl / Acier / Acero / Aço
 EN 10083-1-42CrMo4+QT (1.7225)

Trattamento termico:
 Tempra ad induzione secondo UNI 10932 su scanalato interno

Heat treatment:
 Induction hardening according to UNI 10932 on internal spline

Wärmebehandlung:
 Induktionshärtung nach UNI 10932 an interner Nut

Traitement thermique :
 Trempe par induction conformément à la norme UNI 10932 sur cannelé interne

Tratamiento térmico:
 Temple por inducción según UNI 10932 en acanalado interno

Tratamento térmico:
 Tempra por indução segundo UNI 10932 sobre ranhuras internas

1 Coefficiente d'attrito medio considerato: 0.14
 Average friction coefficient considered: 0.14
 Durchschnittlicher berücksichtigter Reibungskoeffizient: 0.14
 Coefficient de frottement moyen considéré: 0.14
 Coeficiente medio de fricción considerado: 0.14
 Coeficiente de atrito médio considerado: 0.14

2 Componenti non forniti da Reggiana Riduttori
 Components not supplied by Reggiana Riduttori
 Nicht von Reggiana Riduttori gelieferte Komponenten
 Parties pas fournies par Reggiana Riduttori
 Componentes no suministrados por Reggiana Riduttori
 Componentes não fornecidos por Reggiana Riduttori

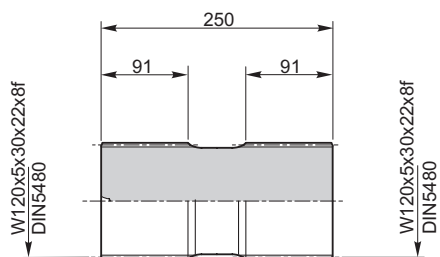
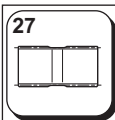
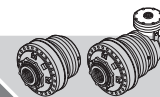

Materiale / Material / Material / Matériau / Material / Material:
 Acciaio / Steel / Stahl / Acier / Acero / Aço
 EN 10083-1-42CrMo4+QT (1.7225)

154F6037

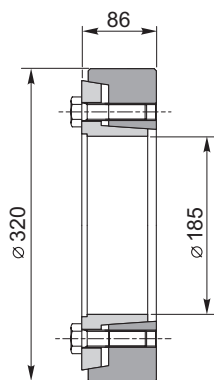
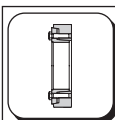

154F6066

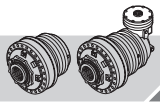

RR3200

IT EN DE FR ES PT

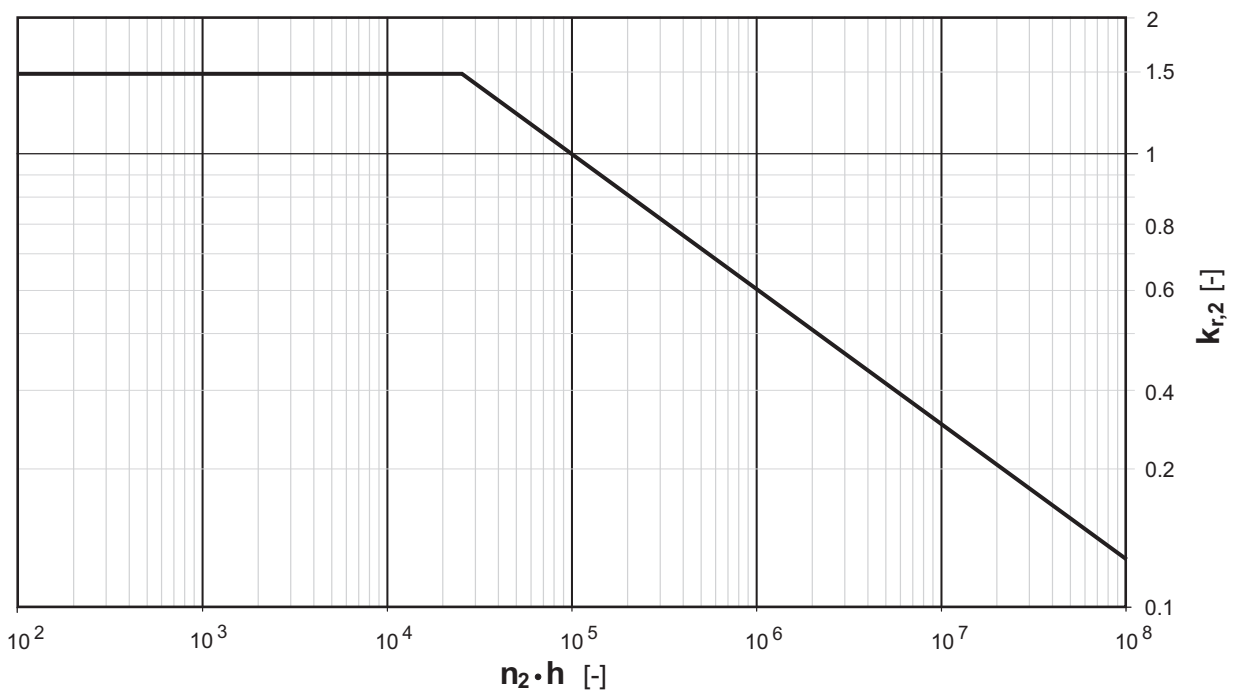
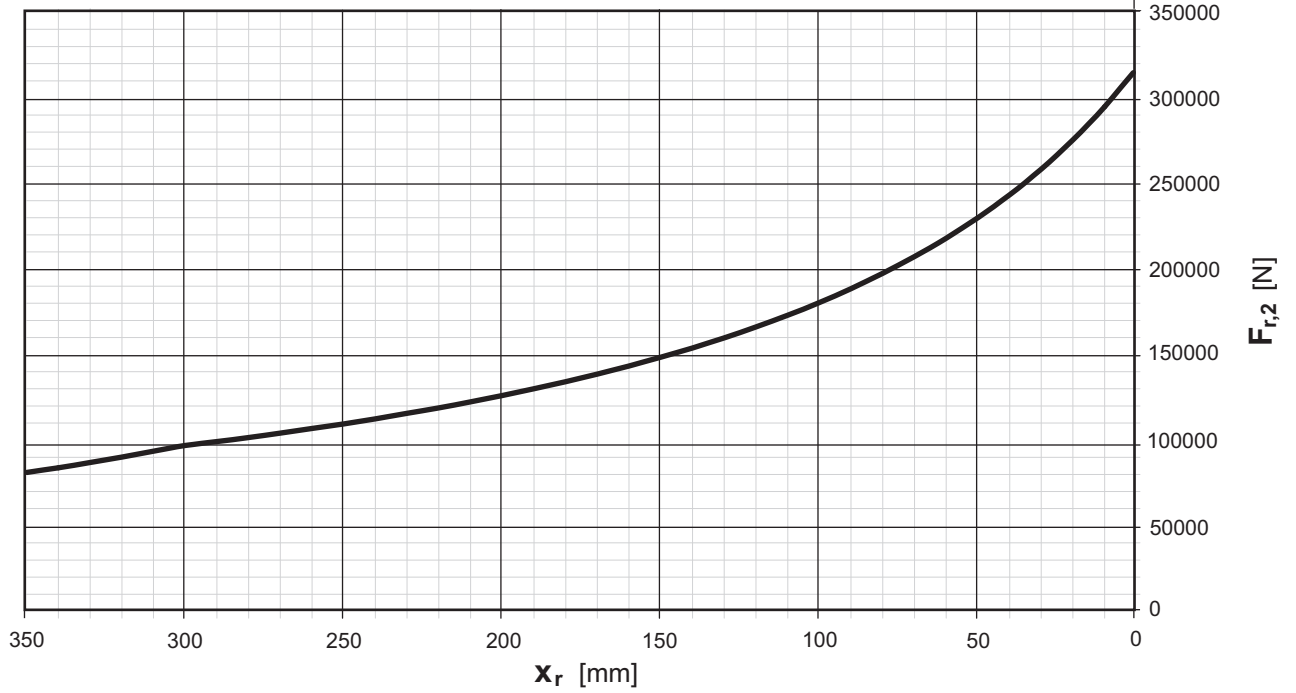
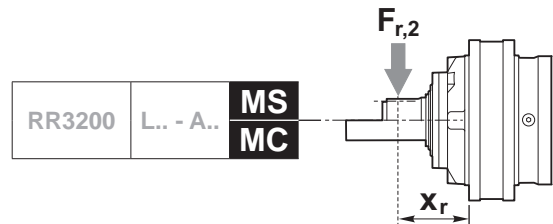

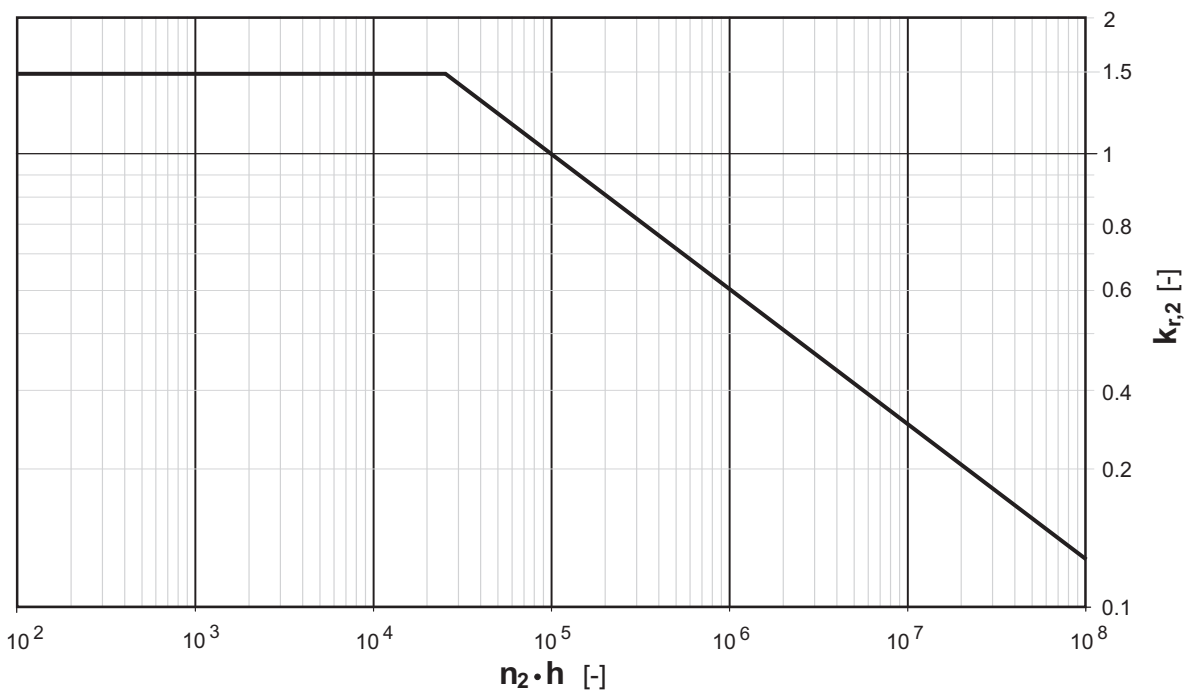
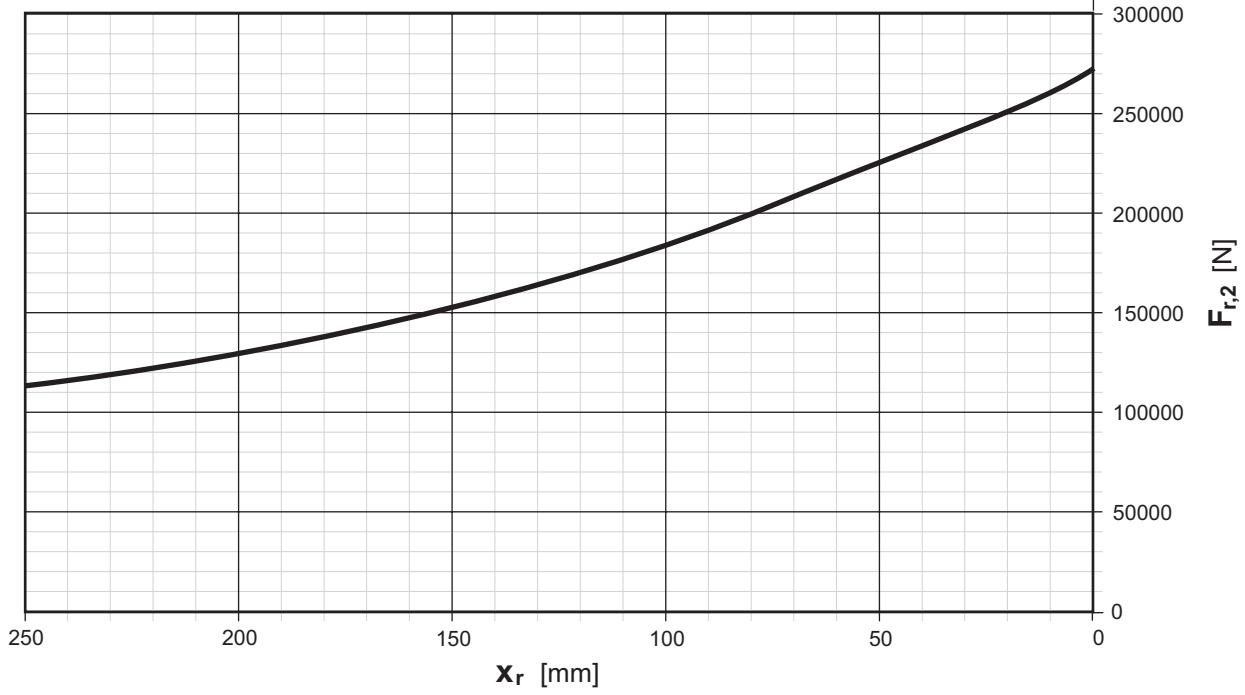
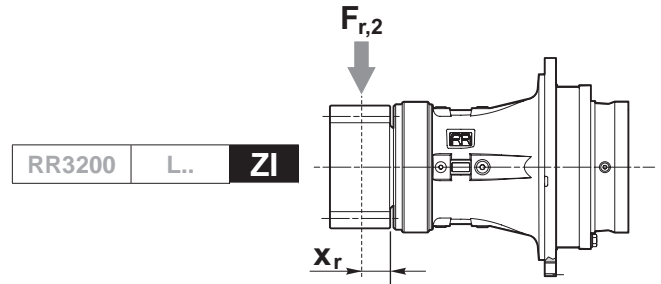



RR4000

IT EN DE FR ES PT

RR4000 L.. .. **i**



	i	T ₂ [Nm]						n _{1max} [min ⁻¹]	T _{2max} [Nm]	P _t [kW]
		n ₂ x h								
		10000 (10 ⁴)	25000 (2.5 · 10 ⁴)	50000 (5 · 10 ⁴)	100000 (10 ⁵)	500000 (5 · 10 ⁵)	1000000 (10 ⁶)			
RR4000 L1	4.17	47690	44030	43420	40070	26630	21630	1000	75000	58
	4.65	42370	38860	37830	34440	26490	21520	1000	75000	58
	5.29	41240	37090	32650	30310	25920	21050	1000	75000	58
	6.21	34480	29090	25580	24330	22040	20870	1000	75000	58
RR4000 L2	16.28	47690	44030	43420	40070	26630	21630	2000	75000	34
	18.41	47690	44030	43420	40070	26630	21630	2000	75000	34
	21.47	47690	43550	41740	40010	26630	21630	2000	75000	34
	23.91	42370	38860	37830	34440	26490	21520	2000	75000	34
	29.17	39750	36930	35390	33920	26490	21520	2000	75000	34
	33.21	41240	37090	32650	30310	25920	21050	2000	75000	34
	38.98	34480	29090	25580	24330	22040	20870	2000	75000	34
RR4000 L3	55.35	47690	44030	43420	40070	26630	21630	3500	75000	25
	62.61	47690	44030	43420	40070	26630	21630	3500	75000	25
	73.66	47690	44030	43420	40070	26630	21630	3500	75000	25
	81.39	45970	43460	41650	39920	26630	21630	3500	75000	25
	92.07	47690	44030	43420	40070	26630	21630	3500	75000	25
	106.80	45620	43120	41310	39580	26630	21630	3500	75000	25
	124.50	47690	43550	41740	40010	26630	21630	3500	75000	25
	138.70	42370	38860	37830	34440	26490	21520	3500	75000	25
	167.40	41530	38860	37640	34440	26490	21520	3500	75000	25
	204.18	39750	36930	35390	33920	26490	21520	3500	75000	25
	232.46	41240	37090	32650	30310	25920	21050	3500	75000	25
	272.86	34480	29090	25580	24330	22040	20870	3500	75000	25
RR4000 L4	188.18	47690	44030	43420	40070	26630	21630	3500	75000	20
	221.38	47690	44030	43420	40070	26630	21630	3500	75000	20
	250.43	47690	44030	43420	40070	26630	21630	3500	75000	20
	276.73	47690	44030	43420	40070	26630	21630	3500	75000	20
	313.04	47690	44030	43420	40070	26630	21630	3500	75000	20
	363.13	47690	44030	43420	40070	26630	21630	3500	75000	20
	387.42	47690	44030	43420	40070	26630	21630	3500	75000	20
	460.36	47690	44030	43420	40070	26630	21630	3500	75000	20
	515.60	47690	44030	43420	40070	26630	21630	3500	75000	20
	569.74	45970	43460	41650	39920	26630	21630	3500	75000	20
	644.50	47690	44030	43420	40070	26630	21630	3500	75000	20
	747.62	45620	43120	41310	39580	26630	21630	3500	75000	20
	871.51	47690	43550	41740	40010	26630	21630	3500	75000	20
	970.92	42370	38860	37830	34440	26490	21520	3500	75000	20
	1171.80	41530	38860	37640	34440	26490	21520	3500	75000	20
	1282.91	36470	33370	31980	30650	26630	21630	3500	75000	20
	1429.24	39750	36930	35390	33920	26490	21520	3500	75000	20
	1627.22	41240	37090	32650	30310	25920	21050	3500	75000	20
	1910.05	34480	29090	25580	24330	22040	20870	3500	75000	20

RR4000 A.. .. **i**

	i	T ₂ [Nm]						n _{1max} [min ⁻¹]	T _{2max} [Nm]	P _t [kW]	
		n ₂ x h									
		10000 (10 ⁴)	25000 (2.5 · 10 ⁴)	50000 (5 · 10 ⁴)	100000 (10 ⁵)	500000 (5 · 10 ⁵)	1000000 (10 ⁶)				
	1/...										
RR4000 A2 (A)	11.38	25480	25480	21110	17150	10580	8590	2500	60720	40	
	12.68	28390	28030	22770	18490	11410	9270	2500	67650	40	
	14.44	32320	30700	24930	20250	12500	10150	2500	75000	40	
	16.95	34480	29090	25580	22660	13980	11360	2500	75000	40	
	20.51	33000	29090	25580	21810	13460	10930	2500	75000	40	
	24.17	29730	29090	25350	20590	12700	10320	2500	75000	40	
	(B)	11.56	29110	28300	25070	20360	12560	10210	2500	72880	45
		12.88	31890	31530	27040	21960	13550	11010	2500	75000	45
		14.66	35900	35900	29610	24050	14840	12050	2500	75000	45
		17.21	34480	29090	25580	24330	16600	13480	2500	75000	45
		19.68	34480	29090	25580	24330	16810	13650	2500	75000	45
		25.42	29100	29090	25580	24330	16710	13570	2500	75000	45
	(C)	10.27	47690	44030	43420	40070	26620	21620	2000	75000	58
		11.45	42370	38860	37830	34440	26490	21520	2000	75000	58
		13.22	47690	44030	43420	40070	26590	21600	2000	75000	58
		14.72	42370	38860	37830	34440	26490	21520	2000	75000	58
		15.94	43740	43740	43420	40070	26250	21320	2000	75000	58
		17.75	42370	38860	37830	34440	26490	21520	2000	75000	58
		20.21	41240	37090	32650	30310	25920	21050	2000	75000	58
		23.73	34480	29090	25580	24330	22040	20870	2000	75000	58
	RR4000 A3 (A)	43.83	33920	26900	21850	17750	10950	8900	3500	75000	28
49.58		38370	29330	23820	19350	11940	9700	3500	75000	28	
57.79		42980	32650	26520	21540	13290	10800	3500	75000	28	
64.38		42370	35220	28600	23230	14340	11640	3500	75000	28	
78.53		39750	36930	32870	26700	16470	13380	3500	75000	28	
89.41		41240	37090	32650	29240	18040	14650	3500	75000	28	
104.73		41240	37090	32650	28790	17770	14430	3500	75000	28	
122.94		34480	29090	25580	24330	19880	16140	3500	75000	28	
132.83		39030	37090	32650	27590	17020	13830	3500	75000	28	
155.92		34480	29090	25580	24330	19040	15470	3500	75000	28	
(B)		44.40	47690	44030	43420	40070	26630	21630	2500	75000	32
		50.22	47690	44030	43420	40070	26630	21630	2500	75000	32
		60.77	47690	44030	43420	40070	26630	21630	2500	75000	32
		71.61	47690	44030	43420	40070	26500	21520	2500	75000	32
		83.48	47690	43550	41740	40010	26630	21630	2500	75000	32
		93.00	42370	38860	37830	34440	26490	21520	2500	75000	32
		113.43	39750	36930	35390	33920	26490	21520	2500	75000	32
		129.14	41240	37090	32650	30310	25920	21050	2500	75000	32
		151.59	34480	29090	25580	24330	22040	20870	2500	75000	32
		RR4000 A4	168.56	47690	44030	43420	40070	26630	21630	3500	75000
	198.31		47690	44030	43420	40070	26630	21630	3500	75000	22
247.89	47690		44030	43420	40070	26630	21630	3500	75000	22	
294.63	47690		44030	43420	40070	26630	21630	3500	75000	22	
368.29	47690		44030	43420	40070	26630	21630	3500	75000	22	
427.21	45620		43120	41310	39580	26630	21630	3500	75000	22	
498.01	47690		43550	41740	40010	26630	21630	3500	75000	22	
554.81	42370		38860	37830	34440	26490	21520	3500	75000	22	
669.60	41530		38860	37640	34440	26490	21520	3500	75000	22	
816.71	39750		36930	35390	33920	26490	21520	3500	75000	22	
929.84	41240		37090	32650	30310	25920	21050	3500	75000	22	
1091.45	34480		29090	25580	24330	22040	20870	3500	75000	22	



RR4000

IT EN DE FR ES PT

RR4000 L.. .. i



L1

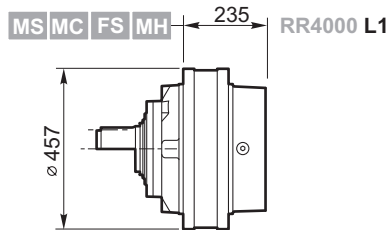

L2

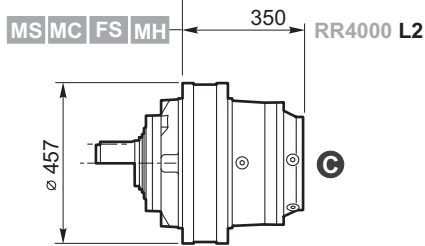

L3

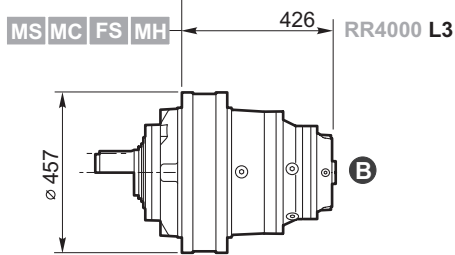

L4

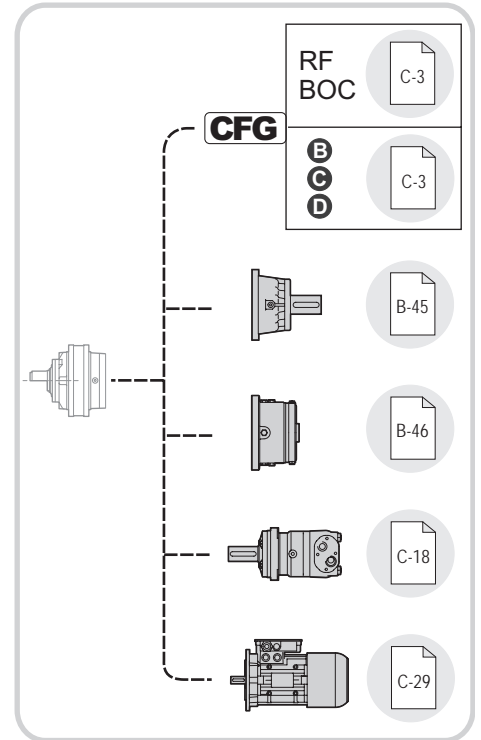
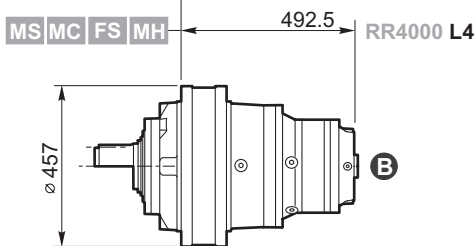

ZI 364 RR4000 L2

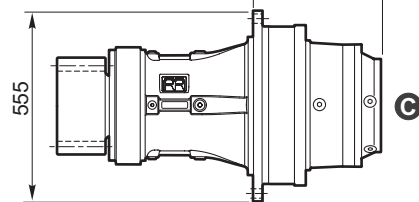

ZI 440 RR4000 L3

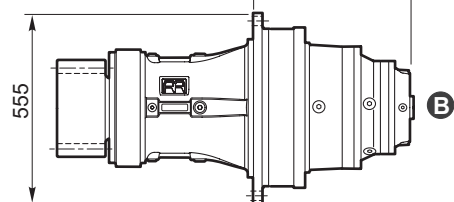

ZI 506.5 RR4000 L4

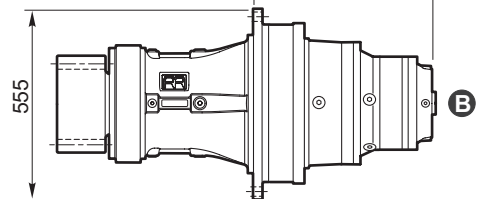

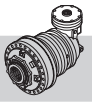

RR4000 A.. .. i

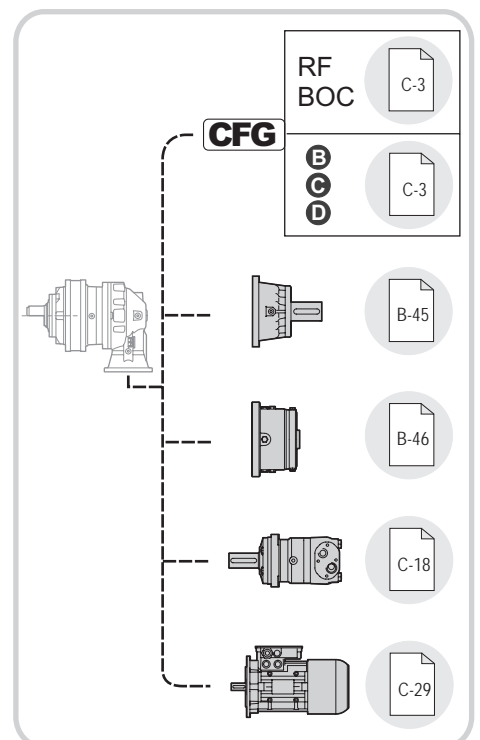
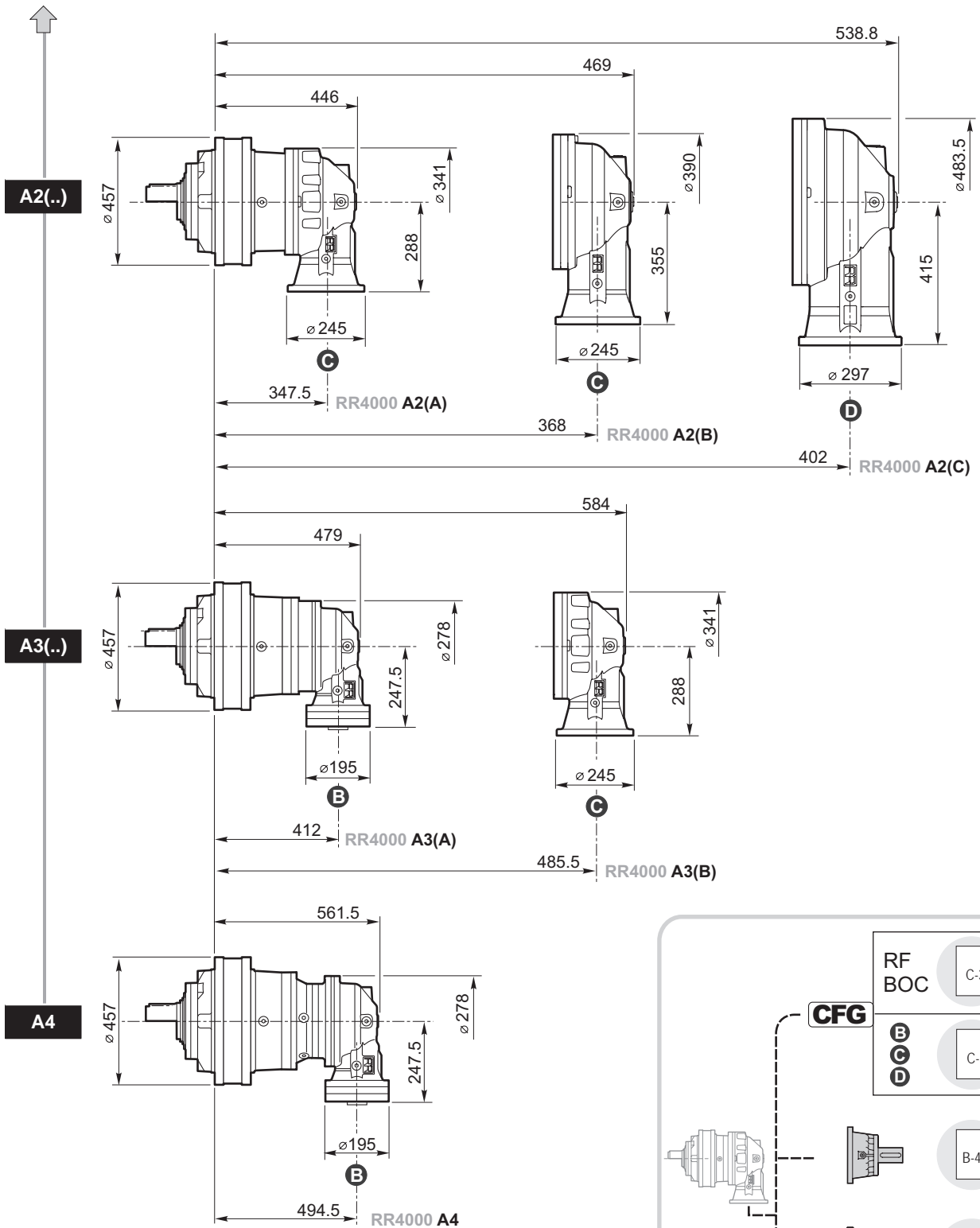

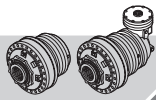

RR4000

IT EN DE FR ES PT

RR4000	L..	MS	i
RR4000	A..		i

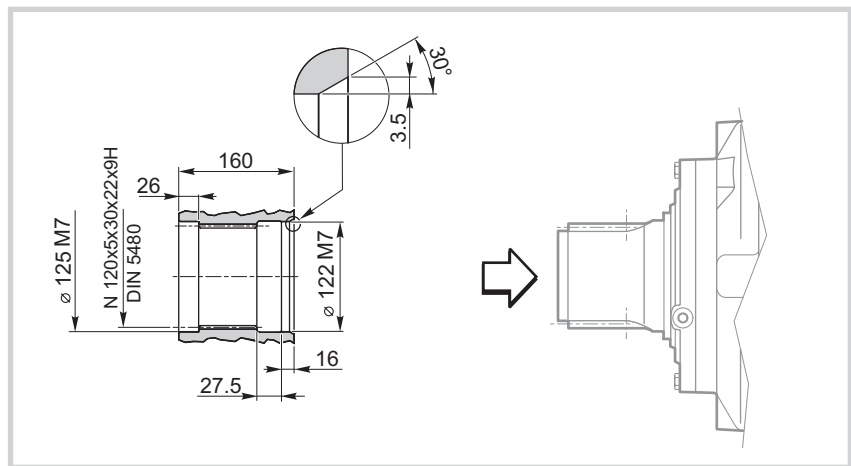
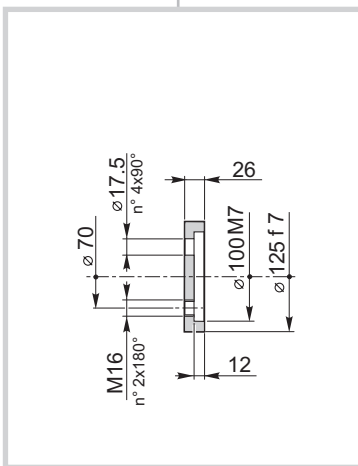
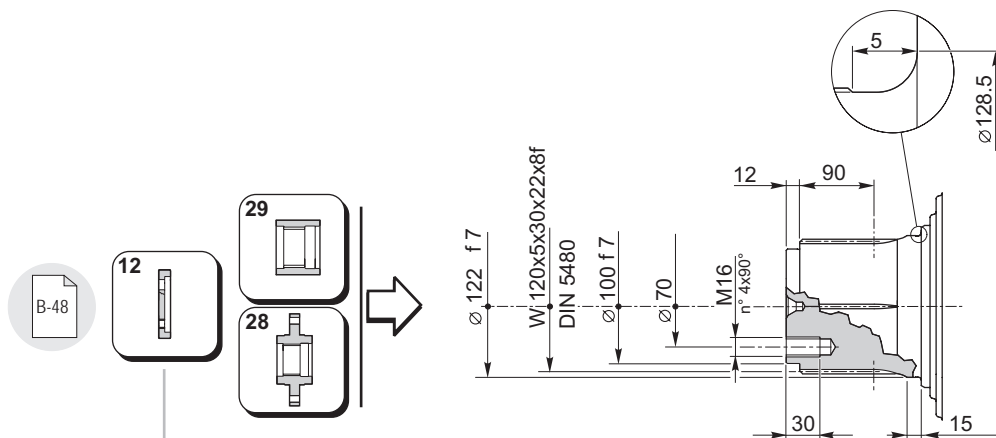
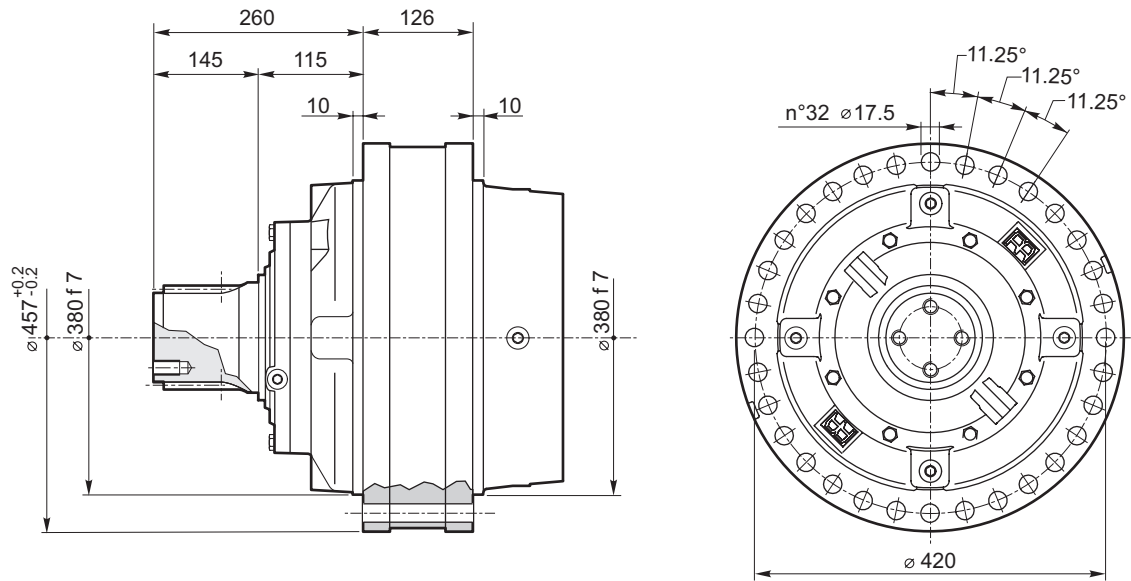

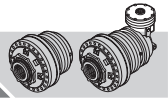

RR4000	L..	MC	i
RR4000	A..		i

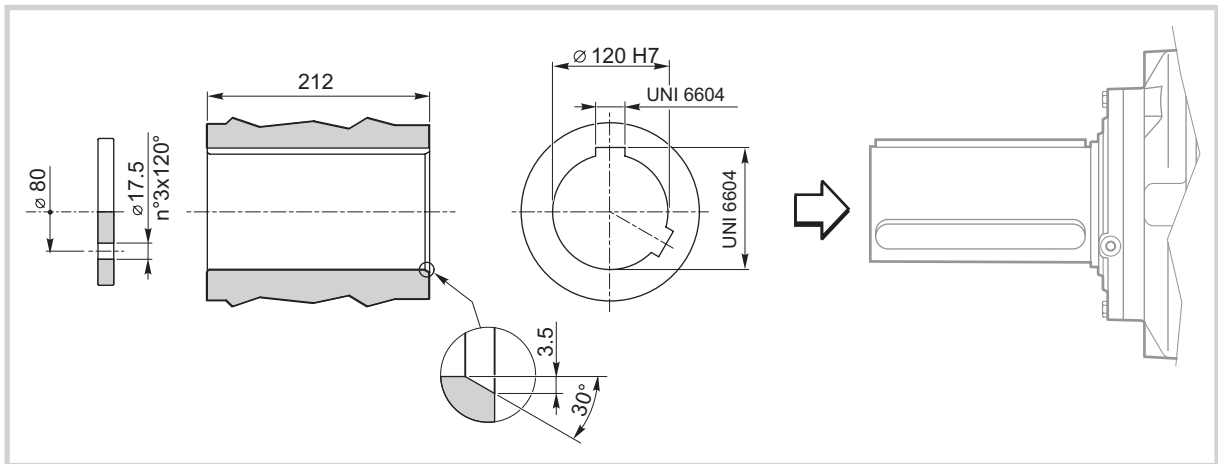
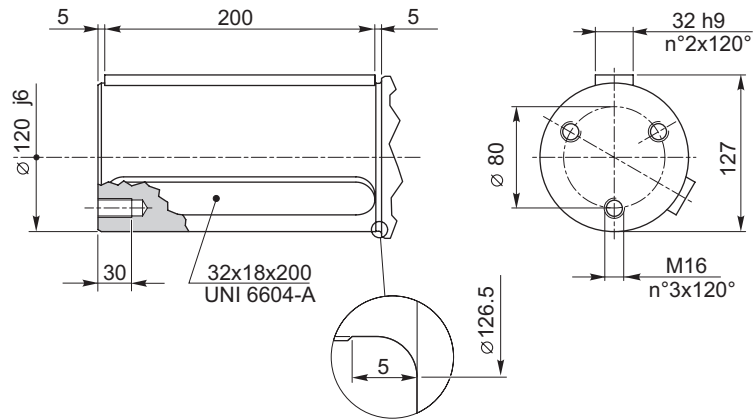
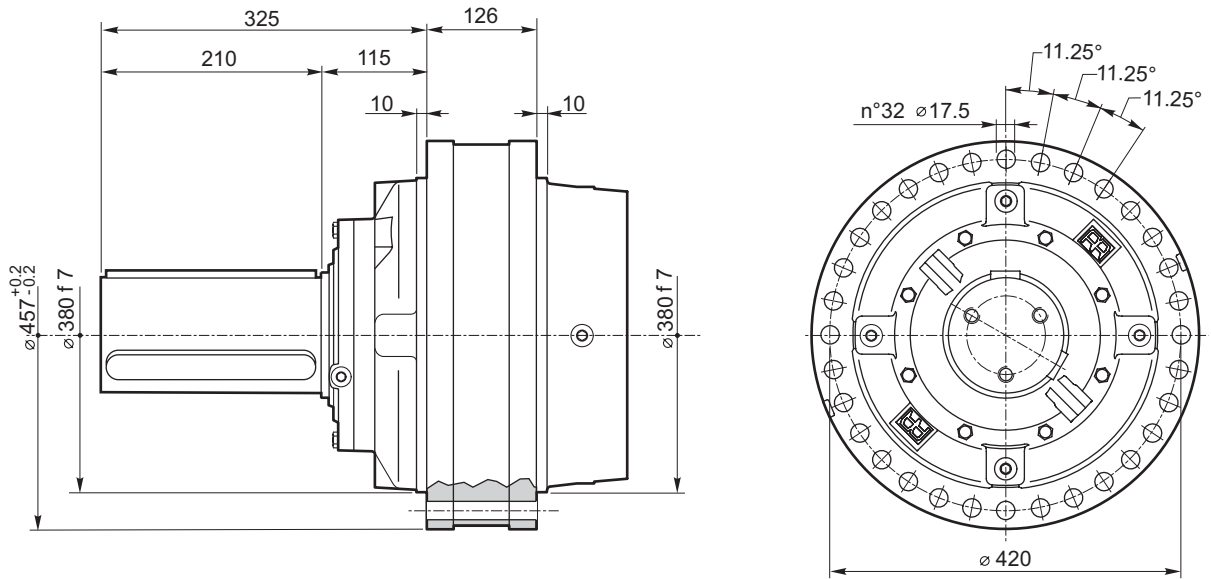

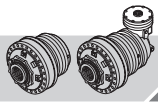

RR4000

IT EN DEFRES PT

RR4000	L..	FS	i
RR4000	A..		i

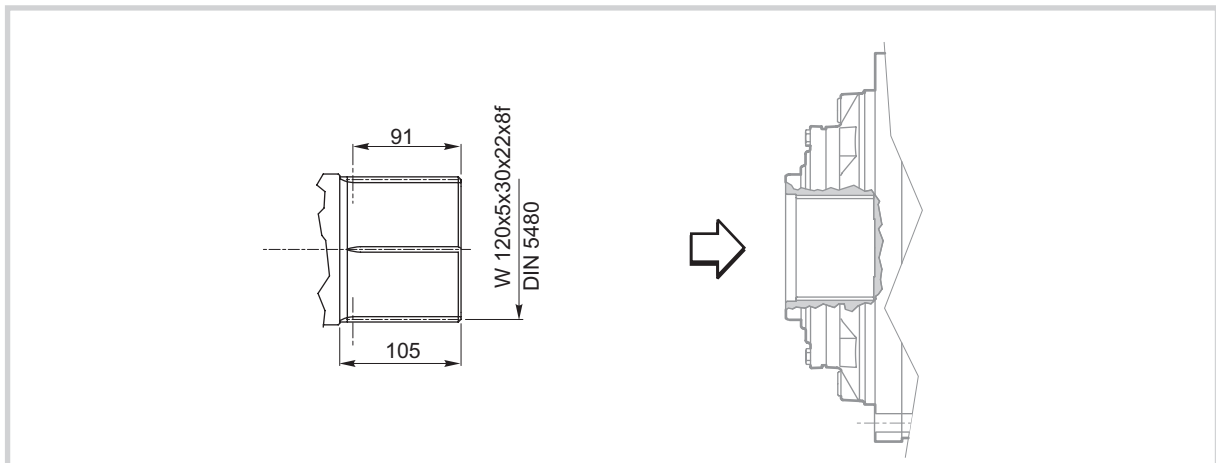
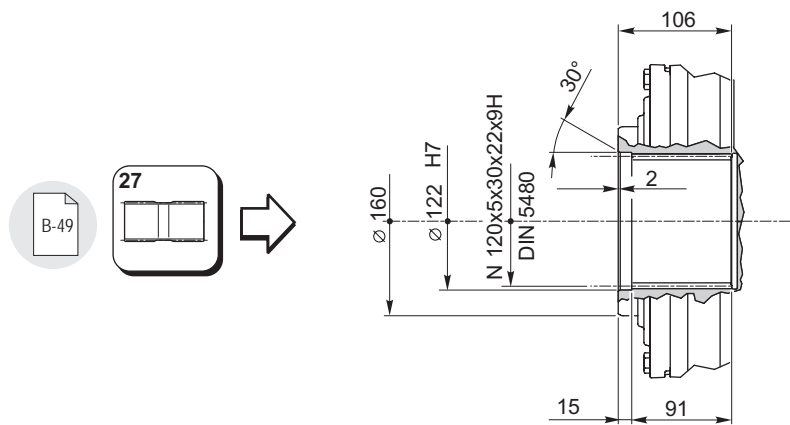
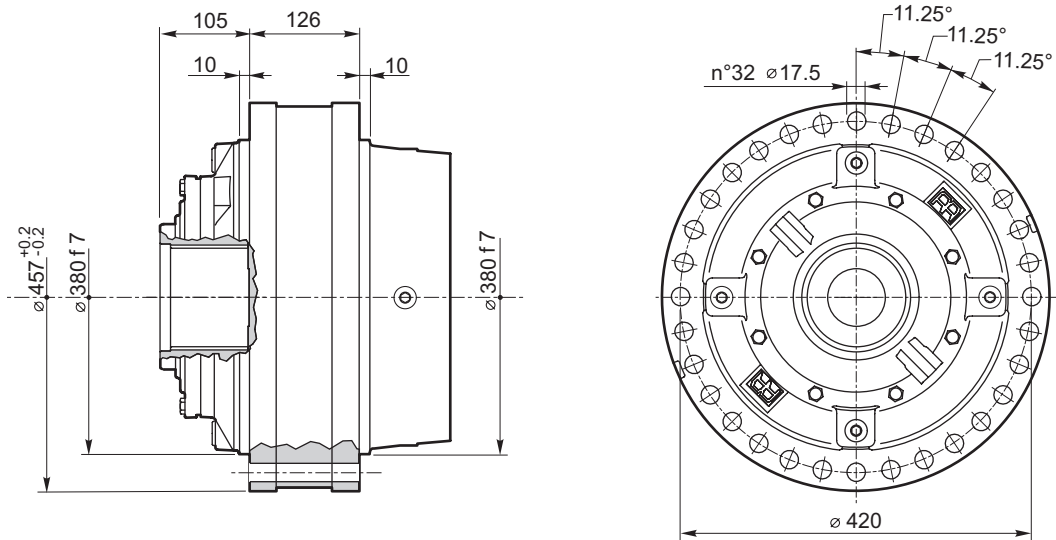

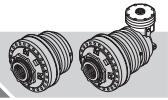

RR4000	L..	MH	i
RR4000	A..		i

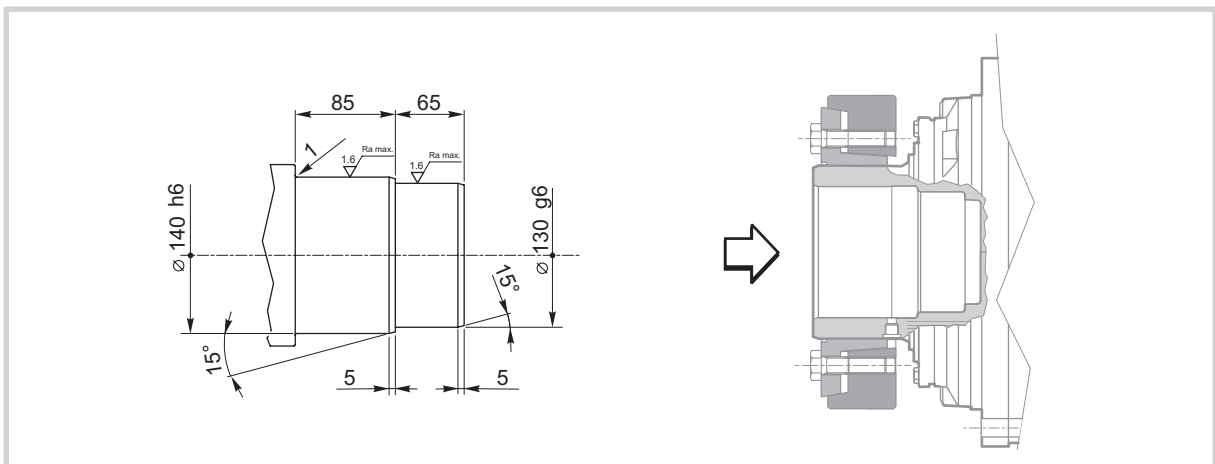
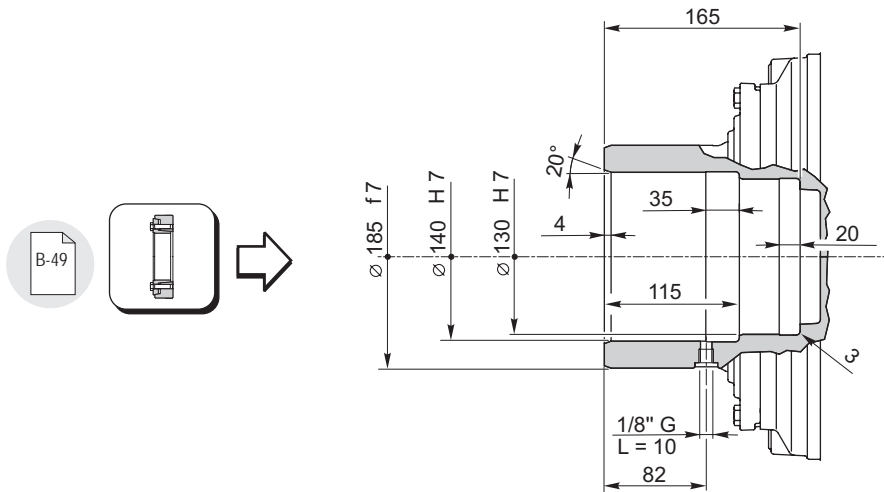
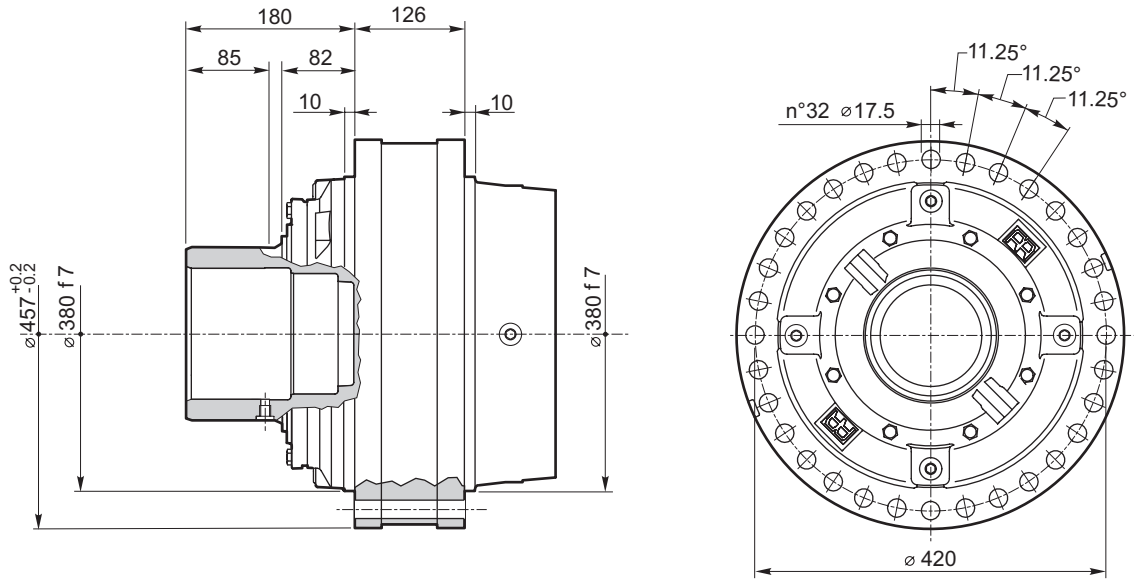



RR4000

IT EN DE FR ES PT

RR4000 L.. ZI i

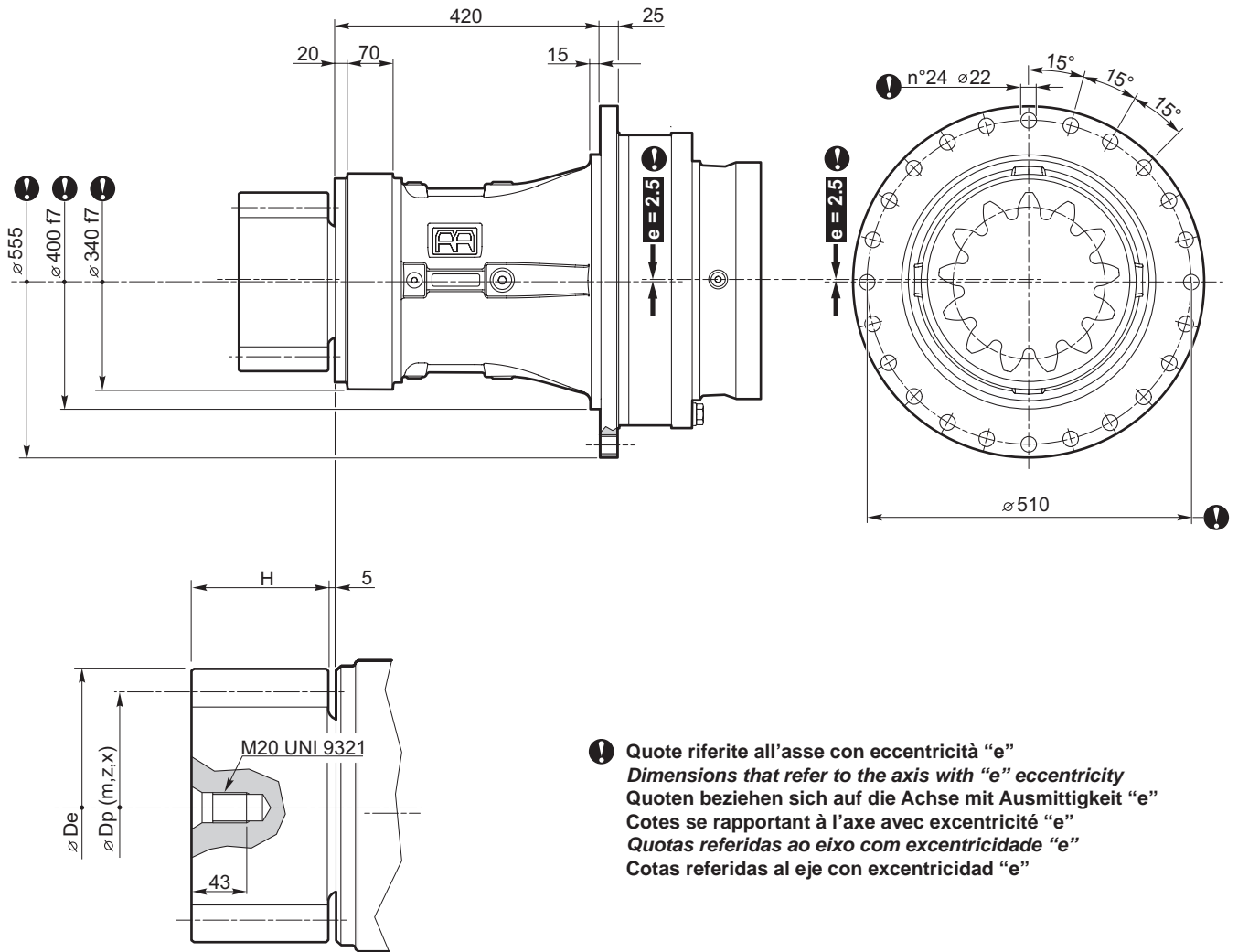

! Quote riferite all'asse con eccentricità "e"
 Dimensions that refer to the axis with "e" eccentricity
 Quoten beziehen sich auf die Achse mit Ausmittigkeit "e"
 Cotes se rapportant à l'axe avec excentricité "e"
 Quotas referidas ao eixo com excentricidade "e"
 Cotas referidas al eje con excentricidad "e"

	m	z	x	H	Dp	De	code
	16	14	0.5	150	224	272	03-644
	18	14	0.5	150	252	306	03-643
	20	12	0.5	150	240	300	03-645

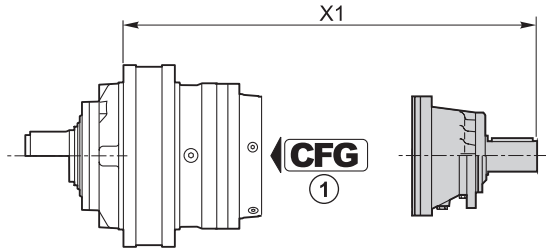
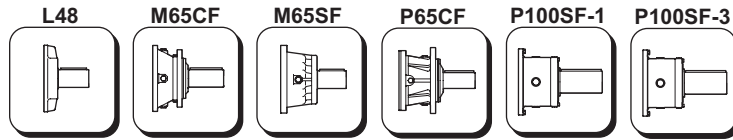
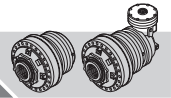

	CFG ①		code	X1
RR4000 L1	—	P100SF-3	154F3324	612
RR4000 L2	—	P65CF	154-2404	662
RR4000 L3	RF	M65SF	154B4249	610.5
	RF	M65CF	154-2407	633.5
	BOC	L48	154B3989	547.3
RR4000 L4	RF	M65SF	154B4249	677
	RF	M65CF	154-2407	700
	BOC	L48	154B3989	613.8

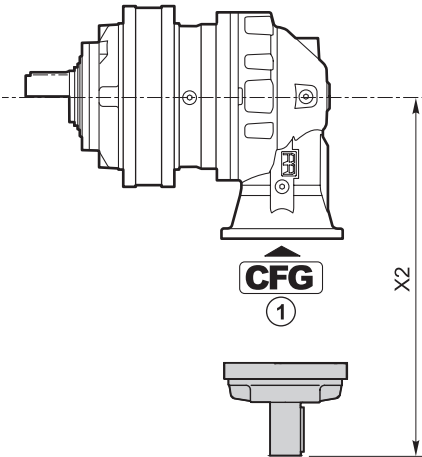

	CFG ①		code	X2
RR4000 A2(A)	—	P65CF	154-2404	600
RR4000 A2(B)	—	P65CF	154-2404	667
RR4000 A2(C)	—	P100SF-1	154F3322	791.5
RR4000 A3(A)	—	L48	154B3989	347.8
RR4000 A3(B)	—	P65CF	154-2404	600
RR4000 A4	BOC	L48	154B3989	347.8

CFG	
RF BOC	
B C D	

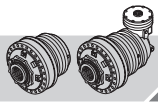

RR4000

IT EN DE FR ES PT

RF170-290



RF5/..

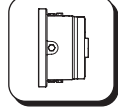

RFF5/..

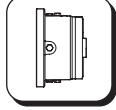

RF2/..

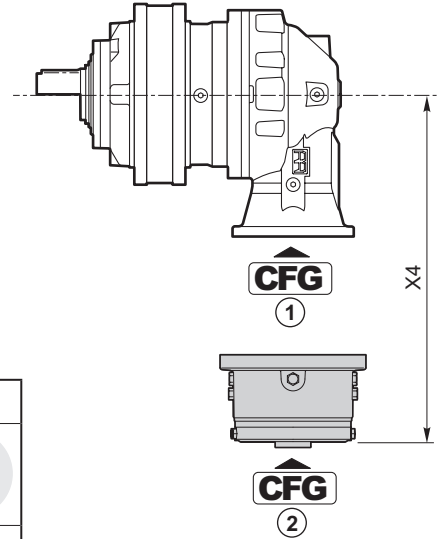
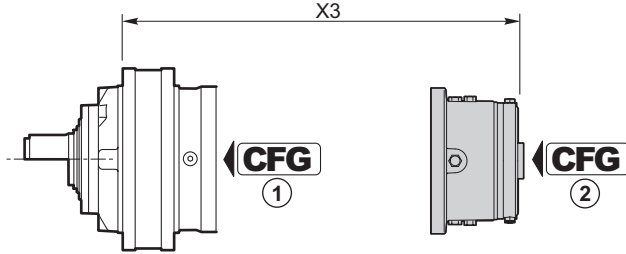
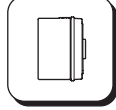

RF170-290	CFG ①	T _f [Nm]	CFG ②			
			C			
			code	X3	X4	
RR4000 L2	RF	1700	154B9766M2	547	—	
		2000	154B9767M2			
		2300	154B9768M2			
		2900	154B9769M2			
RR4000 A2(A)	—	1700	154B9766M3	—	485	
		2000	154B9767M3			
		2300	154B9768M3			
		2900	154B9769M3			
RR4000 A2(B)	—	1700	154B9766M3	—	552	
		2000	154B9767M3			
		2300	154B9768M3			
		2900	154B9769M3			
RR4000 A3(B)	—	1700	154B9766M3	—	485	
		2000	154B9767M3			
		2300	154B9768M3			
		2900	154B9769M3			

CFG	
RF BOC	C-3
B C D	C-3

RF5/..	CFG ①	T _f [Nm]	CFG ②						
			B			OMTS 12/24 z16	OMVS 10/20 z16		
			code	X3	X4	code	code	X3	X4
RR4000 L3	RF	210	154-2872	516.3	—	154-2879	154-2886	520	—
		290	154-2873			154-2880	154-2887		
		430	154-2874			154-2881	154-2888		
		650	154-2875			154-2882	154-2889		
		850	154-2876			154-2883	154-2890		
		1100	154-2877			154-2884	154-2891		
		1300	154-2878			154-2885	154-2892		
RR4000 L4	RF	210	154-2872	582.8	—	154-2879	154-2886	586.5	—
		290	154-2873			154-2880	154-2887		
		430	154-2874			154-2881	154-2888		
		650	154-2875			154-2882	154-2889		
		850	154-2876			154-2883	154-2890		
		1100	154-2877			154-2884	154-2891		
		1300	154-2878			154-2885	154-2892		



RFF5/..	CFG ①	T _f [Nm]	CFG ②						
			B			OMTS 12/24 z16	OMVS 10/20 z16		
			code	X3	X4	code	code	X3	X4
RR4000 A3(A)	RF	210	154-2893	—	316.6	154-5338	154-5345	—	320.5
		290	154-2894			154-5339	154-5346		
		430	154-2895			154-5340	154-5347		
		650	154-2896			154-5341	154-5348		
		850	154-2897			154-5342	154-5349		
		1100	154-2898			154-5343	154-5350		
RR4000 A4	RF	210	154-2893	—	316.6	154-5338	154-5345	—	320.5
		290	154-2894			154-5339	154-5346		
		430	154-2895			154-5340	154-5347		
		650	154-2896			154-5341	154-5348		
		850	154-2897			154-5342	154-5349		
		1100	154-2898			154-5343	154-5350		
		1300	154-2899			154-5344	154-5351		

CFG	
RF	
B C D	

RF2/..	CFG ①	T _f [Nm]	CFG ②								
			B			OMP/OMR SAE A 2B Ø 25	OMP/OMR SAE A 2B 1" 6B	OMP/OMR SAE A 4B Ø 25	OMP/OMR SAE A 4B 1" 6B		
			code	X3	X4	code	code	code	code	X3	X4
RR4000 L3	RF	70	154B9195	488.8	—	154B9195M10	—	154B9195M16	154B9195M17	478.8	—
		140	154B9196			154B9196M10	—	154B9196M16	154B9196M17		
		210	154B9197			154B9197M10	—	154B9197M16	154B9197M17		
		320	154B9198			154B9198M10	—	154B9198M16	154B9198M17		
		430	154B9199			154B9199M10	—	154B9199M16	154B9199M17		
		600	154B9200			154B9200M10	—	154B9200M16	154B9200M17		
RR4000 L4	RF	70	154-2345	555.3	—	154-2345M10	154-2345M11	154-2345M16	154-2345M17	545.3	—
		140	154-2346			154-2346M10	154-2346M11	154-2346M16	154-2346M17		
		210	154-2347			154-2347M10	154-2347M11	154-2347M16	154-2347M17		
		320	154-2348			154-2348M10	154-2348M11	154-2348M16	154-2348M17		
		430	154-2349			154-2349M10	154-2349M11	154-2349M16	154-2349M17		
		600	154B9186			154B9186M10	154B9186M11	154B9186M16	154B9186M17		
RR4000 A3(A)	RF	70	154F2991	—	285.3						
		140	154F1890								
		210	154F2961								
		320	154B3591								
		430	154B3592								
		600	154F2992								
RR4000 A4	RF	70	154F2991	—	285.3						
		140	154F1890								
		210	154F2961								
		320	154B3591								
		430	154B3592								
		600	154F2992								

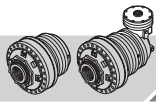

RR4000

IT EN DE FR ES PT

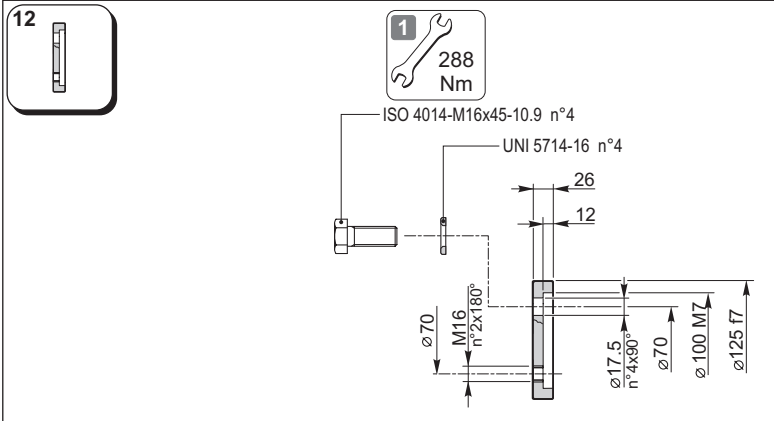

154F6031

Materiale / Material / Material / Matériau / Material / Material:
Acciaio / Steel / Stahl / Acier / Acero / Aço
EN 10083-1-42CrMo4+QT (1.7225)

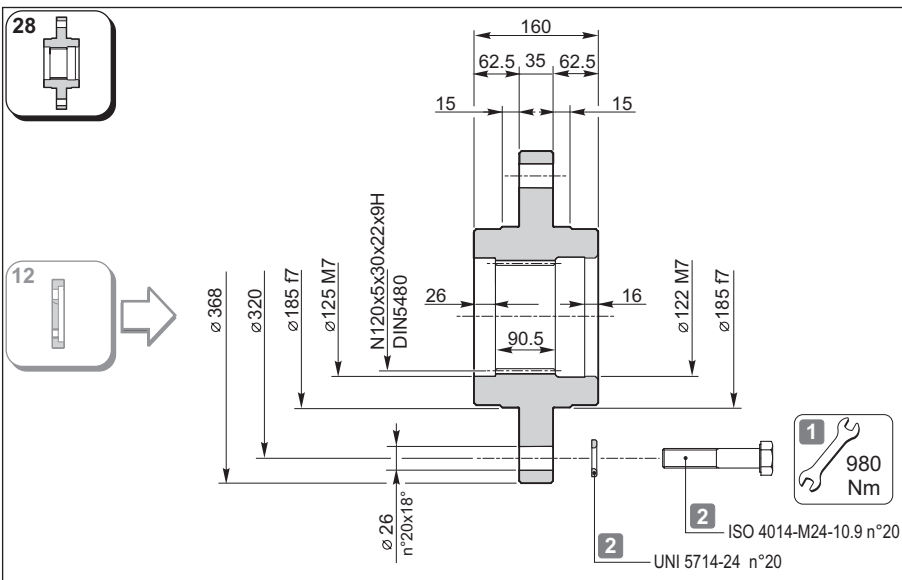

154F6049

Materiale / Material / Material / Matériau / Material / Material:
Acciaio / Steel / Stahl / Acier / Acero / Aço
EN 10083-1-C40 (1.1186)

Trattamento termico:
 Tempra ad induzione secondo UNI 10932 su scanalato interno

Heat treatment:
 Induction hardening according to UNI 10932 on internal spline

Wärmebehandlung:
 Induktionshärtung nach UNI 10932 an interner Nut

Traitement thermique :
 Trempe par induction conformément à la norme UNI 10932 sur cannelé interne

Tratamiento térmico:
 Temple por inducción según UNI 10932 en acanalado interno

Tratamento térmico:
 Tempra por indução segundo UNI 10932 sobre ranhuras internas

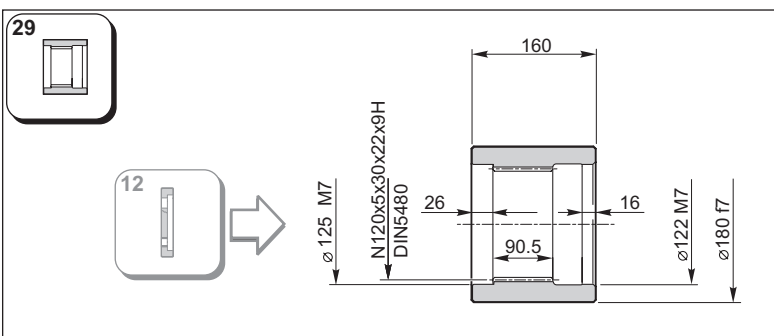

154F6057

Materiale / Materiale / Material / Matériau / Material / Material:
Acciaio / Steel / Stahl / Acier / Acero / Aço
EN 10083-1-42CrMo4+QT (1.7225)

Trattamento termico:
 Tempra ad induzione secondo UNI 10932 su scanalato interno

Heat treatment:
 Induction hardening according to UNI 10932 on internal spline

Wärmebehandlung:
 Induktionshärtung nach UNI 10932 an interner Nut

Traitement thermique :
 Trempe par induction conformément à la norme UNI 10932 sur cannelé interne

Tratamiento térmico:
 Temple por inducción según UNI 10932 en acanalado interno

Tratamento térmico:
 Tempra por indução segundo UNI 10932 sobre ranhuras internas

1 Coefficiente d'attrito medio considerato: 0.14
 Average friction coefficient considered: 0.14
 Durchschnittlicher berücksichtigter Reibungskoeffizient: 0.14
 Coefficient de frottement moyen considéré: 0.14
 Coeficiente medio de fricción considerado: 0.14
 Coeficiente de atrito médio considerado: 0.14

2 Componenti non forniti da Reggiana Riduttori
 Components not supplied by Reggiana Riduttori
 Nicht von Reggiana Riduttori gelieferte Komponenten
 Parties pas fournies par Reggiana Riduttori
 Componentes no suministrados por Reggiana Riduttori
 Componentes não fornecidos por Reggiana Riduttori

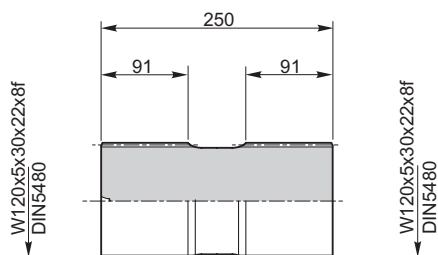
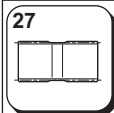
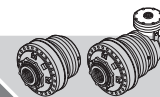

$T_{2max} =$
60000 Nm

Materiale / Material / Material / Matériau / Material / Material:
Acciaio / Steel / Stahl / Acier / Acero / Aço
EN 10083-1-42CrMo4+QT (1.7225)

154F6037

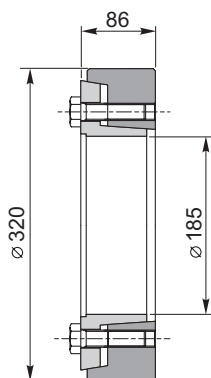
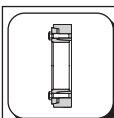

C-32

154F6066



$T_{2max} =$
xxxxxxx Nm

ATTENZIONE

Il valore di T_{2max} indicato costituisce una limitazione del valore relativo al riduttore, riportato nella tabella dei dati tecnici per ciascuna grandezza.

ATTENTION

The T_{2max} value indicated is a limit of the reduction gear value, given in the technical data table for each size.

ACHTUNG!

Der angegebene Wert T_{2max} stellt eine Einschränkung vom entsprechenden Wert am Untersetzungsgetriebe dar, der in der Tabelle mit den technischen Daten für jede Größe angegeben ist.

ATTENTION

Le valeur de T_{2max} indiquée représente une restriction de la valeur relative au réducteur et indiquée sur le tableau des caractéristiques techniques pour chaque grandeur.

ATENCIÓN

El valor de T_{2max} indicado constituye una limitación del valor referente al reductor, indicado en la tabla de los datos técnicos para cada talla.

ATENÇÃO

O valor T_{2max} indicado representa uma limitação do valor relativo ao redutor, indicado na tabela dos dados técnicos para cada grandeza.

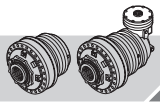

RR4000

IT EN DE FR ES PT

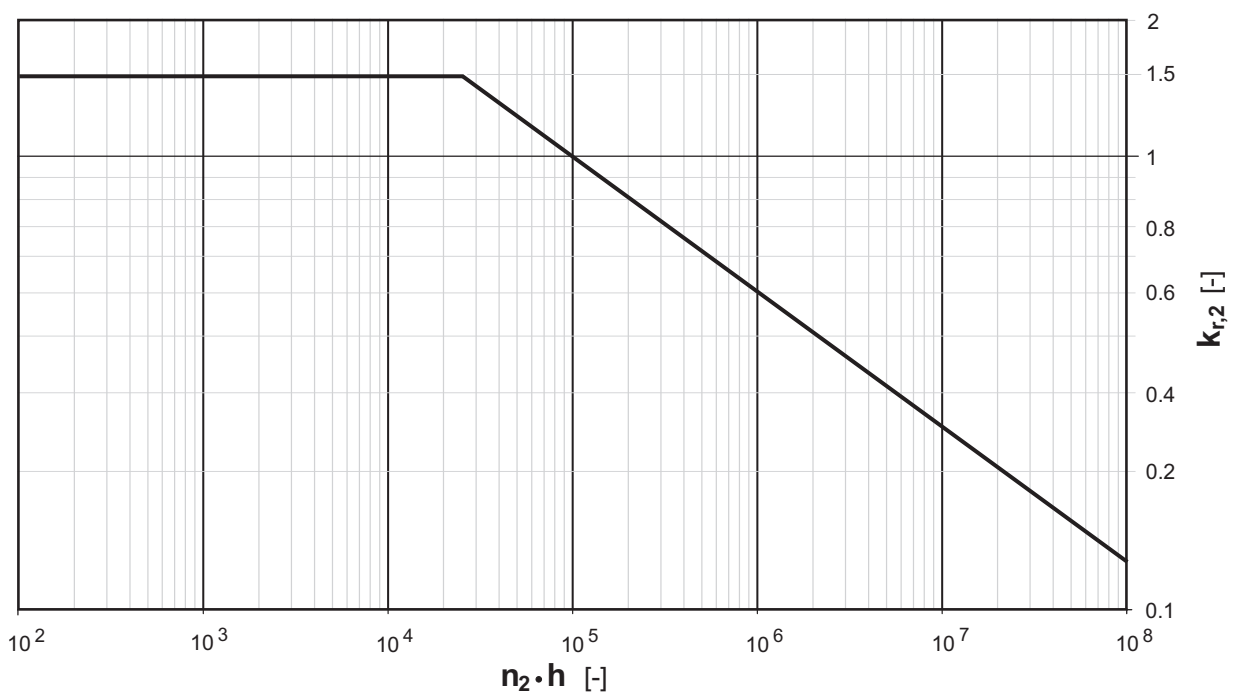
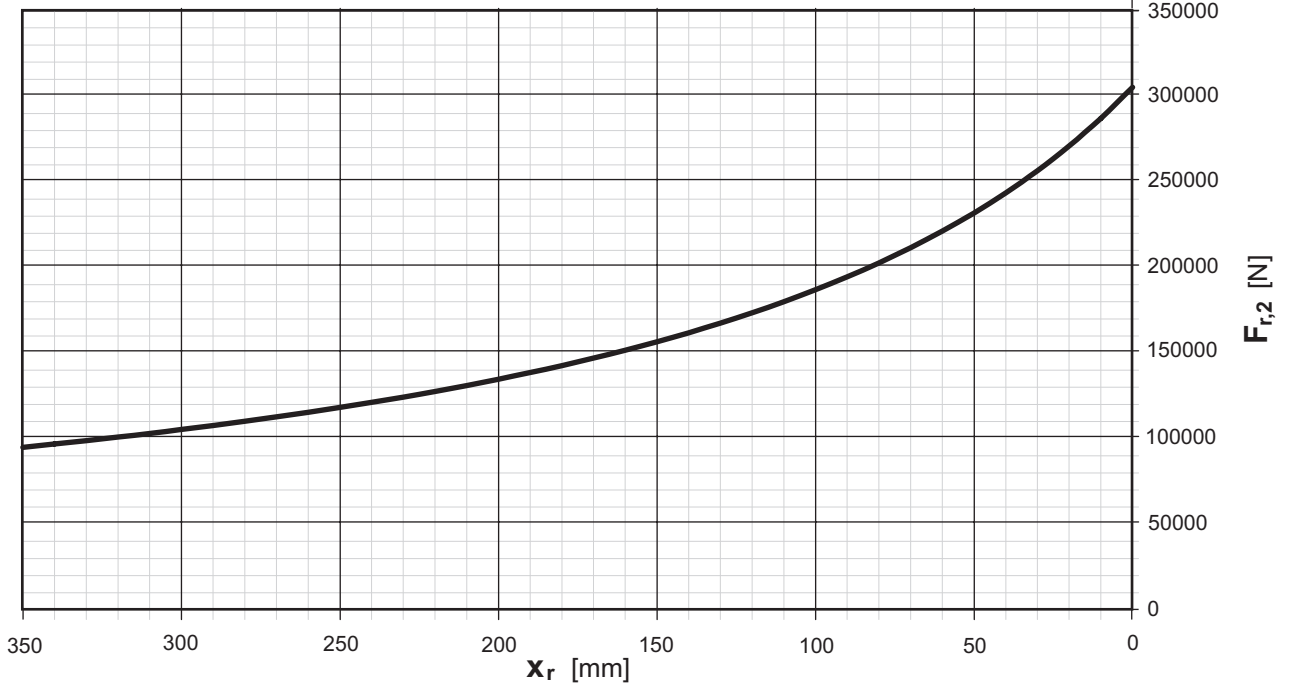
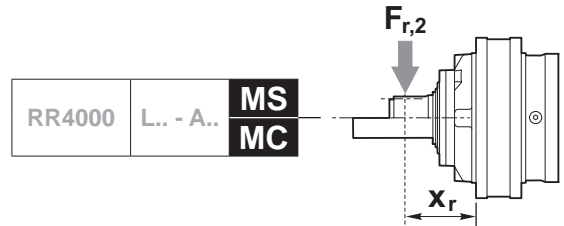

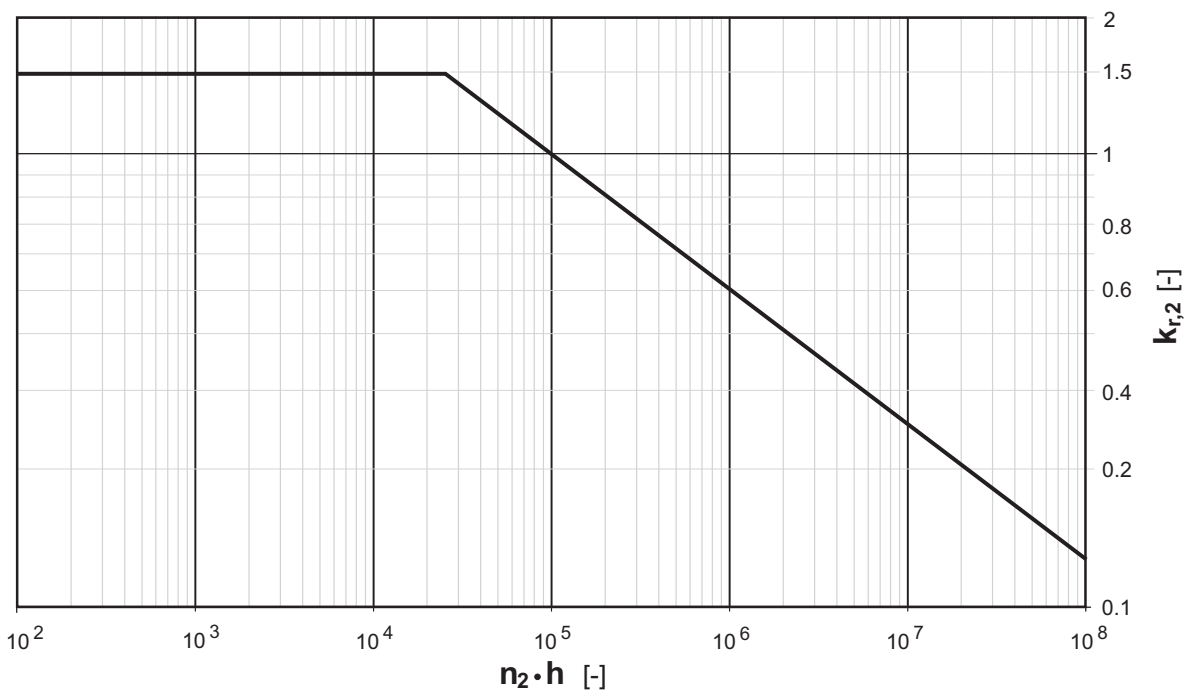
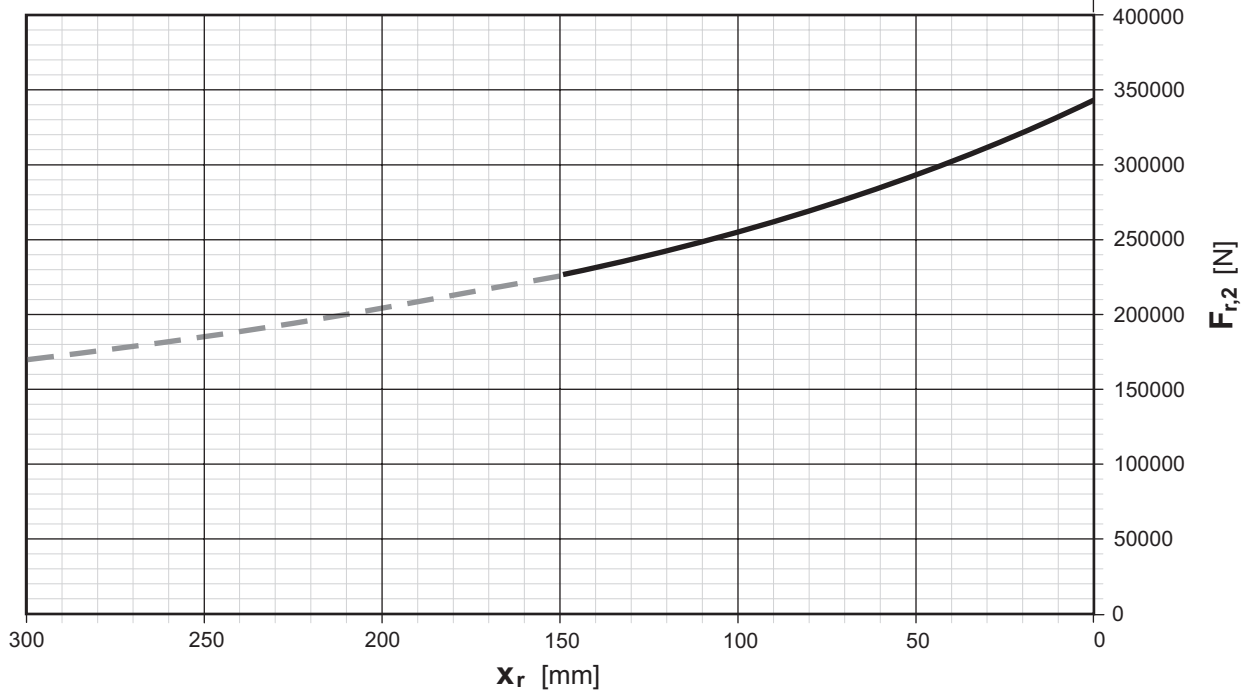
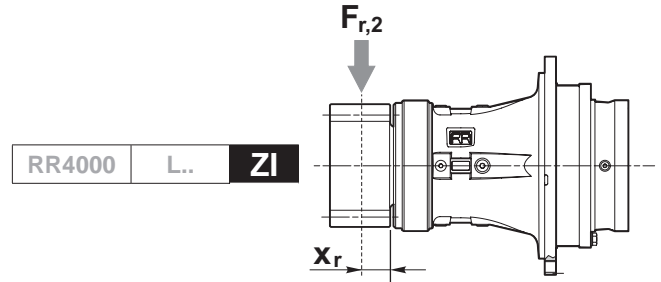



RR5200

IT EN DE FR ES PT

RR5200 L.. .. **i**



i	T ₂ [Nm]						n _{1max} [min ⁻¹]	T _{2max} [Nm]	P _t [kW]	
	n ₂ x h									
1/...	10000 (10 ⁴)	25000 (2.5 · 10 ⁴)	50000 (5 · 10 ⁴)	100000 (10 ⁵)	500000 (5 · 10 ⁵)	1000000 (10 ⁶)				
RR5200 L1	4.17	62150	57390	55540	51490	35510	28840	1000	92000	59
	4.84	55910	49540	43610	41380	34810	28270	1000	92000	59
	5.87	44070	37200	33370	31980	28970	27690	1000	92000	59
RR5200 L2	16.28	62150	57390	55540	51490	35510	28840	2000	92000	35
	18.41	62150	54150	51900	49740	35510	28840	2000	92000	35
	21.36	55910	49540	43610	41380	34810	28270	2000	92000	35
	24.90	55420	49540	43610	41380	34810	28270	2000	92000	35
	30.37	41060	38360	36760	35230	31920	28270	2000	92000	35
	36.80	44070	37200	33370	31980	28970	27690	2000	92000	35
RR5200 L3	55.35	62150	57390	55540	47170	29100	23640	3500	92000	25
	65.11	62150	57390	55540	45720	28210	22920	3500	92000	25
	73.66	62150	54150	51900	49740	30760	24980	3500	92000	25
	92.07	51610	48790	46760	44820	30380	24680	3500	92000	25
	106.81	55910	49540	43610	41380	33710	27380	3500	92000	25
	124.51	55420	49540	43610	41380	34810	28270	3500	92000	25
	144.43	55420	49540	43610	41380	34810	28270	3500	92000	25
	174.32	43140	40790	39090	37470	34580	28270	3500	92000	25
	212.61	41060	38360	36760	35230	31920	28270	3500	92000	25
	257.60	44070	37200	33370	31980	28970	27690	3500	92000	25
RR5200 L4	188.18	62150	57390	55540	47170	29100	23640	3500	92000	20
	221.38	62150	57390	55540	47170	29100	23640	3500	92000	20
	276.73	62150	57390	55540	47170	29100	23640	3500	92000	20
	325.57	62150	57390	55540	45720	28210	22920	3500	92000	20
	377.66	62150	57390	55540	45720	28210	22920	3500	92000	20
	427.21	62150	54150	51900	49740	30760	24980	3500	92000	20
	515.60	62150	54150	51900	49740	30760	24980	3500	92000	20
	644.50	51610	48790	46760	44820	30380	24680	3500	92000	20
	718.63	52450	49540	43610	41380	33060	26860	3500	92000	20
	871.58	55420	49540	43610	41380	34810	28270	3500	92000	20
	1011.03	55420	49540	43610	41380	34810	28270	3500	92000	20
	1220.21	43140	40790	39090	37470	34580	28270	3500	92000	20
	1488.29	41060	38360	36760	35230	31920	28270	3500	92000	20
	1803.20	44070	37200	33370	31980	28970	27690	3500	92000	20

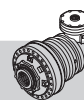

RR5200 A.. .. i



	i	T ₂ [Nm]						n _{1max} [min ⁻¹]	T _{2max} [Nm]	P _t [kW]
		n ₂ x h								
		10000 (10 ⁴)	25000 (2.5 · 10 ⁴)	50000 (5 · 10 ⁴)	100000 (10 ⁵)	500000 (5 · 10 ⁵)	1000000 (10 ⁶)			
RR5200 A2 (A)	11.38	25480	25480	21110	17150	10580	8590	2500	60720	41
	13.21	29560	28840	23420	19030	11740	9540	2500	70470	41
	16.00	35820	32980	26790	21760	13430	10910	2500	85400	41
	19.36	31160	31160	25790	20950	12930	10500	2500	85380	41
	22.81	28060	28060	24350	19780	12200	9910	2500	85370	41
	(B)									
	11.56	29110	28300	25070	20360	12560	10210	2500	72880	46
	13.41	33000	32840	27810	22590	13940	11320	2500	84550	46
	16.25	39780	37200	31810	25840	15940	12950	2500	92000	46
	18.58	35820	35820	32210	26170	16150	13110	2500	92000	46
	24.00	27470	27470	27470	26010	16050	13040	2500	92000	46
	(C)									
	10.27	62150	57390	53100	43130	26620	21620	2000	81010	58
	11.92	55910	49540	43610	41380	29530	23990	2000	92000	58
	13.22	51440	51440	51440	43100	26590	21600	2000	80980	58
	15.33	55910	49540	43610	41380	29500	23970	2000	92000	58
	18.49	50740	49540	43610	41380	29120	23660	2000	92000	58
	22.40	44070	37200	33370	31980	28970	27060	2000	92000	58
RR5200 A3 (A)	43.83	33920	26900	21850	17750	10950	8900	3500	92000	28
	49.58	38370	29330	23820	19350	11940	9700	3500	92000	28
	57.51	42840	32540	26430	21470	13250	10760	3500	92000	28
	67.04	47690	36230	29430	23900	14750	11980	3500	92000	28
	81.77	41060	38360	33820	27470	16950	13770	3500	92000	28
	99.08	44070	37200	33370	31420	19380	15750	3500	92000	28
	116.06	44070	37200	33370	30940	19090	15510	3500	92000	28
	147.20	43250	37200	33370	29640	18290	14860	3500	92000	28
	(B)									
	44.40	62150	57390	53360	43350	26750	21720	2500	92000	33
	50.22	62150	54150	51900	47250	29160	23680	2500	92000	33
	58.26	55910	49540	43610	41380	32350	26280	2500	92000	33
	67.92	55420	49540	43610	41380	34810	28270	2500	92000	33
	70.50	55910	49540	43610	41380	31150	25300	2500	92000	33
	83.08	55910	49540	43610	41380	29400	23880	2500	92000	33
	96.84	55420	49540	43610	41380	32730	26580	2500	92000	33
	118.12	41060	38360	36760	35230	31920	28270	2500	92000	33
	143.11	44070	37200	33370	31980	28970	27690	2500	92000	33
	(C)									
	45.08	62150	57390	55540	51470	31760	25800	2500	92000	34
	50.99	62150	54150	51900	49740	34620	28120	2500	92000	34
	58.31	62150	54150	51900	49740	35060	28480	2500	92000	34
	66.59	62150	57390	55540	51490	31970	25960	2500	92000	34
	75.33	62150	54150	51900	49740	34850	28300	2500	92000	34
	87.39	55910	49540	43610	41380	34810	28270	2500	92000	34
	101.87	55420	49540	43610	41380	34810	28270	2500	92000	34
	124.25	41060	38360	36760	35230	31920	28270	2500	92000	34
	150.55	44070	37200	33370	31980	28970	27690	2500	92000	34
RR5200 A4	149.01	62150	57390	50180	40760	25150	20430	3500	92000	23
	175.30	62150	57390	55540	45670	28180	22890	3500	92000	23
	198.31	62150	54150	51900	49740	30720	24950	3500	92000	23
	247.89	51610	48790	46760	44820	30380	24680	3500	92000	23
	290.38	51610	48790	46760	44820	30380	24680	3500	92000	23
	368.29	51610	48790	46760	44820	30380	24680	3500	92000	23
	427.24	55910	49540	43610	41380	33710	27380	3500	92000	23
	498.05	55420	49540	43610	41380	34810	28270	3500	92000	23
	577.73	55420	49540	43610	41380	34810	28270	3500	92000	23
	697.26	43140	40790	39090	37470	34580	28270	3500	92000	23
	850.45	41060	38360	36760	35230	31920	28270	3500	92000	23
	1030.40	44070	37200	33370	31980	28970	27690	3500	92000	23



RR5200

IT EN DE FR ES PT

RR5200 L.. .. i

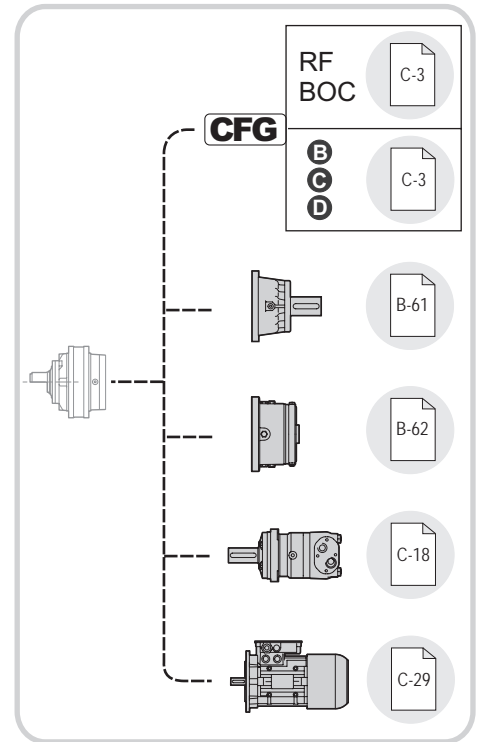
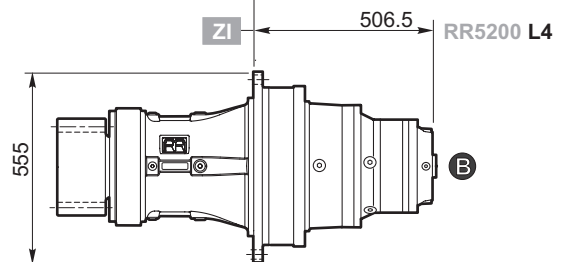
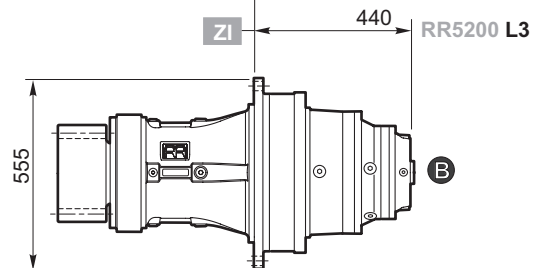
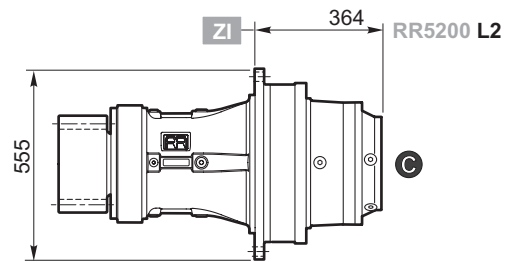
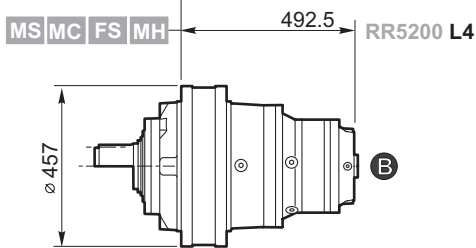
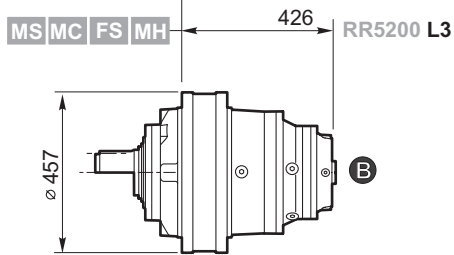
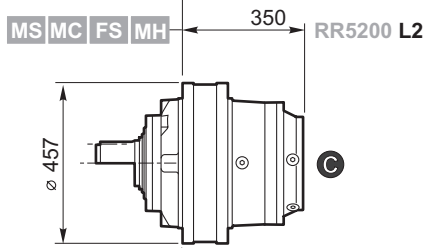
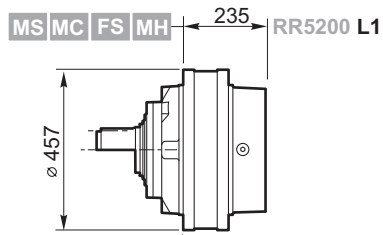

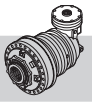

RR5200 A.. .. i

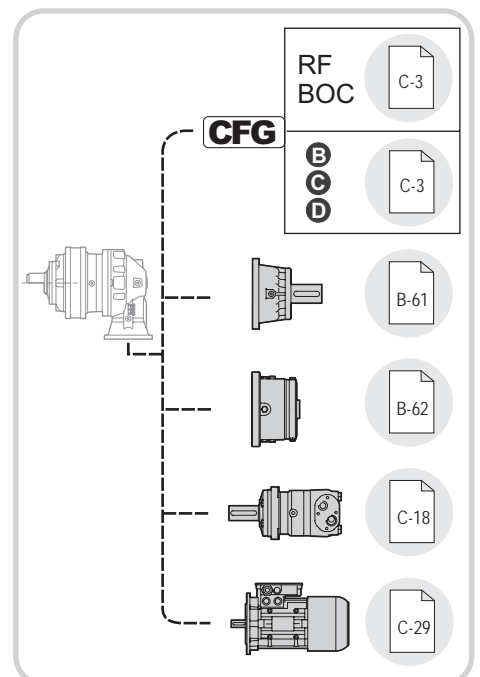
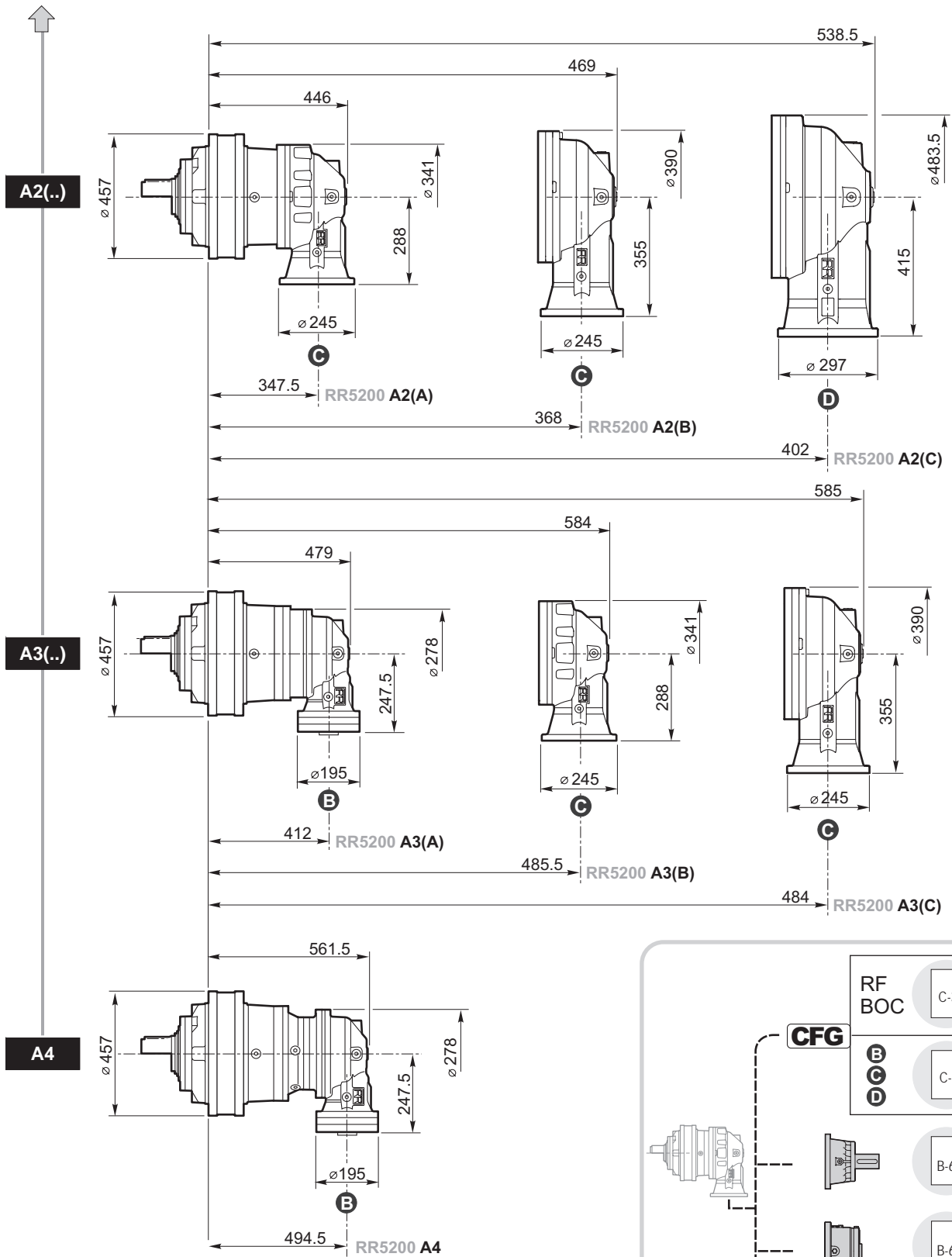

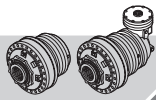

RR5200

IT EN DE FR ES PT

RR5200	L..	MS	i
RR5200	A..		i

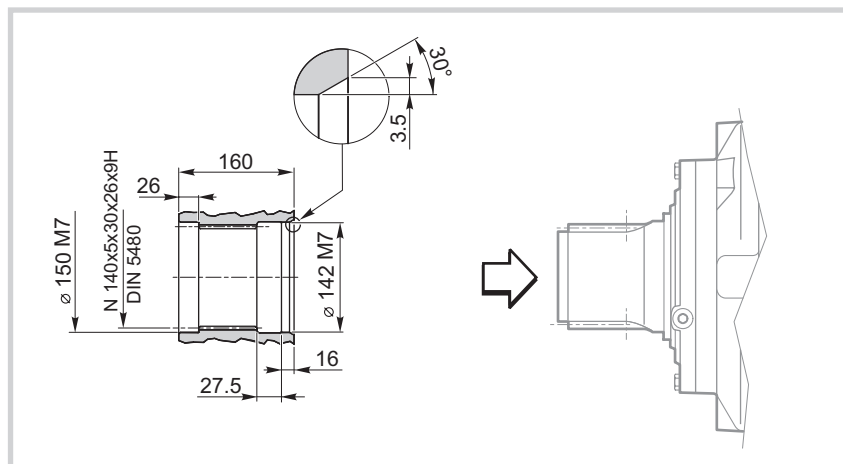
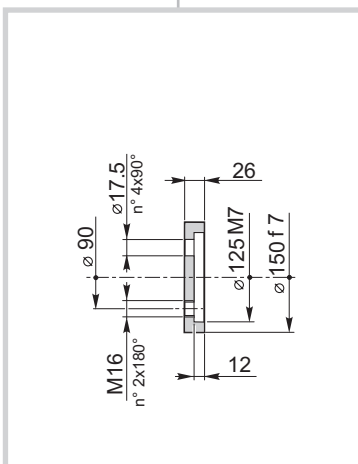
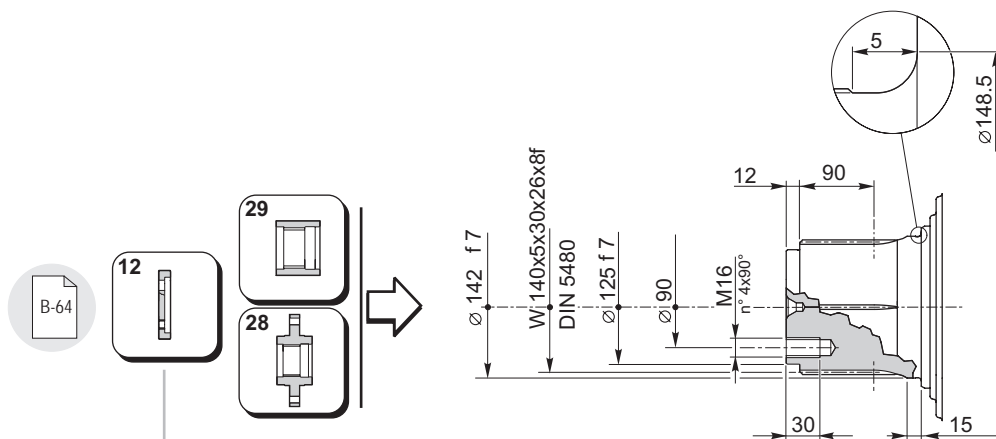
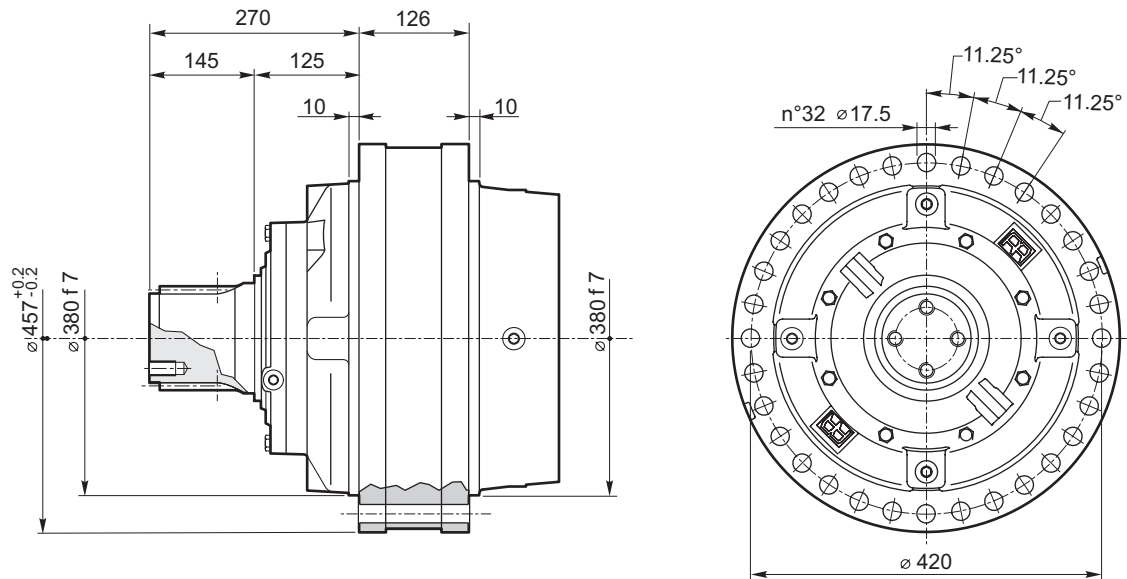

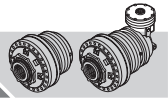

RR5200	L..	MC	i
RR5200	A..		i

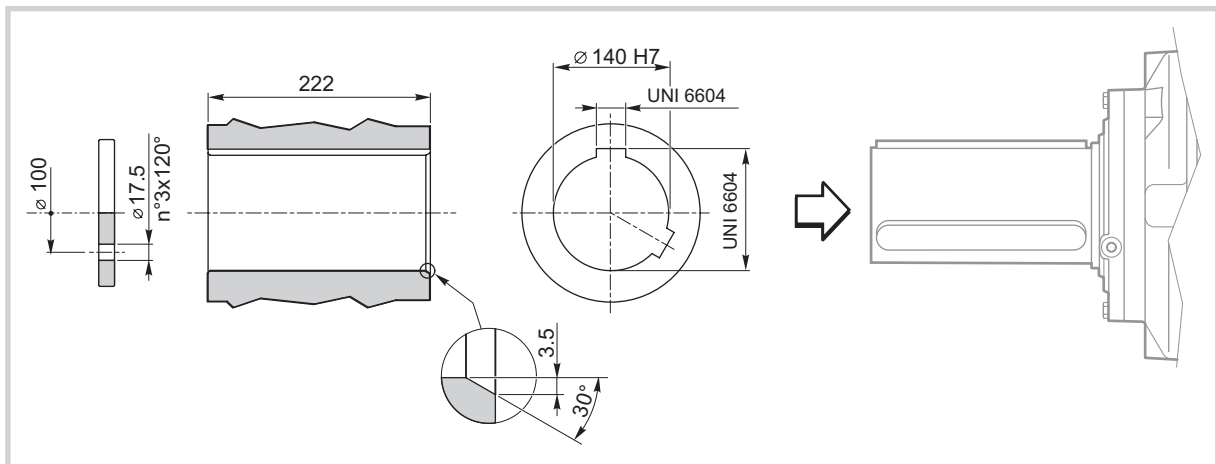
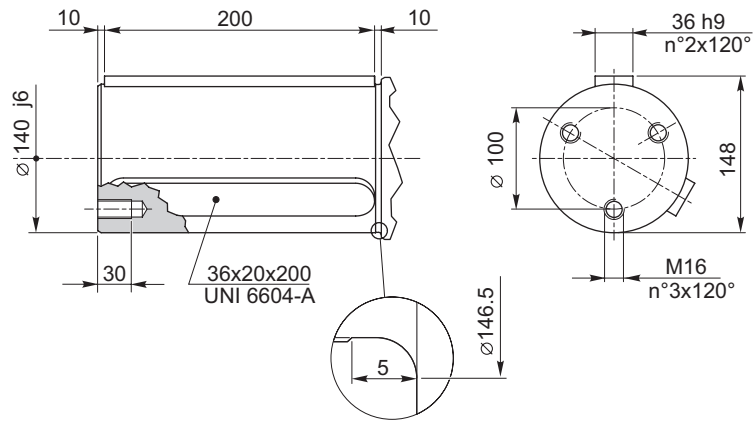
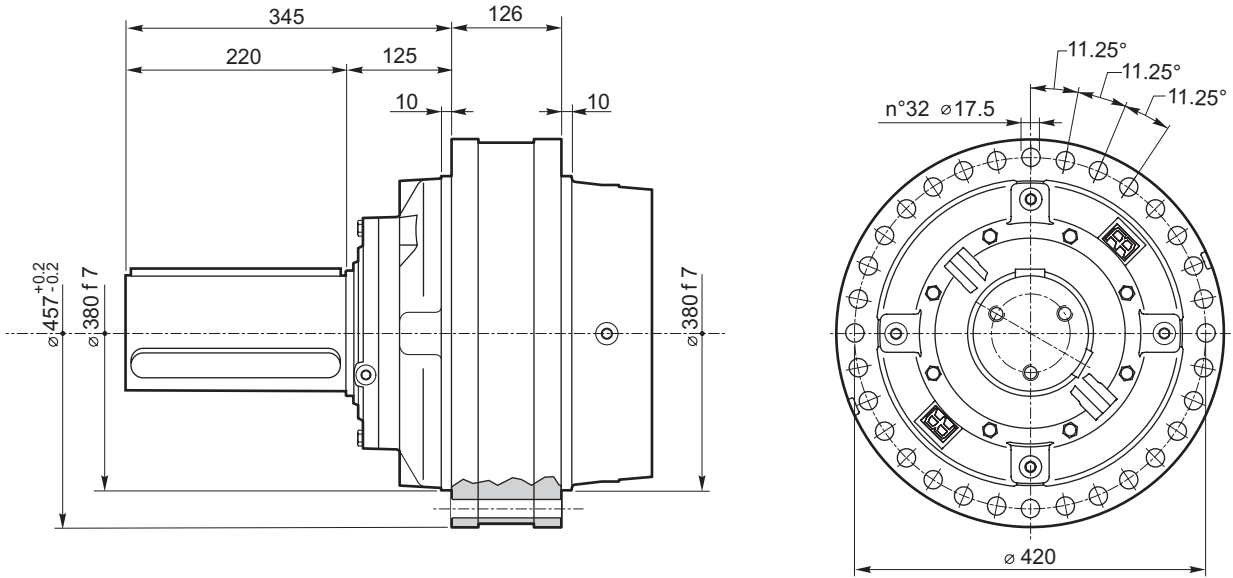

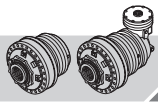

RR5200

IT EN DEFRES PT

RR5200	L..	FS	i
RR5200	A..		i

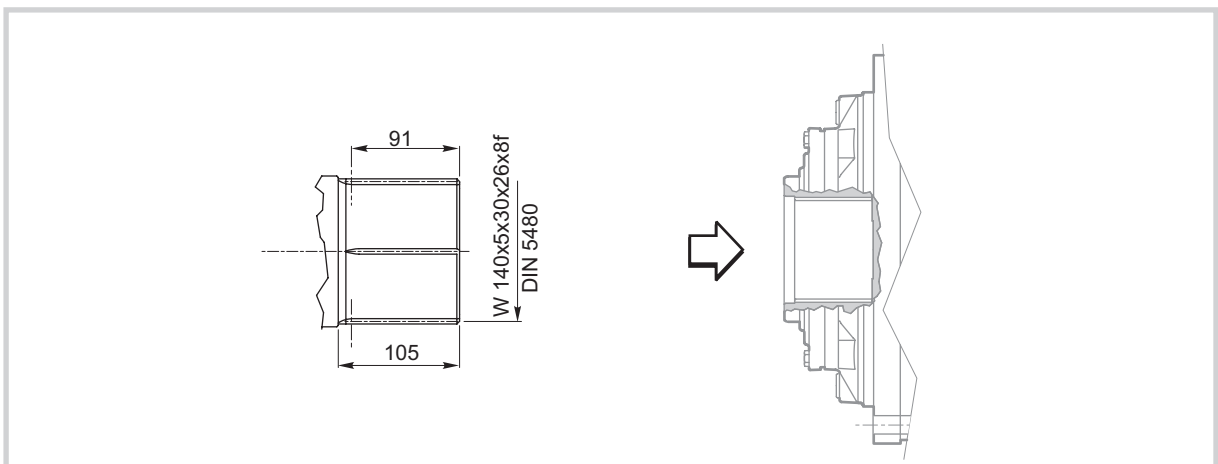
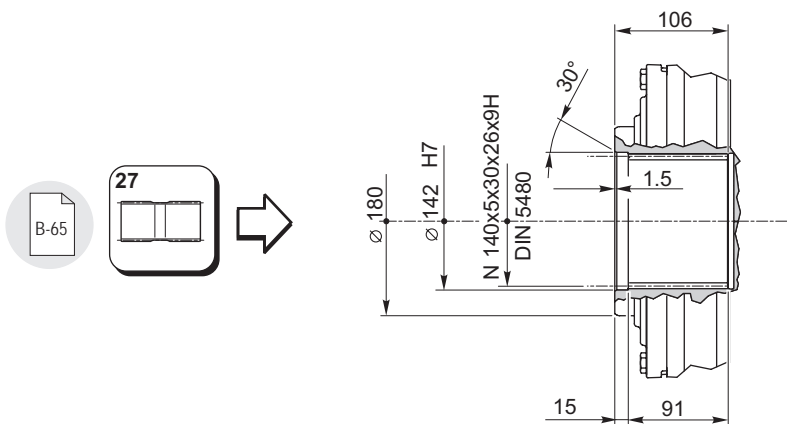
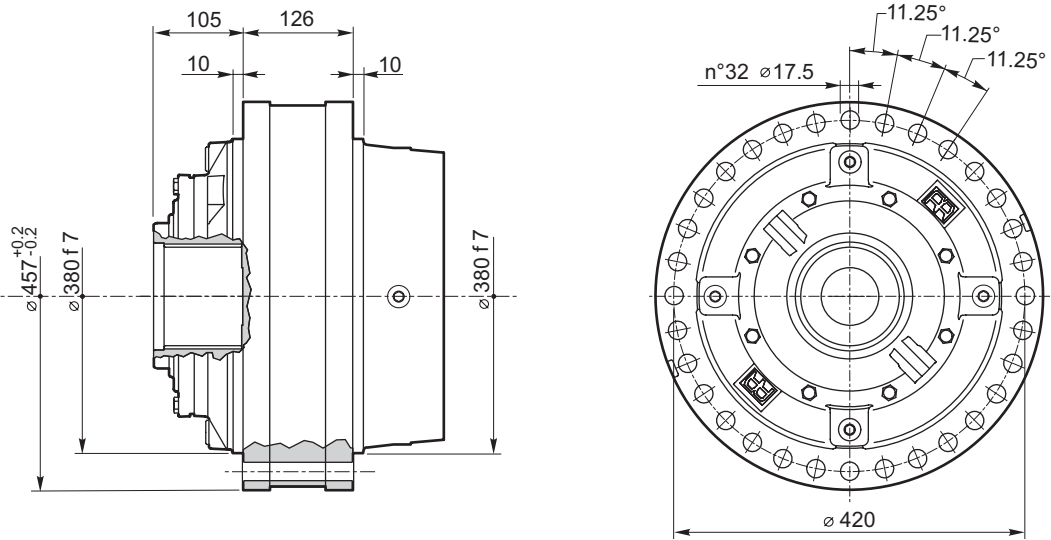

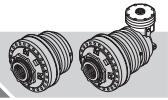

RR5200	L..	MH	i
RR5200	A..		i

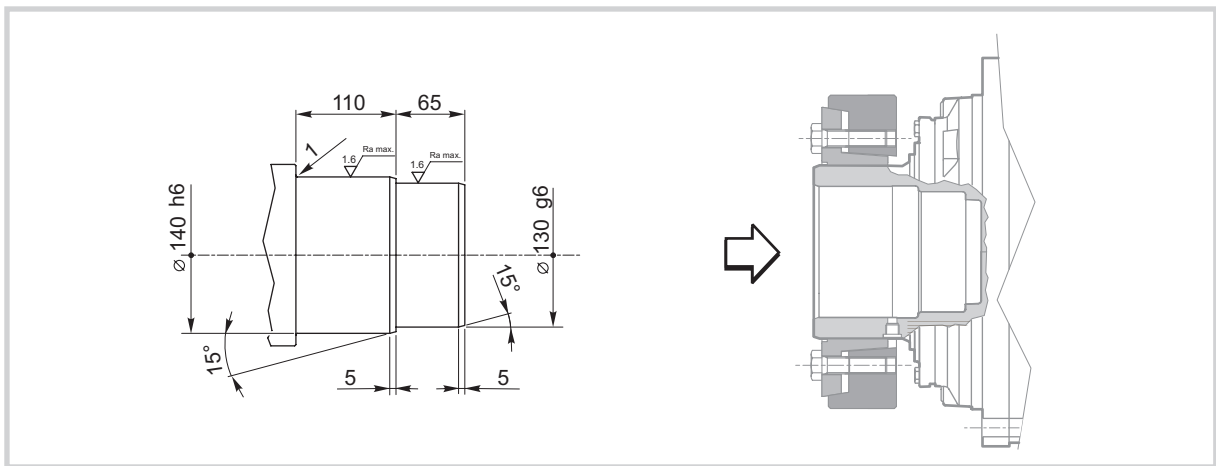
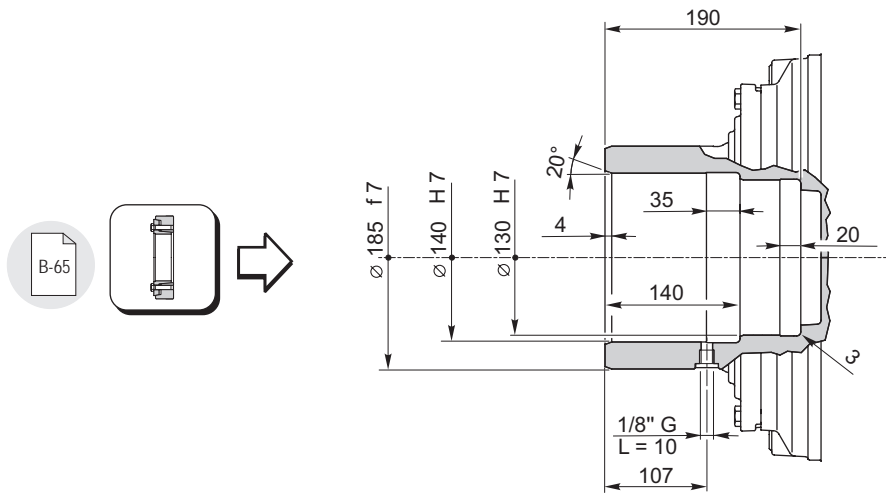
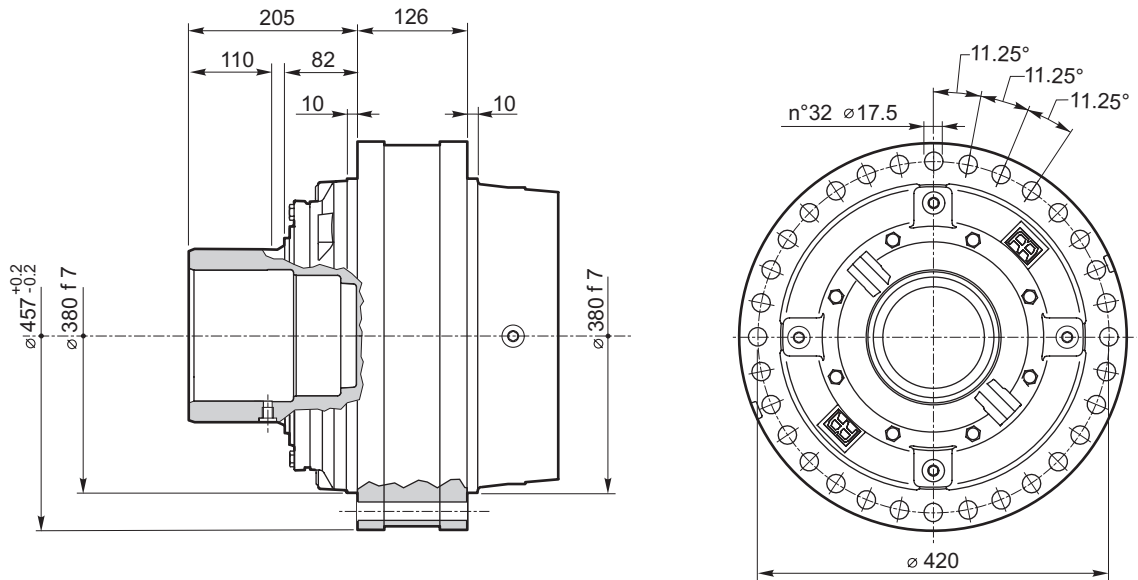



RR5200

IT EN DE FR ES PT

RR5200 L.. **ZI** i

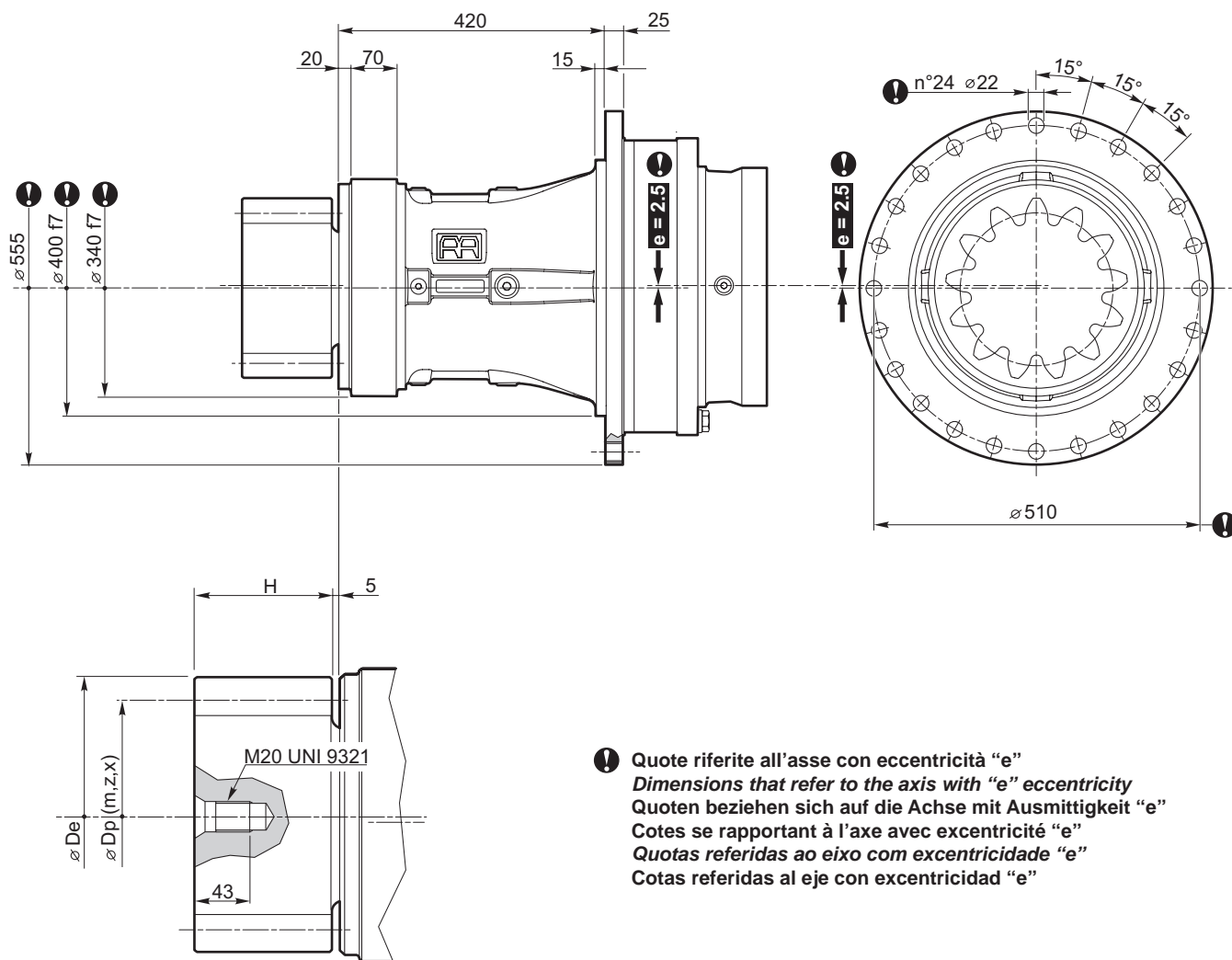

	m	z	x	H	Dp	De	code
	16	14	0.5	150	224	272	03-644
	18	14	0.5	150	252	306	03-643
	20	12	0.5	150	240	300	03-645

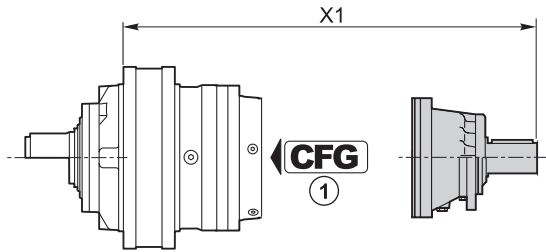
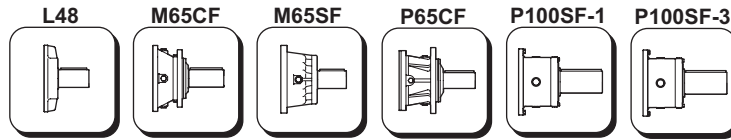
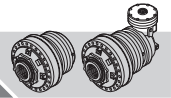

	CFG ①		code	X1
RR5200 L1	—	P100SF-3	154F3324	612
RR5200 L2	—	P65CF	154-2404	662
RR5200 L3	RF	M65SF	154B4249	610.5
	RF	M65CF	154-2407	633.5
	BOC	L48	154B3989	547.3
RR5200 L4	RF	M65SF	154B4249	677
	RF	M65CF	154-2407	700
	BOC	L48	154B3989	613.8

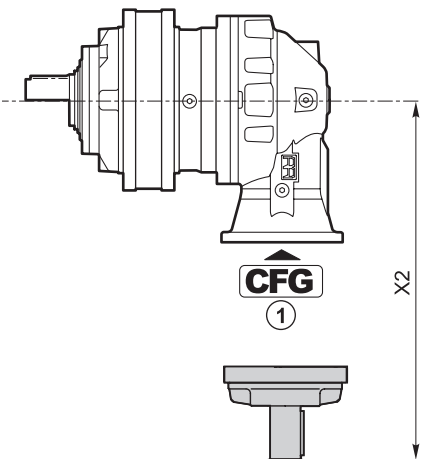

	CFG ①		code	X2
RR5200 A2(A)	—	P65CF	154-2404	600
RR5200 A2(B)	—	P65CF	154-2404	667
RR5200 A2(C)	—	P100SF-1	154F3322	791.5
RR5200 A3(A)	BOC	L48	154B3989	347.8
RR5200 A3(B)	—	P65CF	154-2404	600
RR5200 A3(C)	—	P65CF	154-2404	667
RR5200 A4	BOC	L48	154B3989	347.8

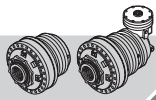

RR5200

IT EN DE FR ES PT

RF170-290



RF5/..

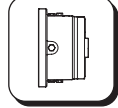

RFF5/..

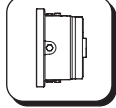

RF2/..

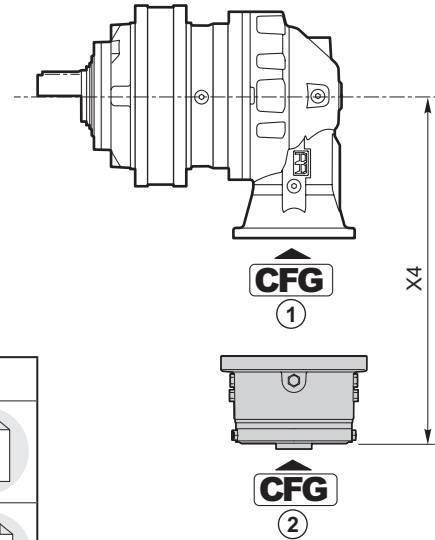
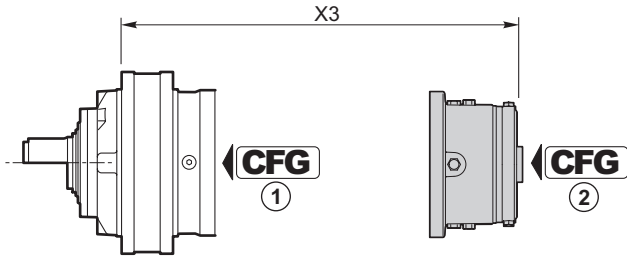
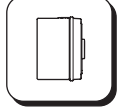

RF170-290	CFG ①	T _f [Nm]	CFG ②		
			C		
			code	X3	X4
RR5200 L2	RF	1700	154B9766M2	547	—
		2000	154B9767M2		
		2300	154B9768M2		
		2900	154B9769M2		
RR5200 A2(A)	—	1700	154B9766M3	—	485
		2000	154B9767M3		
		2300	154B9768M3		
RR5200 A2(B)	—	2900	154B9769M3	—	552
		1700	154B9766M3		
		2000	154B9767M3		
		2300	154B9768M3		
RR5200 A3(B)	—	2900	154B9769M3	—	485
		1700	154B9766M3		
		2000	154B9767M3		
		2300	154B9768M3		
RR5200 A3(C)	—	2900	154B9769M3	—	552
		1700	154B9766M3		
		2000	154B9767M3		
		2300	154B9768M3		

CFG	
RF BOC	C-3
B C D	C-3

RF5/..	CFG ①	T _f [Nm]	CFG ②						
			B			OMTS 12/24 z16	OMVS 10/20 z16		
			code	X3	X4	code	code	X3	X4
RR5200 L3	RF	210	154-2872	516.3	—	154-2879	154-2886	520	—
		290	154-2873			154-2880	154-2887		
		430	154-2874			154-2881	154-2888		
		650	154-2875			154-2882	154-2889		
		850	154-2876			154-2883	154-2890		
		1100	154-2877			154-2884	154-2891		
RR5200 L4	RF	1300	154-2878	154-2885	154-2892	586.5	—		
		210	154-2872	154-2879	154-2886				
		290	154-2873	154-2880	154-2887				
		430	154-2874	154-2881	154-2888				
		650	154-2875	154-2882	154-2889				
		850	154-2876	154-2883	154-2890				
1100	154-2877	154-2884	154-2891						
1300	154-2878	154-2885	154-2892						

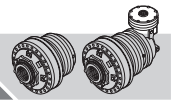

RFF5/..	CFG ①	T _f [Nm]	CFG ②						
			B			OMTS 12/24 z16	OMVS 10/20 z16		
			code	X3	X4	code	code	X3	X4
RR5200 A3(A)	RF	210	154-2893	—	316.6	154-5338	154-5345	—	320.5
		290	154-2894			154-5339	154-5346		
		430	154-2895			154-5340	154-5347		
		650	154-2896			154-5341	154-5348		
		850	154-2897			154-5342	154-5349		
		1100	154-2898			154-5343	154-5350		
		1300	154-2899			154-5344	154-5351		
RR5200 A4	RF	210	154-2893	—	316.6	154-5338	154-5345	—	320.5
		290	154-2894			154-5339	154-5346		
		430	154-2895			154-5340	154-5347		
		650	154-2896			154-5341	154-5348		
		850	154-2897			154-5342	154-5349		
		1100	154-2898			154-5343	154-5350		
		1300	154-2899			154-5344	154-5351		

CFG	
RF	
B C D	

RF2/..	CFG ①	T _f [Nm]	CFG ②								
			B			OMP/OMR SAE A 2B Ø 25	OMP/OMR SAE A 2B 1" 6B	OMP/OMR SAE A 4B Ø 25	OMP/OMR SAE A 4B 1" 6B		
			code	X3	X4	code	code	code	code	X3	X4
RR5200 L3	RF	70	154B9195	488.8	—	154B9195M10		154B9195M16	154B9195M17	478.8	—
		140	154B9196			154B9196M10		154B9196M16	154B9196M17		
		210	154B9197			154B9197M10		154B9197M16	154B9197M17		
		320	154B9198			154B9198M10		154B9198M16	154B9198M17		
		430	154B9199			154B9199M10		154B9199M16	154B9199M17		
		600	154B9200			154B9200M10		154B9200M16	154B9200M17		
RR5200 L4	RF	70	154-2345	555.3	—	154-2345M10	154-2345M11	154-2345M16	154-2345M17	545.3	—
		140	154-2346			154-2346M10	154-2346M11	154-2346M16	154-2346M17		
		210	154-2347			154-2347M10	154-2347M11	154-2347M16	154-2347M17		
		320	154-2348			154-2348M10	154-2348M11	154-2348M16	154-2348M17		
		430	154-2349			154-2349M10	154-2349M11	154-2349M16	154-2349M17		
		600	154B9186			154B9186M10	154B9186M11	154B9186M16	154B9186M17		
RR5200 A3(A)	RF	70	154F2991	—	285.3						
		140	154F1890								
		210	154F2961								
		320	154B3591								
		430	154B3592								
		600	154F2992								
RR5200 A4	RF	70	154F2991	—	285.3						
		140	154F1890								
		210	154F2961								
		320	154B3591								
		430	154B3592								
		600	154F2992								

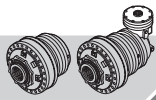

RR5200

IT EN DE FR ES PT

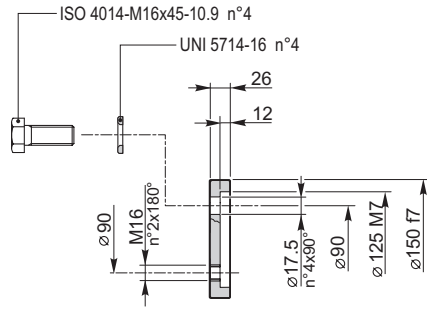
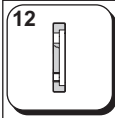

154F6032

Materiale / Material / Material / Matériau / Material / Material:
Acciaio / Steel / Stahl / Acier / Acero / Aço
EN 10083-1-42CrMo4+QT (1.7225)

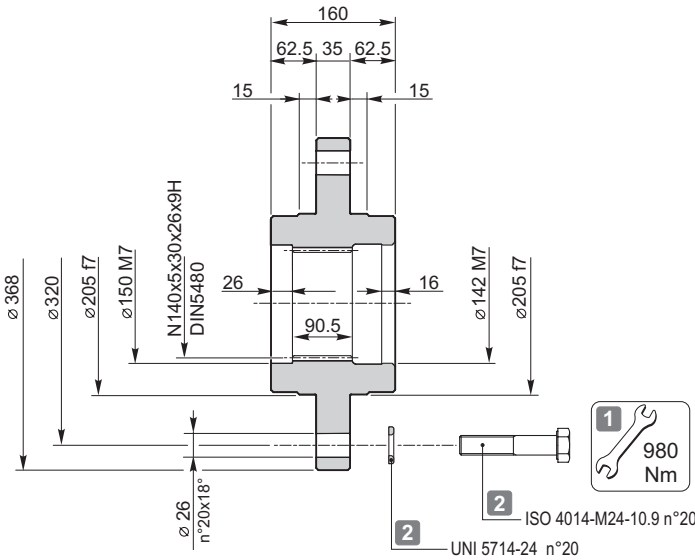
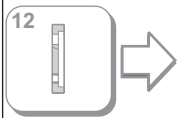
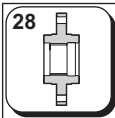

154F6050

Materiale / Material / Material / Matériau / Material / Material:
Acciaio / Steel / Stahl / Acier / Acero / Aço
EN 10083-1-C40 (1.1186)

Trattamento termico:
 Tempra ad induzione secondo UNI 10932 su scanalato interno

Heat treatment:
 Induction hardening according to UNI 10932 on internal spline

Wärmebehandlung:
 Induktionshärtung nach UNI 10932 an interner Nut

Traitement thermique:
 Trempe par induction conformément à la norme UNI 10932 sur cannelé interne

Tratamiento térmico:
 Temple por inducción según UNI 10932 en acanalado interno

Tratamento térmico:
 Tempra por indução segundo UNI 10932 sobre ranhuras internas

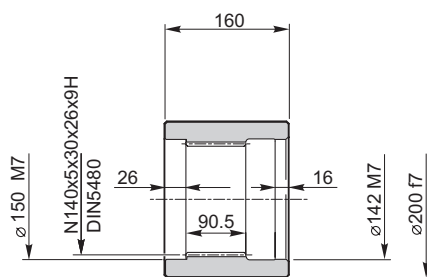
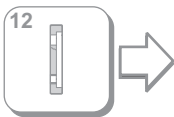

154F6058

Materiale / Material / Material / Matériau / Material / Material:
Acciaio / Steel / Stahl / Acier / Acero / Aço
EN 10083-1-42CrMo4+QT (1.7225)

Trattamento termico:
 Tempra ad induzione secondo UNI 10932 su scanalato interno

Heat treatment:
 Induction hardening according to UNI 10932 on internal spline

Wärmebehandlung:
 Induktionshärtung nach UNI 10932 an interner Nut

Traitement thermique:
 Trempe par induction conformément à la norme UNI 10932 sur cannelé interne

Tratamiento térmico:
 Temple por inducción según UNI 10932 en acanalado interno

Tratamento térmico:
 Tempra por indução segundo UNI 10932 sobre ranhuras internas

1 Coefficiente d'attrito medio considerato: 0.14
 Average friction coefficient considered: 0.14
 Durchschnittlicher berücksichtigter Reibungskoeffizient: 0.14
 Coefficient de frottement moyen considéré: 0.14
 Coeficiente medio de fricción considerado: 0.14
 Coeficiente de atrito médio considerado: 0.14

2 Componenti non forniti da Reggiana Riduttori
 Components not supplied by Reggiana Riduttori
 Nicht von Reggiana Riduttori gelieferte Komponenten
 Parties pas fournies par Reggiana Riduttori
 Componentes no suministrados por Reggiana Riduttori
 Componentes não fornecidos por Reggiana Riduttori

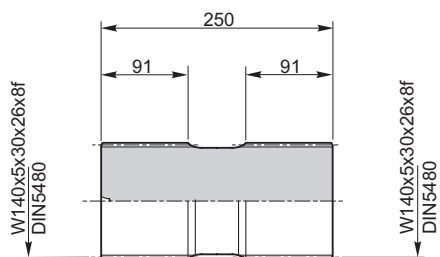
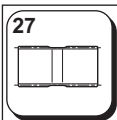
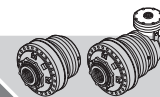

Materiale / Material / Material / Matériau / Material / Material:
 Acciaio / Steel / Stahl / Acier / Acero / Aço
 EN 10083-1-42CrMo4+QT (1.7225)

154F6038

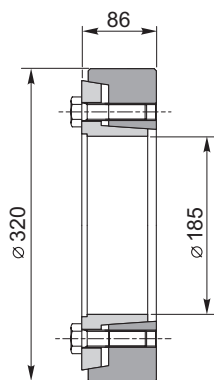
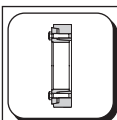

C-32

154F6066

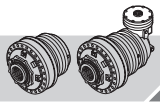

RR5200

IT EN DE FR ES PT

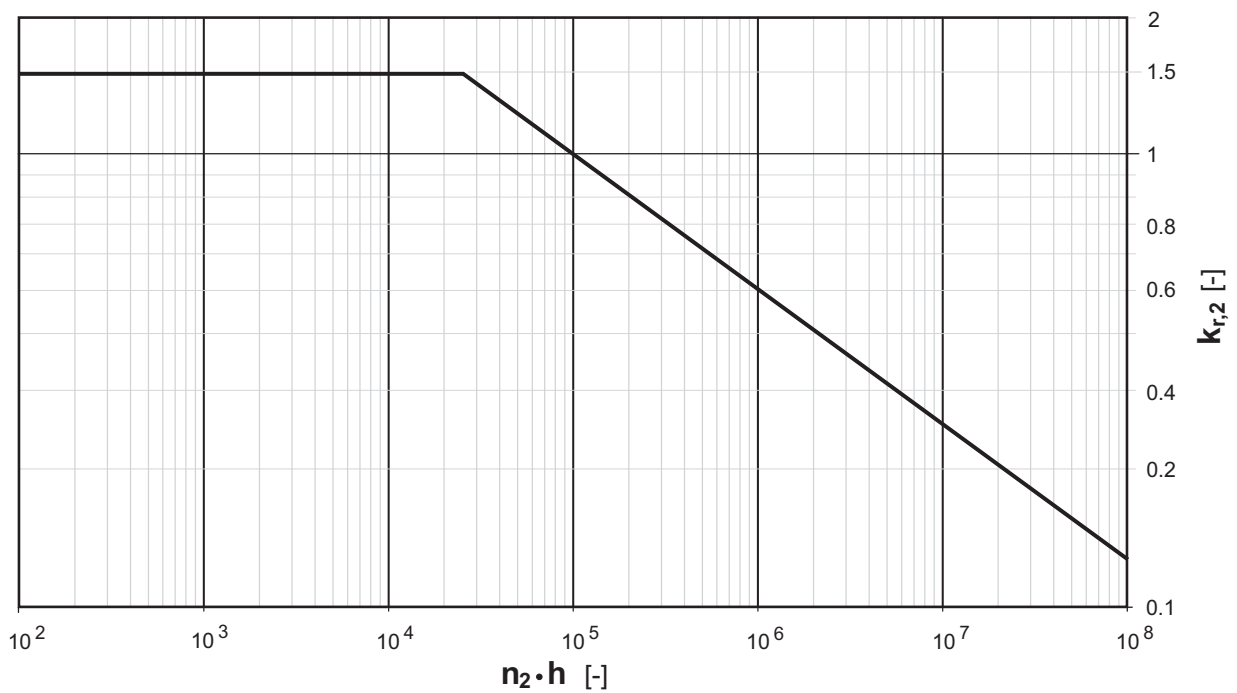
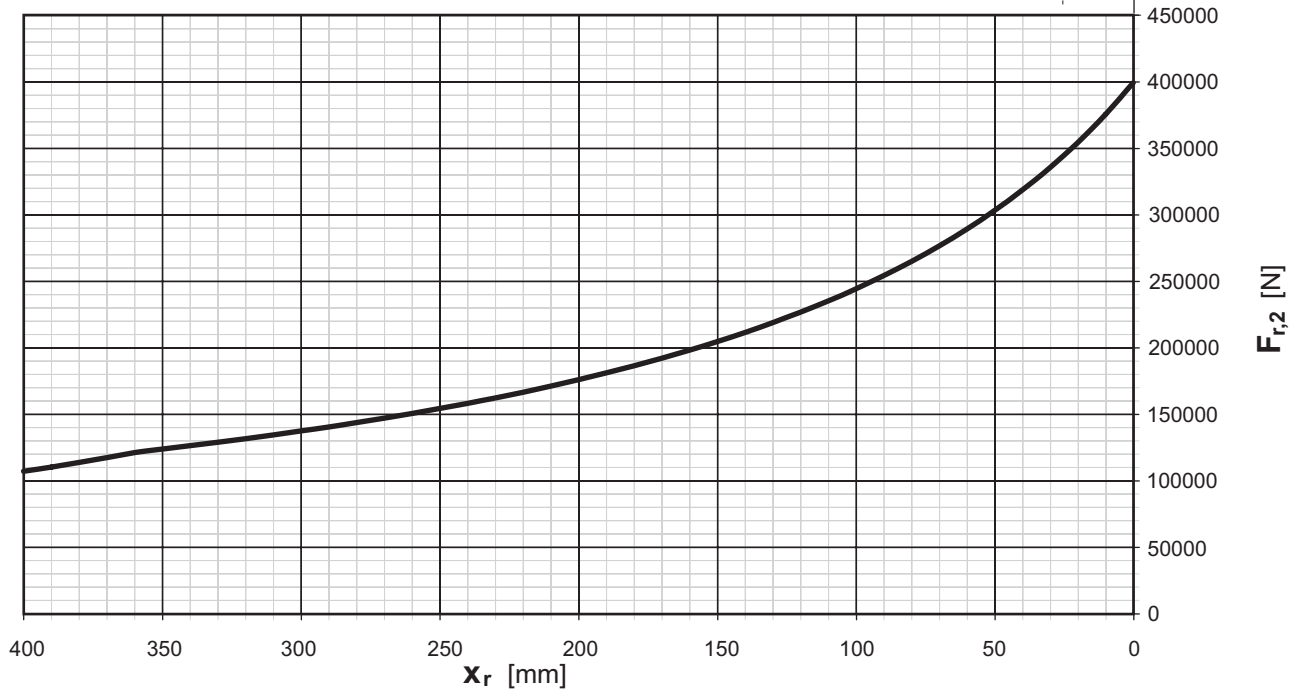
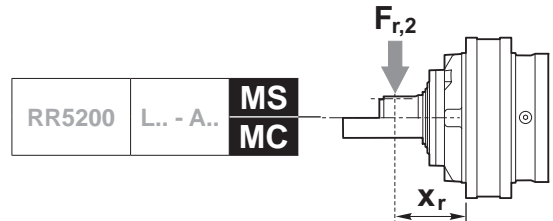

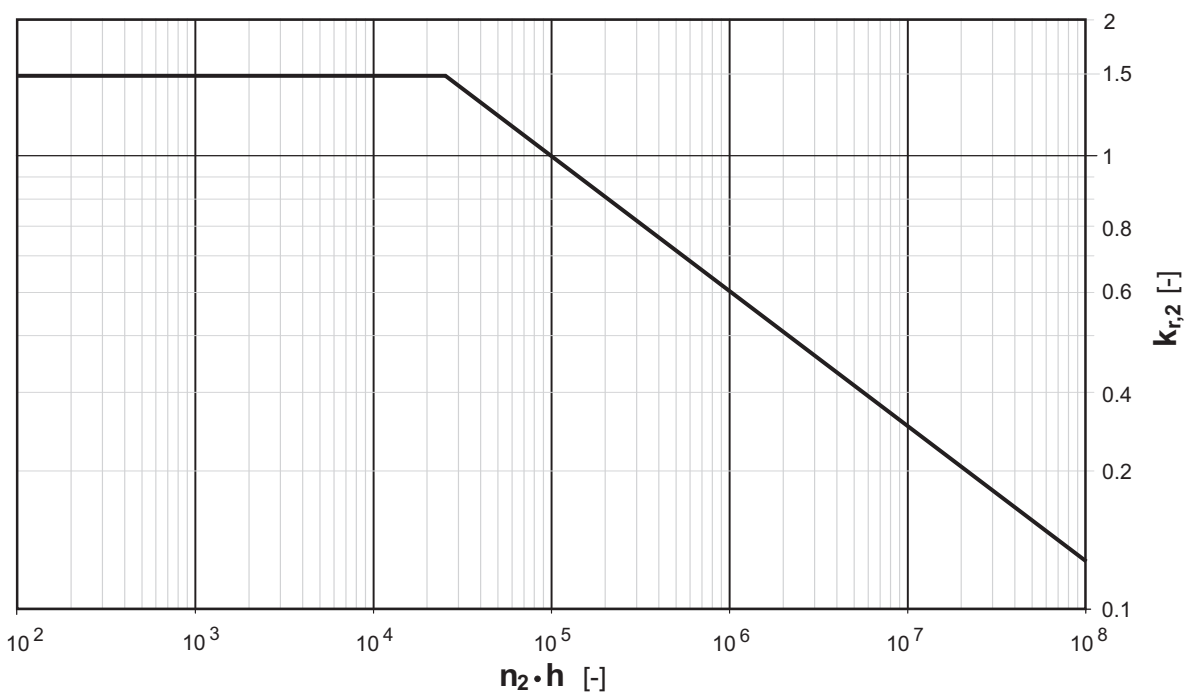
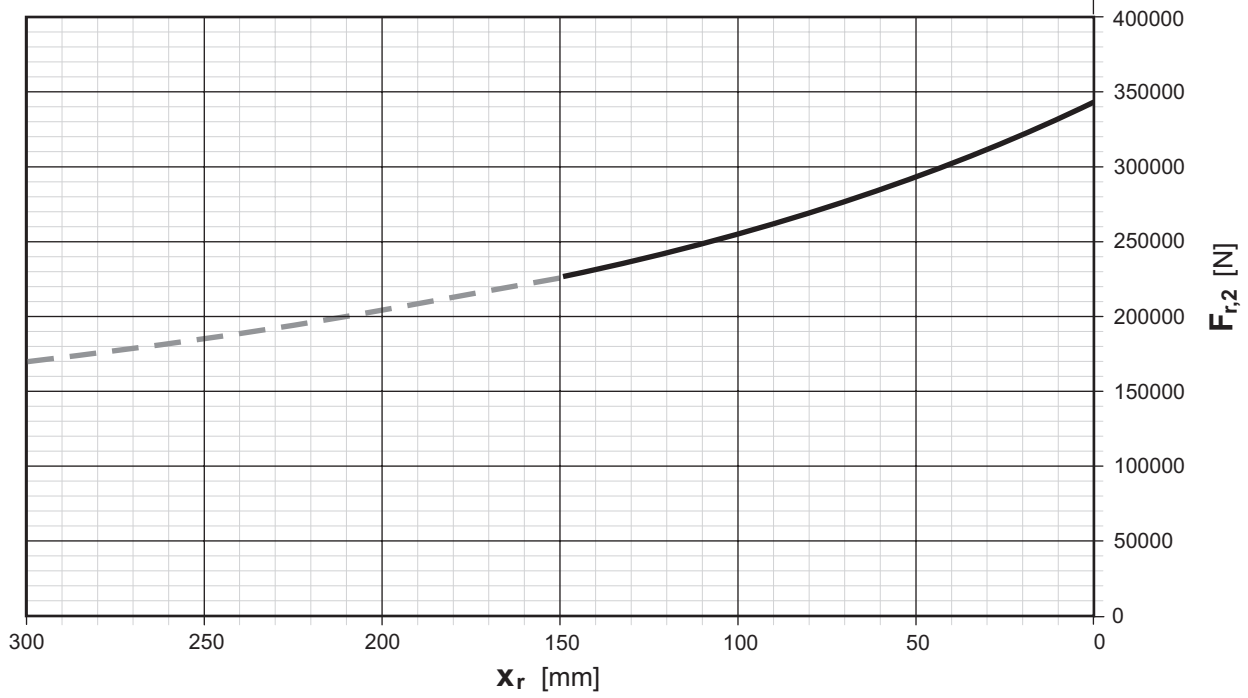
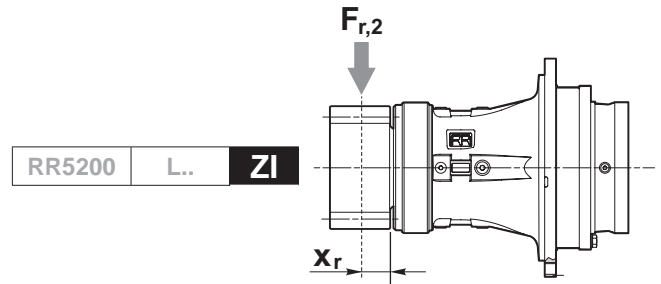



RR6500

IT EN DE FR ES PT

RR6500 L.. .. **i**



i	T ₂ [Nm]						n _{1max} [min ⁻¹]	T _{2max} [Nm]	P _t [kW]	
	n ₂ x h									
1/...	10000 (10 ⁴)	25000 (2.5 · 10 ⁴)	50000 (5 · 10 ⁴)	100000 (10 ⁵)	500000 (5 · 10 ⁵)	1000000 (10 ⁶)				
RR6500 L1	4.17	81040	74890	72940	67640	42750	34720	1000	125000	73
	4.84	73730	67450	60460	57370	42020	34130	1000	125000	73
	5.87	62830	53090	47640	45650	41170	33440	1000	125000	73
RR6500 L2	16.70	81040	74890	72940	67640	42750	34720	2000	125000	44
	19.64	81040	74890	72940	67640	42750	34720	2000	125000	44
	22.79	73730	67450	60460	57370	42020	34130	2000	125000	44
	28.31	70340	66490	60460	57370	42020	34130	2000	125000	44
	34.30	62830	53090	47640	45650	41170	33440	2000	125000	44
RR6500 L3	65.50	81040	74890	72940	67640	42750	34720	3000	125000	32
	71.86	81040	74890	72940	67640	42750	34720	3000	125000	32
	77.06	81040	74890	72940	67640	42750	34720	3000	125000	32
	84.55	81040	74890	72940	67640	42750	34720	3000	125000	32
	91.34	81040	74890	72940	67640	42750	34720	3000	125000	32
	107.45	81040	74890	72940	67640	42750	34720	3000	125000	32
	126.27	75440	71330	68360	65520	42750	34720	3000	125000	32
	154.86	70340	66490	60460	57370	42020	34130	3000	125000	32
	181.98	70340	66490	60460	57370	42020	34130	3000	125000	32
	223.89	69790	65980	60460	57370	42020	34130	3000	125000	32
	271.26	62830	53090	47640	45650	41170	33440	3000	125000	32
	294.96	62830	53090	47640	45650	41170	33440	3000	125000	32
	RR6500 L4	222.69	81040	74890	72940	67640	42750	34720	3500	125000
261.99		81040	74890	72940	67640	42750	34720	3500	125000	25
310.54		81040	74890	72940	67640	42750	34720	3500	125000	25
365.34		81040	74890	72940	67640	42750	34720	3500	125000	25
416.81		81040	74890	72940	67640	42750	34720	3500	125000	25
456.68		81040	74890	72940	67640	42750	34720	3500	125000	25
529.74		81040	74890	72940	67640	42750	34720	3500	125000	25
623.23		81040	74890	72940	67640	42750	34720	3500	125000	25
752.17		81040	74890	72940	67640	42750	34720	3500	125000	25
883.89		75440	71330	68360	65520	42750	34720	3500	125000	25
1025.39		73730	67450	60460	57370	42020	34130	3500	125000	25
1119.44		69790	65980	60460	57370	42020	34130	3500	125000	25
1298.55		69790	65980	60460	57370	42020	34130	3500	125000	25
1567.22		69790	65980	60460	57370	42020	34130	3500	125000	25
1898.83		62830	53090	47640	45650	41170	33440	3500	125000	25
2064.71		62830	53090	47640	45650	41170	33440	3500	125000	25

RR6500 A.. .. **i**

i	T ₂ [Nm]						n _{1max} [min ⁻¹]	T _{2max} [Nm]	P _t [kW]	
	n ₂ x h									
	10000 (10 ⁴)	25000 (2.5 · 10 ⁴)	50000 (5 · 10 ⁴)	100000 (10 ⁵)	500000 (5 · 10 ⁵)	1000000 (10 ⁶)				
RR6500 A2	10.27	66830	65380	53100	43130	26620	21620	2000	81010	64
	11.92	73730	67450	58920	47860	29530	23990	2000	93950	64
	14.44	62830	53090	47640	45650	33780	27440	2000	113820	64
	15.33	59680	59680	58870	47820	29500	23970	2000	93960	64
	18.58	62830	53090	47640	45650	33750	27410	2000	113860	64
	22.40	61480	53090	47640	45650	33310	27060	2000	113840	64
RR6500 A3 (A)	45.53	81040	66870	54320	44120	27220	22110	2500	125000	39
	53.57	81040	74890	60860	49440	30500	24780	2500	125000	39
	62.14	73730	67450	60460	54850	33850	27490	2500	125000	39
	77.20	70340	66490	60460	57370	39400	32000	2500	125000	39
	93.42	70340	66490	60460	57370	37930	30810	2500	125000	39
	110.09	70340	66490	60460	57370	35800	29080	2500	125000	39
	133.38	62830	53090	47640	45650	40950	33260	2500	125000	39
(B)	46.23	81040	74890	64500	52390	32330	26260	2500	125000	42
	54.39	81040	74890	72270	58700	36220	29420	2500	125000	42
	63.10	73730	67450	60460	57370	40190	32640	2500	125000	42
	72.16	73730	67450	60460	57370	40700	33060	2500	125000	42
	78.39	70340	66490	60460	57370	42020	34130	2500	125000	42
	89.64	70340	66490	60460	57370	42020	34130	2500	125000	42
	93.22	73730	67450	60460	57370	40450	32860	2500	125000	42
	115.80	70340	66490	60460	57370	42020	34130	2500	125000	42
	140.31	62830	53090	47640	45650	41170	33440	2500	125000	42
(C)	41.10	81040	74890	72940	67640	42750	34720	2000	125000	50
	48.35	81040	74890	72940	67640	42750	34720	2000	125000	50
	52.87	81040	74890	72940	67640	42750	34720	2000	125000	50
	62.20	81040	74890	72940	67640	42750	34720	2000	125000	50
	75.00	81040	74890	72940	67640	42750	34720	2000	125000	50
	89.64	70340	66490	60460	57370	42020	34130	2000	125000	50
	108.08	70340	66490	60460	57370	42020	34130	2000	125000	50
	130.95	62830	53090	47640	45650	41170	33440	2000	125000	50
RR6500 A4	176.34	81040	69510	56460	45860	28300	22980	3500	125000	29
	207.46	81040	74890	63260	51380	31710	25750	3500	125000	29
	245.90	81040	74890	71260	57880	35710	29010	3500	125000	29
	289.30	81040	74890	72940	64850	40020	32500	3500	125000	29
	339.96	75440	71330	68360	65520	42750	34720	3500	125000	29
	398.24	75440	71330	68360	65520	42750	34720	3500	125000	29
	416.93	70340	66490	60460	57370	42020	34130	3500	125000	29
	505.08	75440	71330	68360	65520	42270	34330	3500	125000	29
	573.93	70340	66490	60460	57370	42020	34130	3500	125000	29
	602.78	69790	65980	60460	57370	42020	34130	3500	125000	29
	619.44	70340	66490	60460	57370	42020	34130	3500	125000	29
	727.91	70340	66490	60460	57370	42020	34130	3500	125000	29
	895.55	69790	65980	60460	57370	42020	34130	3500	125000	29
	1085.05	62830	53090	47640	45650	41170	33440	3500	125000	29
	1179.83	62830	53090	47640	45650	41170	33440	3500	125000	29



RR6500

IT EN DE FR ES PT

RR6500 L.. .. i



MS MC FS MH 262.5 RR6500 L1

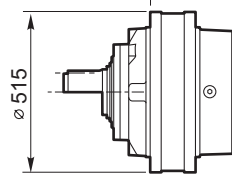

MS MC FS MH 427.5 RR6500 L2

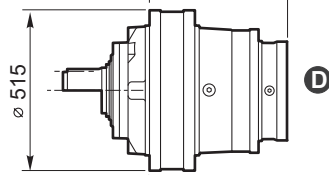

MS MC FS MH 520.5 RR6500 L3

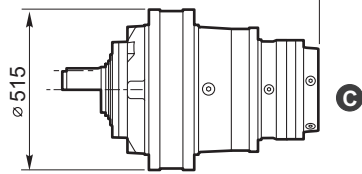

ZI 520.5 RR6500 L3

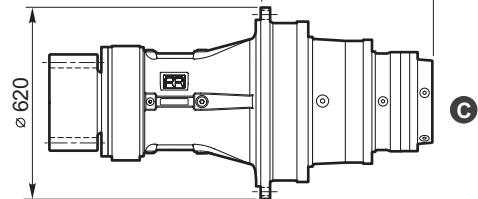

MS MC FS MH 588.5 RR6500 L4

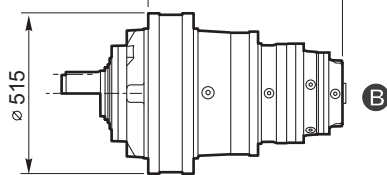

ZI 588.5 RR6500 L4

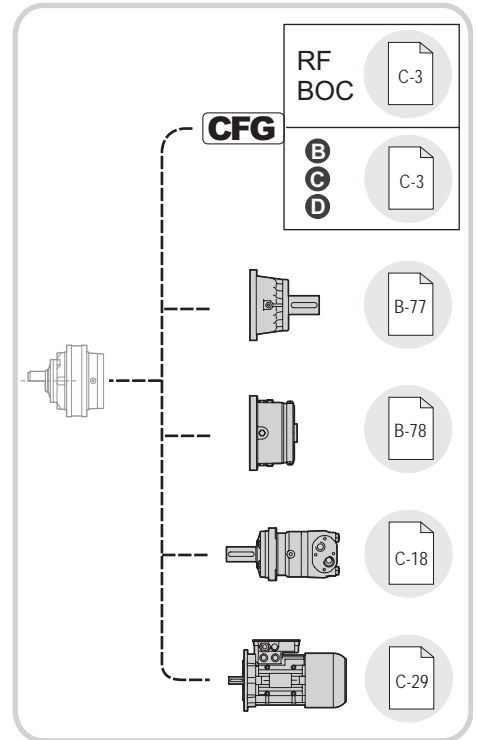
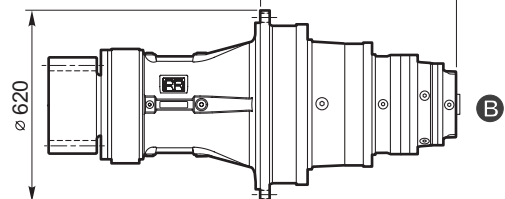

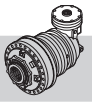

RR6500 A.. .. i

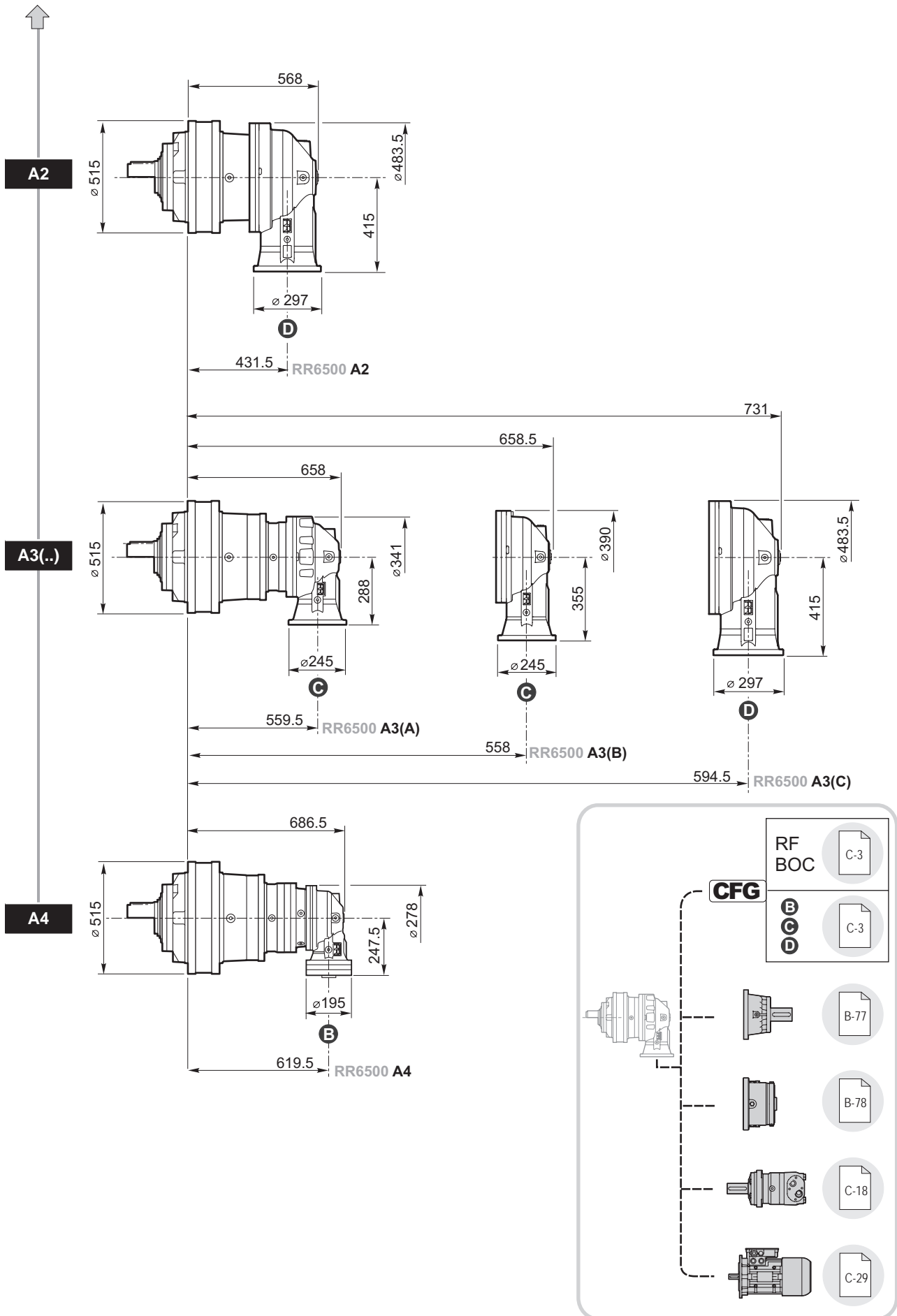

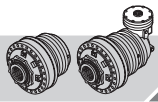

RR6500

IT EN DEFRES PT

RR6500	L..	MS	i
RR6500	A..		i

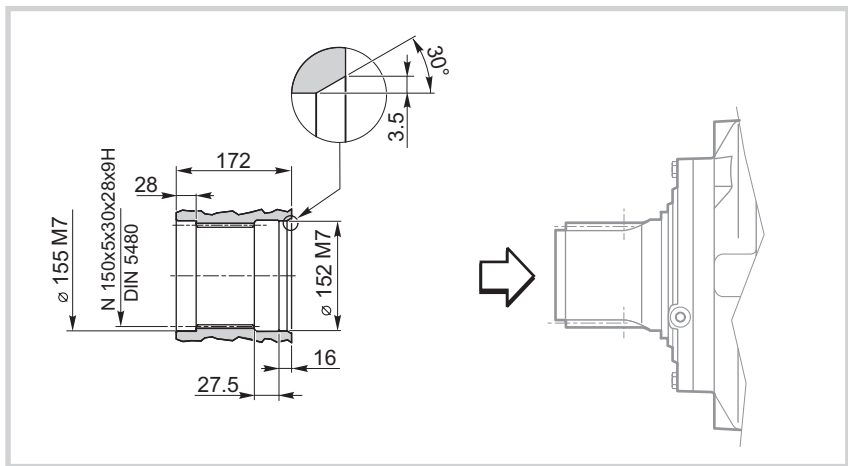
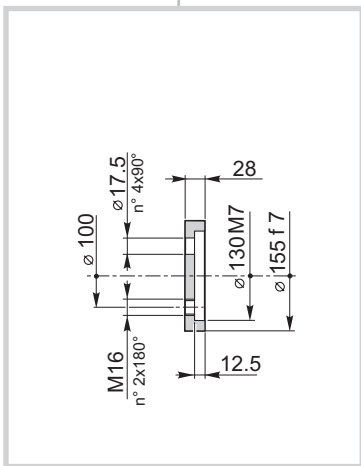
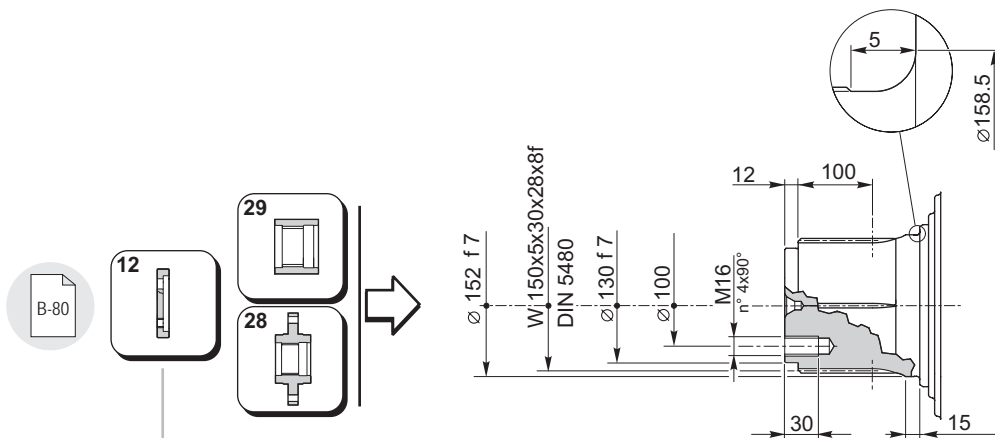
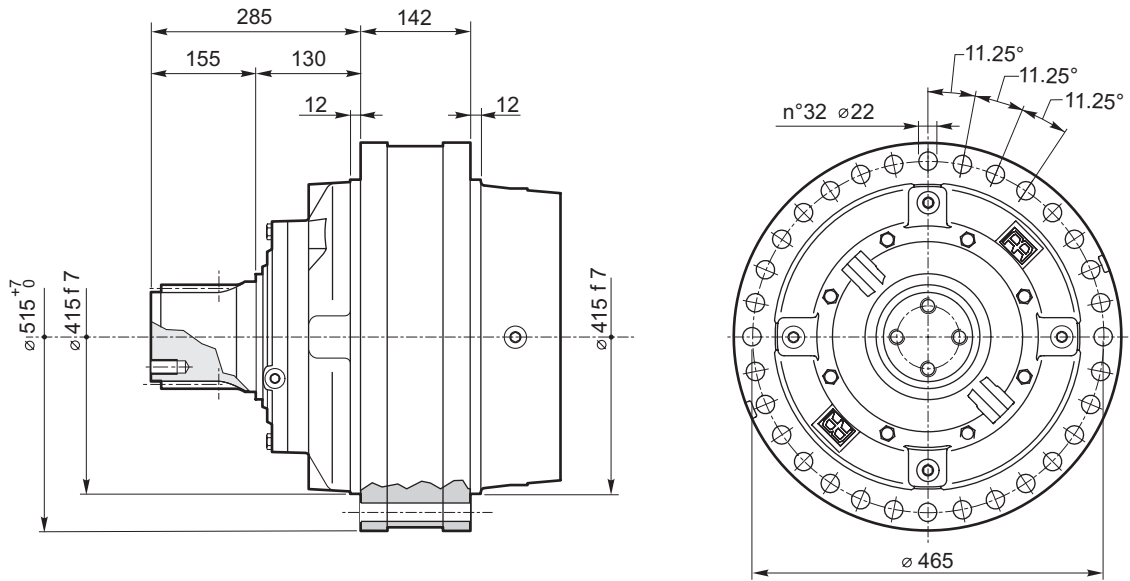

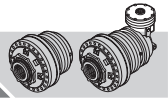

RR6500	L..	MC	i
RR6500	A..		i

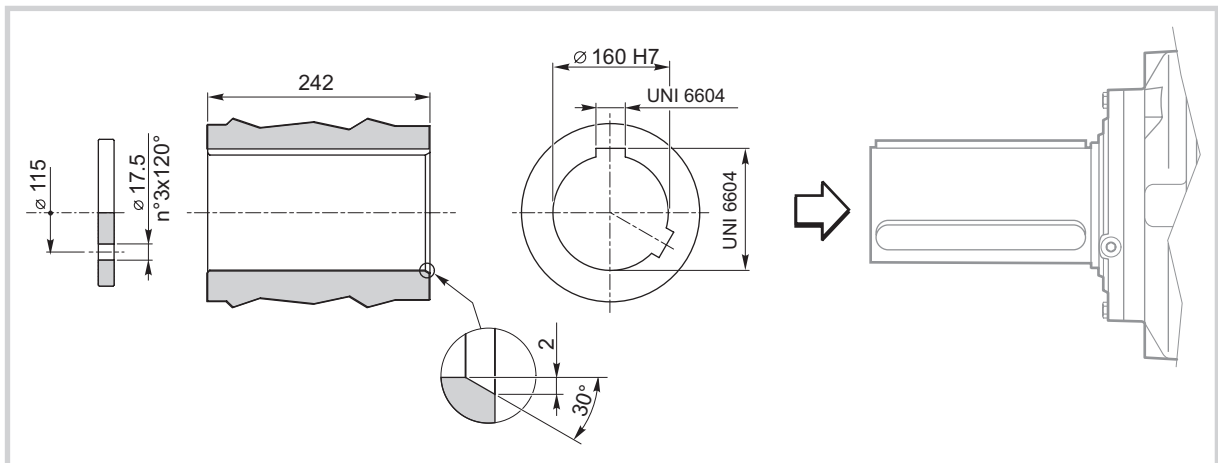
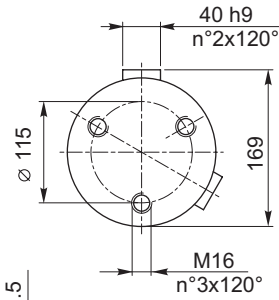
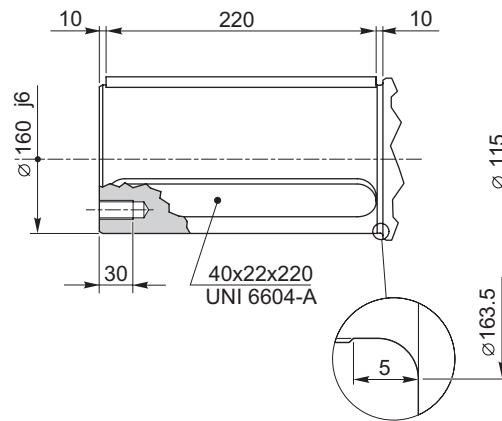
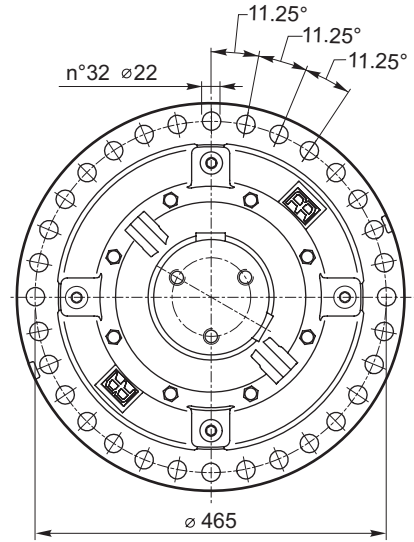
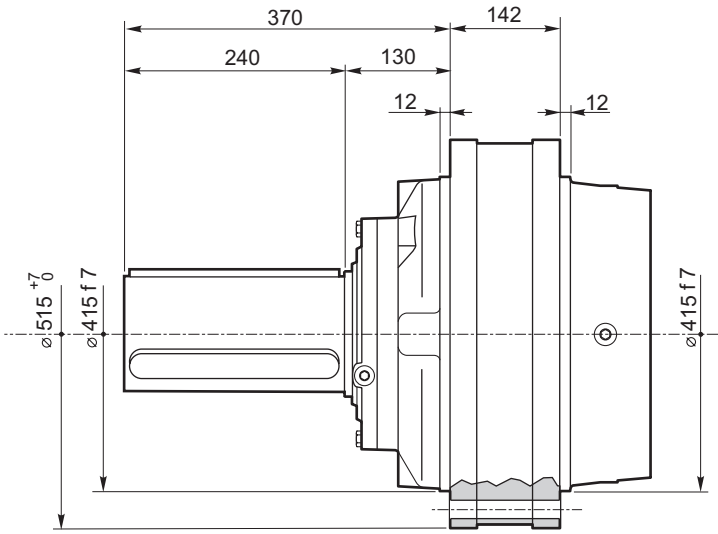

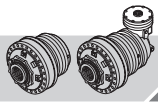

RR6500

IT EN DE FR ES PT

RR6500	L..	FS	i
RR6500	A..		i

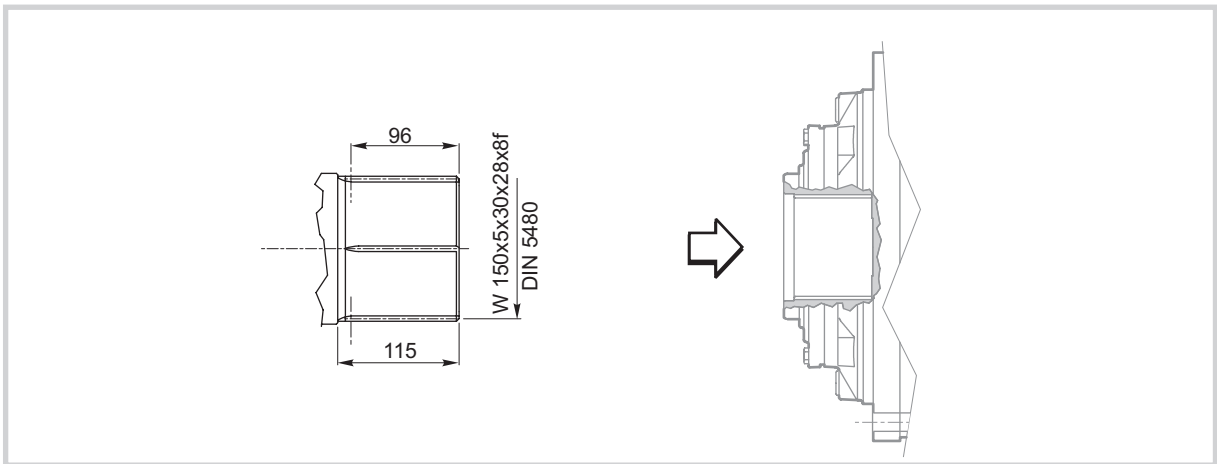
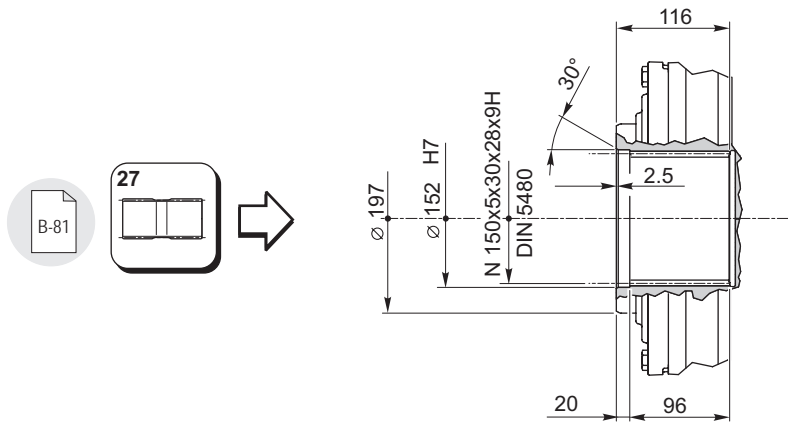
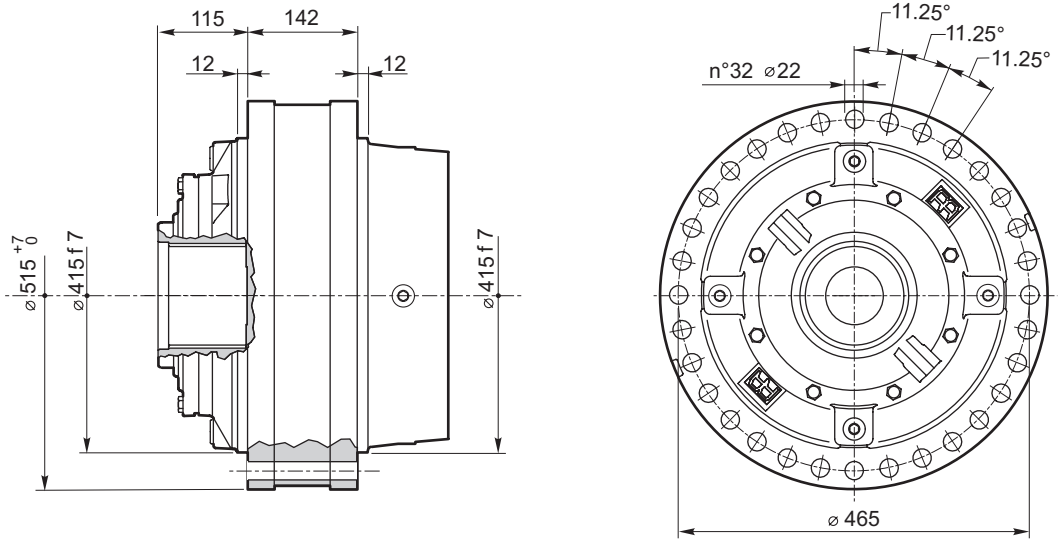

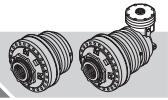

RR6500	L..	MH	i
RR6500	A..		i

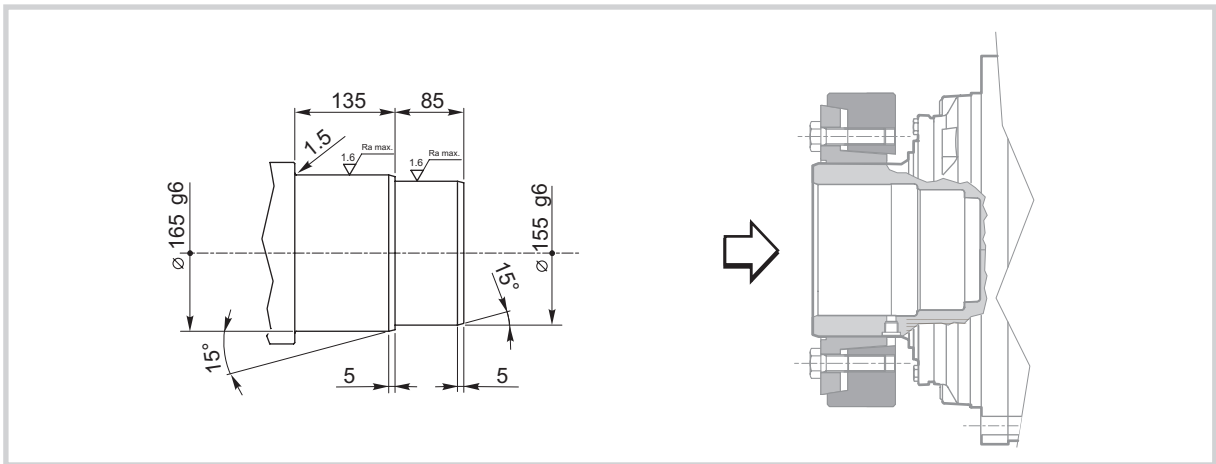
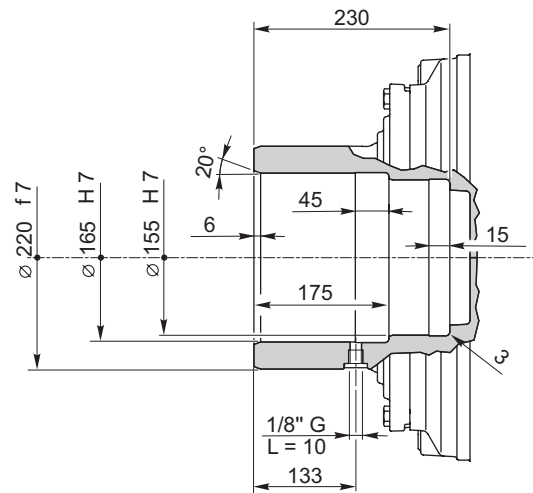
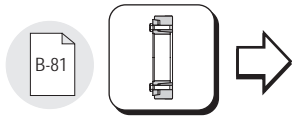
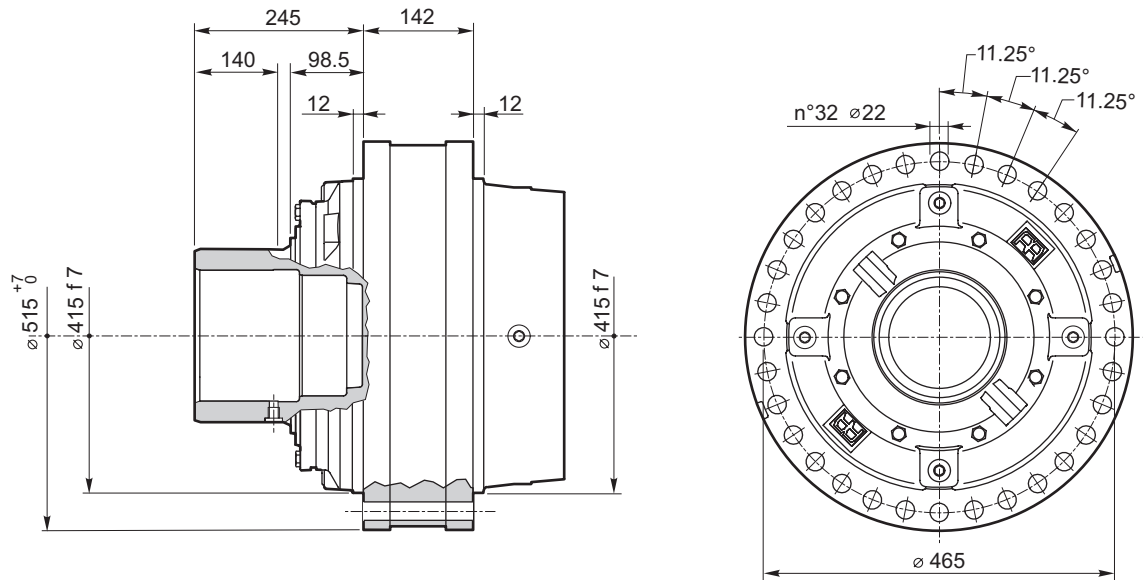



RR6500

IT EN DE FR ES PT

RR6500 L.. ZI i

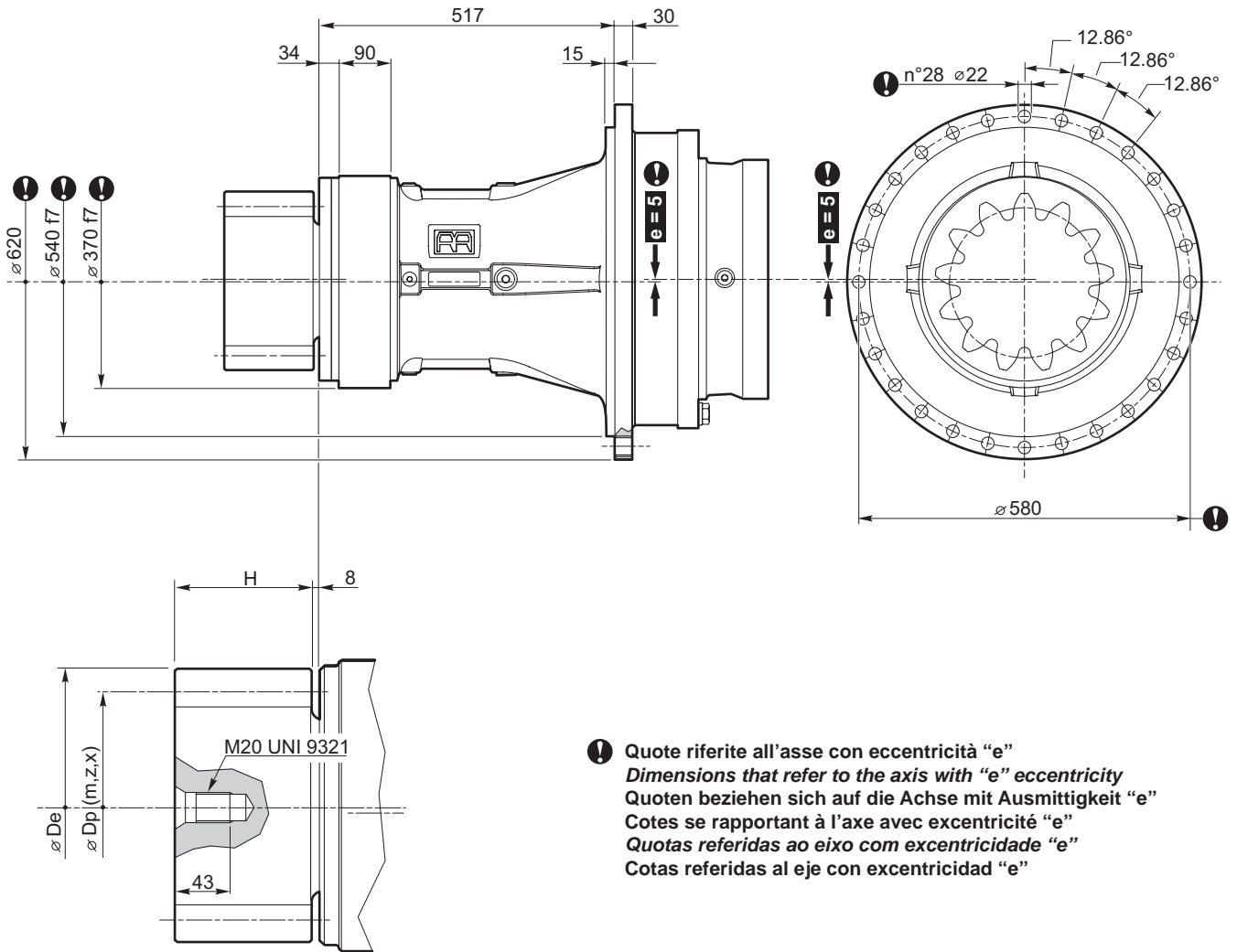

❗ **Quote riferite all'asse con eccentricità "e"**
Dimensions that refer to the axis with "e" eccentricity
Quoten beziehen sich auf die Achse mit Ausmittigkeit "e"
Cotes se rapportant à l'axe avec excentricité "e"
Quotas referidas ao eixo com excentricidade "e"
Cotas referidas al eje con excentricidad "e"

	m	z	x	H	Dp	De	code
	18	16	0.5	160	288	342	03-653
	20	15	0.5	160	300	360	03-652
	22	13	0.5	170	286	352	03-651

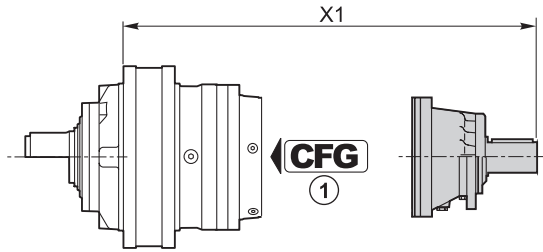
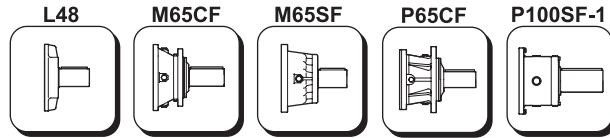
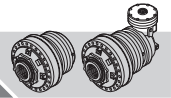

	CFG ①		code	X1
RR6500 L2	—	P100SF-1	154F3322	804
RR6500 L3	—	P65CF	154-2404	832.5
RR6500 L4	RF	M65SF	154B4249	773
	RF	M65CF	154-2407	796
	BOC	L48	154B3989	709.8

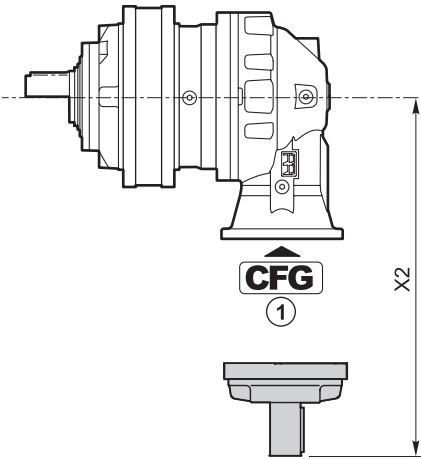

	CFG ①		code	X2
RR6500 A2	—	P100SF-1	154F3322	791.5
RR6500 A3(A)	—	P65CF	154-2404	600
RR6500 A3(B)	—	P65CF	154-2404	667
RR6500 A3(C)	—	P100SF-1	154F3322	791.5
RR6500 A4	BOC	L48	154B3989	347.8

CFG	
RF	
B C D	

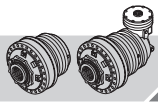

RR6500

IT EN DE FR ES PT

RF170-290



RF5/..

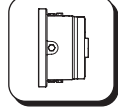

RFF5/..

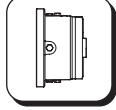

RF2/..

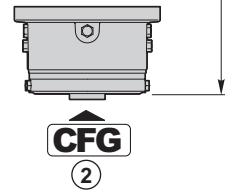
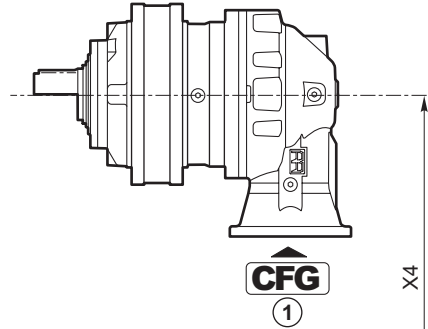
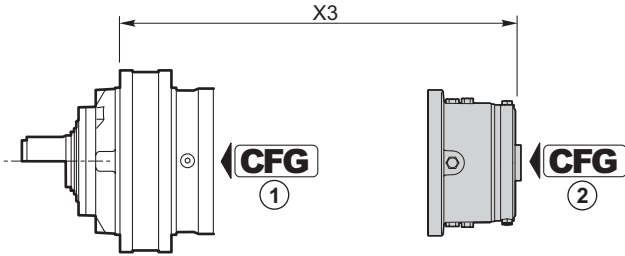
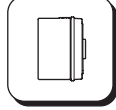

RF170-290	CFG ①	T _f [Nm]	CFG ②		
			C		
			code	X3	X4
RR6500 L3	RF	1700	154B9766M4	717.5	—
		2000	154B9767M4		
		2300	154B9768M4		
		2900	154B9769M4		
RR6500 A3(A)	—	1700	154B9766M3	—	485
		2000	154B9767M3		
		2300	154B9768M3		
		2900	154B9769M3		
RR6500 A3(B)	—	1700	154B9766M3	—	552
		2000	154B9767M3		
		2300	154B9768M3		
		2900	154B9769M3		

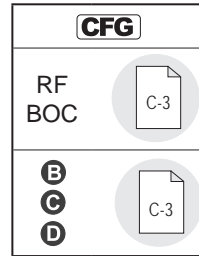

RF5/..	CFG ①	T _f [Nm]	CFG ②						
			B			OMTS 12/24 z16	OMVS 10/20 z16	X3	X4
			code	X3	X4	code	code	X3	X4
RR6500 L4	RF	210	154-2872	678.8	—	154-2879	154-2886	682.5	—
		290	154-2873			154-2880	154-2887		
		430	154-2874			154-2881	154-2888		
		650	154-2875			154-2882	154-2889		
		850	154-2876			154-2883	154-2890		
		1100	154-2877			154-2884	154-2891		
		1300	154-2878			154-2885	154-2892		



RFF5/..	CFG ①	T _r [Nm]	CFG ②						
			B			OMTS 12/24 z16	OMVS 10/20 z16		
			code	X3	X4	code	code	X3	X4
RR6500 A4	RF	210	154-2893	—	316.6	154-5338	154-5345	—	320.5
		290	154-2894			154-5339	154-5346		
		430	154-2895			154-5340	154-5347		
		650	154-2896			154-5341	154-5348		
		850	154-2897			154-5342	154-5349		
		1100	154-2898			154-5343	154-5350		
		1300	154-2899			154-5344	154-5351		

CFG	
RF	
B C D	

RF2/..	CFG ①	T _r [Nm]	CFG ②								
			B			OMP/OMR SAE A 2B Ø 25	OMP/OMR SAE A 2B 1" 6B	OMP/OMR SAE A 4B Ø 25	OMP/OMR SAE A 4B 1" 6B		
			code	X3	X4	code	code	code	code	X3	X4
RR6500 L4	RF	70	154-2345	651.3	—	154-2345M10	154-2345M11	154-2345M16	154-2345M17	641.3	—
		140	154-2346			154-2346M10	154-2346M11	154-2346M16	154-2346M17		
		210	154-2347			154-2347M10	154-2347M11	154-2347M16	154-2347M17		
		320	154-2348			154-2348M10	154-2348M11	154-2348M16	154-2348M17		
		430	154-2349			154-2349M10	154-2349M11	154-2349M16	154-2349M17		
		600	154B9186			154B9186M10	154B9186M11	154B9186M16	154B9186M17		
RR6500 A4	RF	70	154F2991	—	285.3						
		140	154F1890								
		210	154F2961								
		320	154B3591								
		430	154B3592								
		600	154F2992								

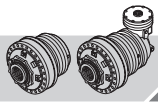

RR6500

IT EN DE FR ES PT

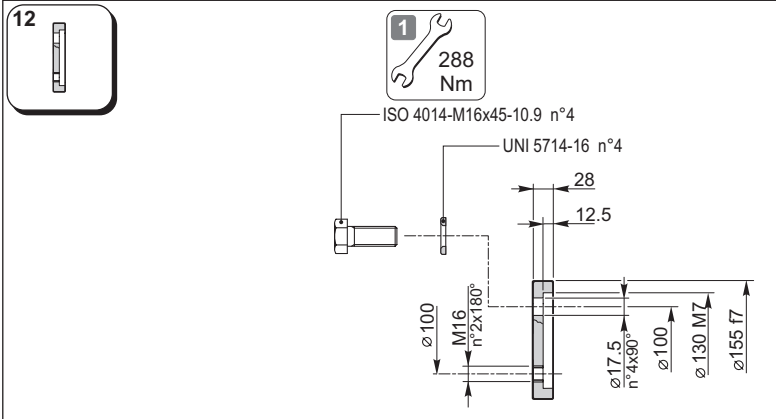

154F6033

Materiale / Material / Material / Matériau / Material / Material:
Acciaio / Steel / Stahl / Acier / Acero / Aço
EN 10083-1-42CrMo4+QT (1.7225)

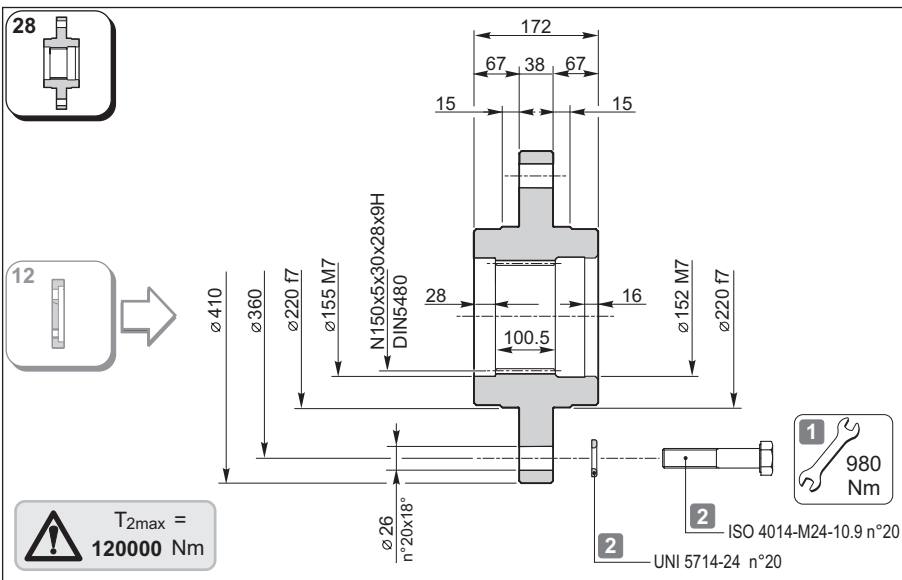

154F6051

Materiale / Material / Material
Matériau / Material / Material
Acciaio / Steel / Stahl / Acier / Acero / Aço
EN 10083-1-C40 (1.1186)

Trattamento termico:

Tempra ad induzione secondo UNI 10932 su scanalato interno

Heat treatment:

Induction hardening according to UNI 10932 on internal spline

Wärmebehandlung:

Induktionshärtung nach UNI 10932 an interner Nut

Traitement thermique:

Trempe par induction conformément à la norme UNI 10932 sur cannelé interne

Tratamiento térmico:

Temple por inducción según UNI 10932 en acanalado interno

Tratamento térmico:

Tempera por indução segundo UNI 10932 sobre ranhuras internas

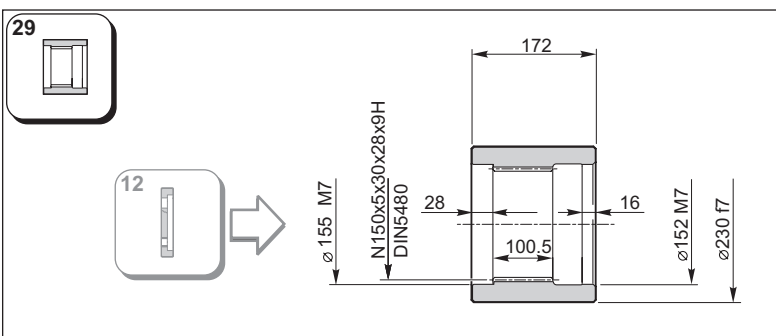

154F6059

Materiale / Material / Material / Matériau / Material / Material:
Acciaio / Steel / Stahl / Acier / Acero / Aço
EN 10083-1-42CrMo4+QT (1.7225)

Trattamento termico:

Tempra ad induzione secondo UNI 10932 su scanalato interno

Heat treatment:

Induction hardening according to UNI 10932 on internal spline

Wärmebehandlung:

Induktionshärtung nach UNI 10932 an interner Nut

Traitement thermique:

Trempe par induction conformément à la norme UNI 10932 sur cannelé interne

Tratamiento térmico:

Temple por inducción según UNI 10932 en acanalado interno

Tratamento térmico:

Tempera por indução segundo UNI 10932 sobre ranhuras internas

1 Coefficiente d'attrito medio considerato: 0.14
Average friction coefficient considered: 0.14
Durchschnittlicher berücksichtigter Reibungskoeffizient: 0.14
Coefficient de frottement moyen considéré: 0.14
Coeficiente medio de fricción considerado: 0.14
Coeficiente de atrito médio considerado: 0.14

2 Componenti non forniti da Reggiana Riduttori
Components not supplied by Reggiana Riduttori
Nicht von Reggiana Riduttori gelieferte Komponenten
Parties pas fournies par Reggiana Riduttori
Componentes no suministrados por Reggiana Riduttori
Componentes não fornecidos por Reggiana Riduttori

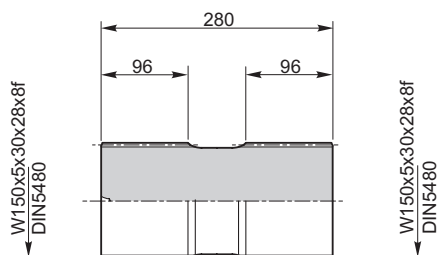
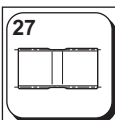
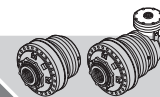

$T_{2max} =$
120000 Nm

Materiale / Material / Material / Matériau / Material / Material:
Acciaio / Steel / Stahl / Acier / Acero / Aço
EN 10083-1-42CrMo4+QT (1.7225)

154F6039

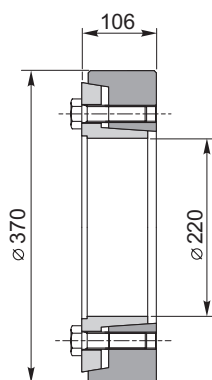
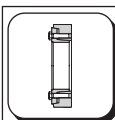

C-32

154F6067



$T_{2max} =$
xxxxxxx Nm

ATTENZIONE

Il valore di T_{2max} indicato costituisce una limitazione del valore relativo al riduttore, riportato nella tabella dei dati tecnici per ciascuna grandezza.

ATTENTION

The T_{2max} value indicated is a limit of the reduction gear value, given in the technical data table for each size.

ACHTUNG!

Der angegebene Wert T_{2max} stellt eine Einschränkung vom entsprechenden Wert am Untersetzungsgetriebe dar, der in der Tabelle mit den technischen Daten für jede Größe angegeben ist.

ATTENTION

Le valeur de T_{2max} indiquée représente une restriction de la valeur relative au réducteur et indiquée sur le tableau des caractéristiques techniques pour chaque grandeur.

ATENCIÓN

El valor de T_{2max} indicado constituye una limitación del valor referente al reductor, indicado en la tabla de los datos técnicos para cada talla.

ATENÇÃO

O valor T_{2max} indicado representa uma limitação do valor relativo ao redutor, indicado na tabela dos dados técnicos para cada grandeza.

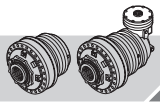

RR6500

IT EN DE FR ES PT

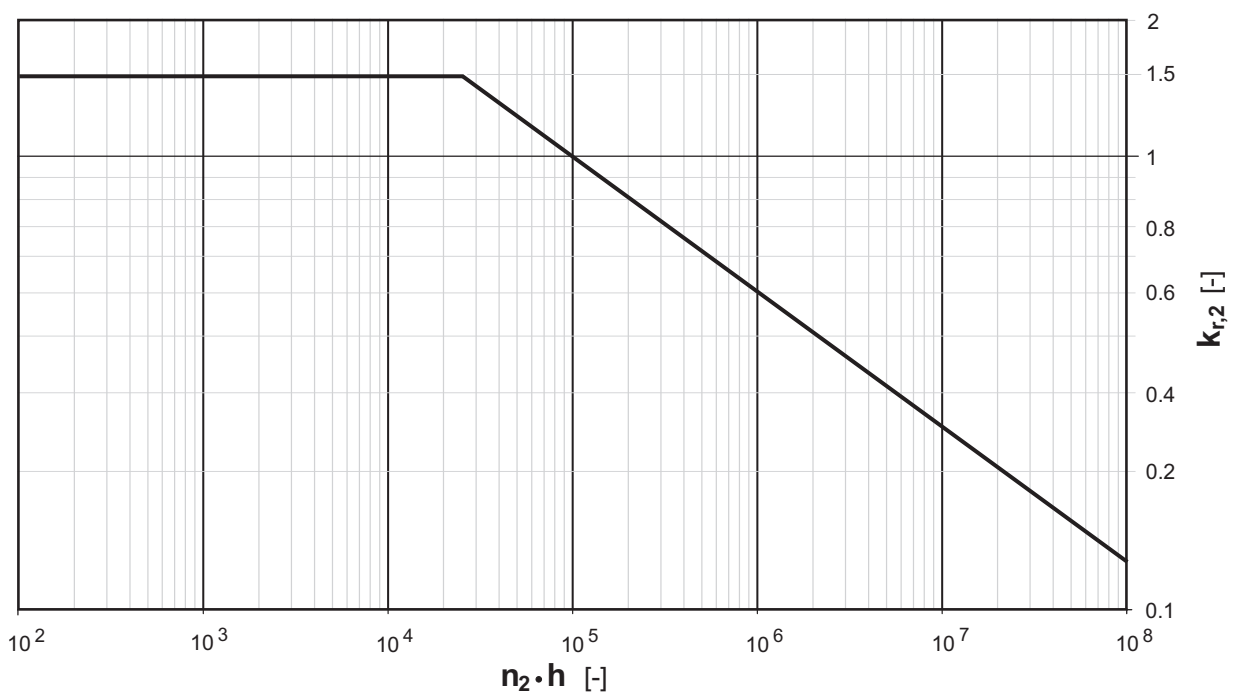
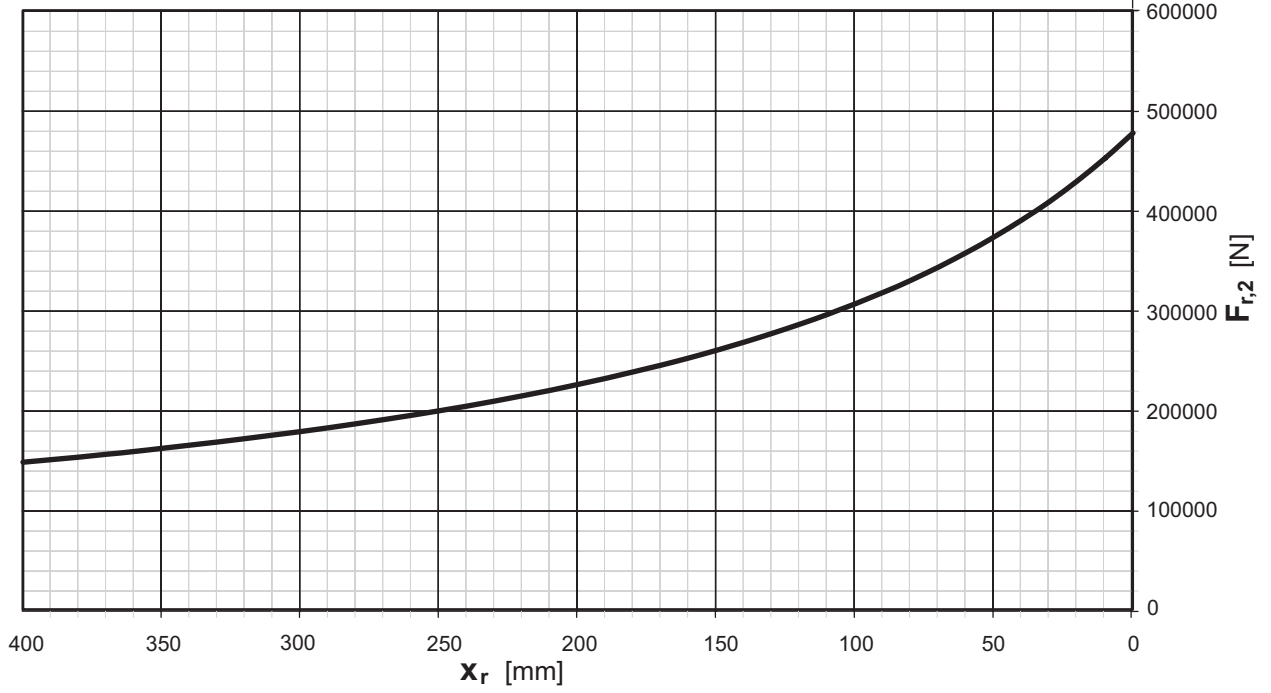
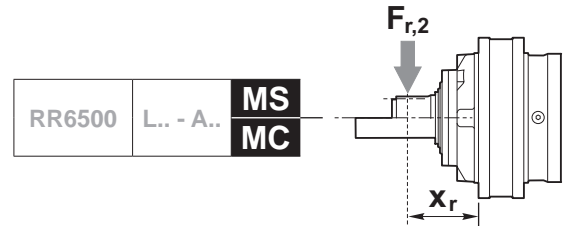

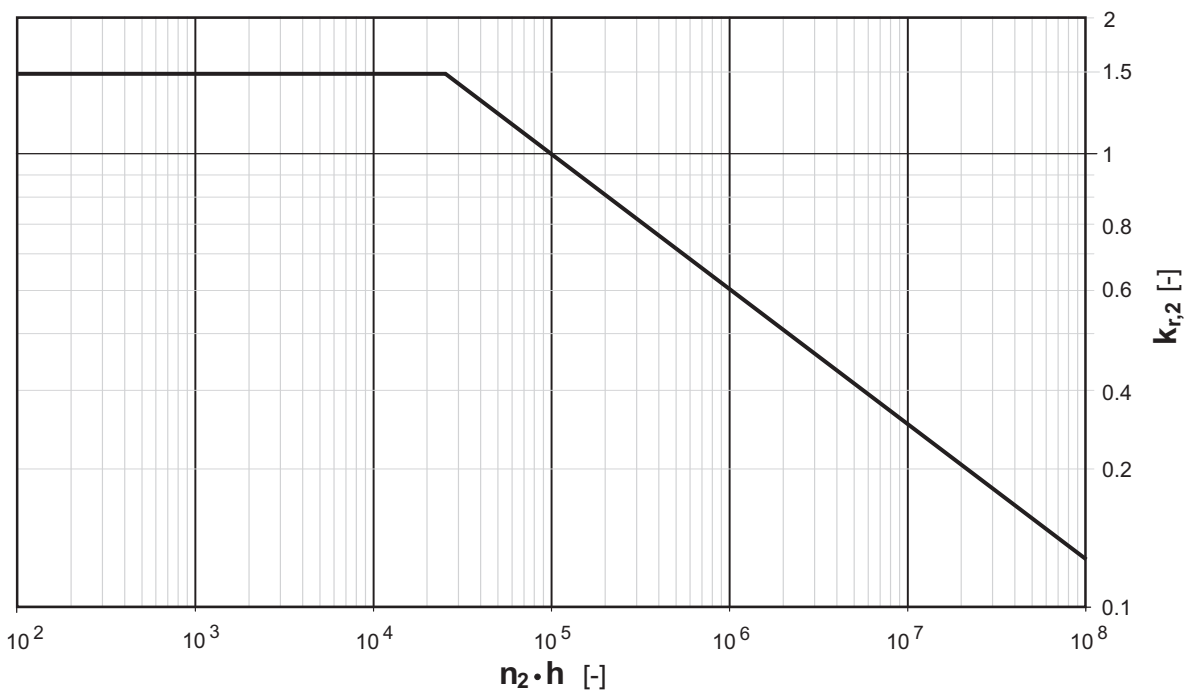
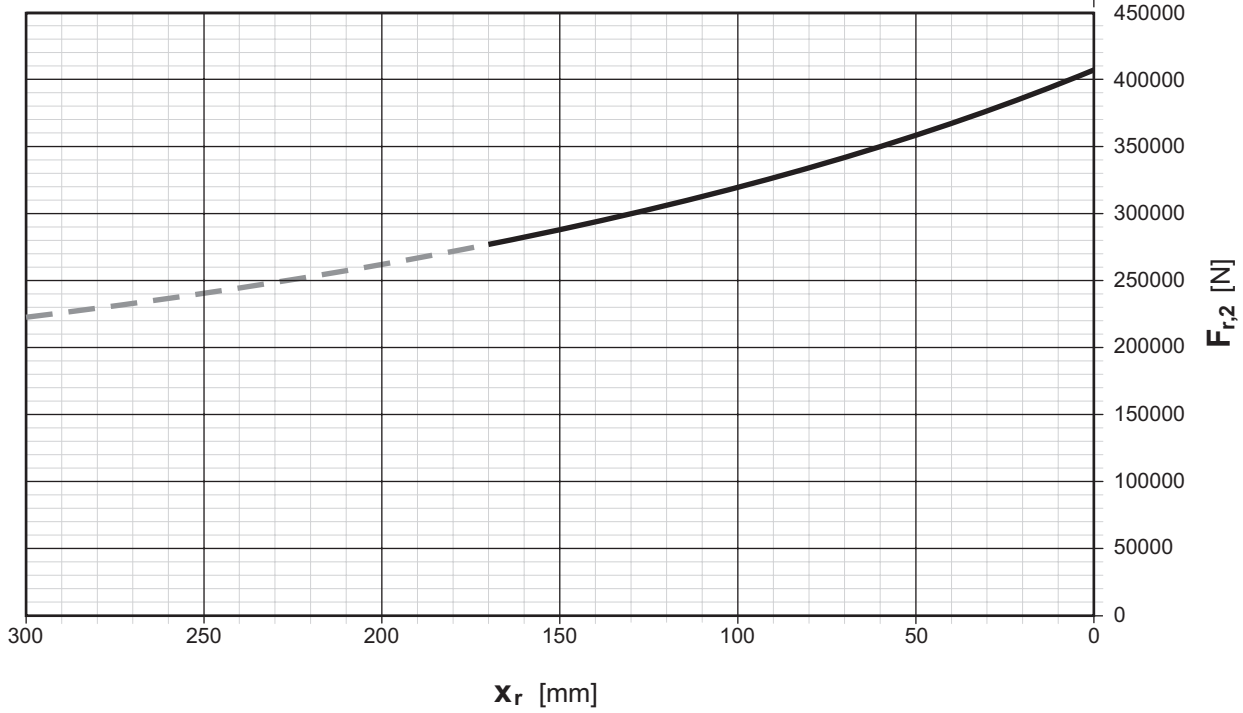
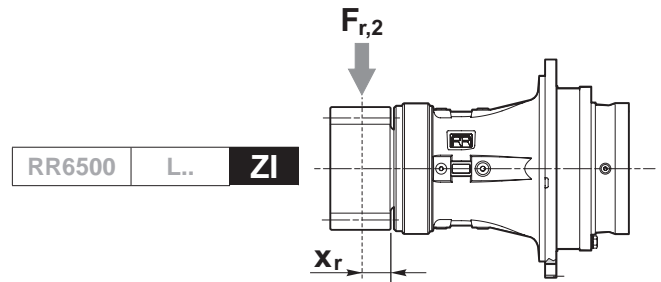



RR8000

IT EN DE FR ES PT

RR8000 L.. .. **i**



i	T ₂ [Nm]						n _{1max} [min ⁻¹]	T _{2max} [Nm]	P _t [kW]		
	n ₂ x h										
1/...	10000 (10 ⁴)	25000 (2.5 · 10 ⁴)	50000 (5 · 10 ⁴)	100000 (10 ⁵)	500000 (5 · 10 ⁵)	1000000 (10 ⁶)					
RR8000 L1	4.17	89660	82800	81650	75370	48550	39430	750	160000	94	
	4.65	80090	73450	69250	63080	48160	39120	750	160000	94	
	5.29	78580	67570	59540	55310	47110	38260	750	160000	94	
	6.21	63030	53270	46900	44600	40410	37950	750	160000	94	
RR8000 L2	17.42	89660	82800	81650	75370	48550	39430	1000	160000	59	
	19.41	89660	82800	81650	75370	48550	39430	1000	160000	59	
	22.10	89660	82800	81650	75370	48550	39430	1000	160000	59	
	25.94	89660	82800	81650	75370	48550	39430	1000	160000	59	
	28.90	80090	73450	69250	63080	48160	39120	1000	160000	59	
	32.90	78580	67570	59540	55310	47110	38260	1000	160000	59	
	38.62	63030	53270	46900	44600	40410	37950	1000	160000	59	
	RR8000 L3	67.94	89660	82800	81650	75370	48550	39430	2000	160000	43
76.86		89660	82800	81650	75370	48550	39430	2000	160000	43	
89.60		89660	82800	81650	75370	48550	39430	2000	160000	43	
99.82		89660	82800	81650	75370	48550	39430	2000	160000	43	
109.28		89660	82800	81650	75370	48550	39430	2000	160000	43	
121.75		89660	82800	81650	75370	48550	39430	2000	160000	43	
138.61		89660	82800	81650	75370	48550	39430	2000	160000	43	
162.70		89660	82800	81650	75370	48550	39430	2000	160000	43	
181.26		80090	73450	69250	63080	48160	39120	2000	160000	43	
206.37		78580	67570	59540	55310	47110	38260	2000	160000	43	
242.24		63030	53270	46900	44600	40410	37950	2000	160000	43	
RR8000 L4		231.01	89660	82800	81650	75370	48550	39430	3500	160000	34
		271.78	89660	82800	81650	75370	48550	39430	3500	160000	34
	307.44	89660	82800	81650	75370	48550	39430	3500	160000	34	
	358.39	89660	82800	81650	75370	48550	39430	3500	160000	34	
	399.26	89660	82800	81650	75370	48550	39430	3500	160000	34	
	447.98	89660	82800	81650	75370	48550	39430	3500	160000	34	
	499.08	89660	82800	81650	75370	48550	39430	3500	160000	34	
	565.43	89660	82800	81650	75370	48550	39430	3500	160000	34	
	633.83	89660	82800	81650	75370	48550	39430	3500	160000	34	
	708.10	89660	82800	81650	75370	48550	39430	3500	160000	34	
	801.02	89660	82800	81650	75370	48550	39430	3500	160000	34	
	852.22	89660	82800	81650	75370	48550	39430	3500	160000	34	
	970.27	89660	82800	81650	75370	48550	39430	3500	160000	34	
	1138.91	89660	82800	81650	75370	48550	39430	3500	160000	34	
	1268.82	80090	73450	69250	63080	48160	39120	3500	160000	34	
	1444.57	78580	67570	59540	55310	47110	38260	3500	160000	34	
	1695.65	63030	53270	46900	44600	40410	37950	3500	160000	34	

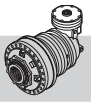

RR8000 A.. .. **i**



i	T ₂ [Nm]						n _{1max} [min ⁻¹]	T _{2max} [Nm]	P _t [kW]
	n ₂ x h								
	10000 (10 ⁴)	25000 (2.5 · 10 ⁴)	50000 (5 · 10 ⁴)	100000 (10 ⁵)	500000 (5 · 10 ⁵)	1000000 (10 ⁶)			

RR8000 A3 (A)	47.51	89660	68900	55960	45460	28050	22780	2500	160000	47
	52.93	89660	74310	60360	49030	30250	24570	2500	160000	47
	60.27	89660	81370	66090	53690	33130	26910	2500	160000	47
	70.74	89660	82800	73940	60060	37060	30100	2500	160000	47
	78.81	80090	73450	69250	63080	39970	32460	2500	160000	47
	89.72	78580	67570	59540	55310	43770	35550	2500	160000	47
	95.36	80090	73450	69250	62360	38480	31260	2500	160000	47
	108.57	78580	67570	59540	55310	42140	34230	2500	160000	47
	127.94	78580	67570	59540	55310	39770	32310	2500	160000	47
	150.18	63030	53270	46900	44600	40410	36140	2500	160000	47
(B)	48.24	89660	81810	66450	53980	33310	27050	2500	160000	50
	53.75	89660	82800	71670	58220	35920	29180	2500	160000	50
	61.19	89660	82800	78490	63750	39340	31950	2500	160000	50
	71.83	89660	82800	81650	71320	44010	35740	2500	160000	50
	80.02	80090	73450	69250	63080	47460	38550	2500	160000	50
	91.51	80090	73450	69250	63080	48060	39040	2500	160000	50
	106.11	89660	82800	81650	71780	44290	35980	2500	160000	50
	118.21	80090	73450	69250	63080	47770	38800	2500	160000	50
	134.59	78580	67570	59540	55310	47110	38260	2500	160000	50
157.98	63030	53270	46900	44600	40410	37950	2500	160000	50	
(C)	42.88	89660	82800	81650	75370	48550	39430	2000	160000	58
	55.17	89660	82800	81650	75370	48550	39430	2000	160000	58
	66.52	89660	82800	81650	75370	48550	39430	2000	160000	58
	74.11	89660	82800	81650	75370	48550	39430	2000	160000	58
	84.37	89660	82800	81650	75370	48550	39430	2000	160000	58
	99.04	89660	82800	81650	75370	48550	39430	2000	160000	58
	110.33	80090	73450	69250	63080	48160	39120	2000	160000	58
	125.61	78580	67570	59540	55310	47110	38260	2000	160000	58
	147.45	63030	53270	46900	44600	40410	37950	2000	160000	58

RR8000 A4 (A)	182.93	89660	71320	57930	47050	29030	23580	3500	160000	36	
	206.93	89660	77750	63150	51290	31650	25710	3500	160000	36	
	241.22	89660	82800	70300	57100	35240	28620	3500	160000	36	
	268.74	89660	82800	75830	61590	38000	30870	3500	160000	36	
	294.22	89660	82800	80790	65620	40490	32890	3500	160000	36	
	327.78	89660	82800	81650	70780	43670	35470	3500	160000	36	
	373.18	89660	82800	81650	75370	47820	38840	3500	160000	36	
	438.04	89660	82800	81650	75370	48550	39430	3500	160000	36	
	513.13	89660	82800	81650	75370	48550	39430	3500	160000	36	
	554.44	89660	82800	81650	73130	45120	36650	3500	160000	36	
	650.81	89660	82800	81650	75370	48550	39430	3500	160000	36	
	725.04	80090	73450	69250	63080	48160	39120	3500	160000	36	
	825.47	78580	67570	59540	55310	47110	38260	3500	160000	36	
	968.94	63030	53270	46900	44600	40410	37950	3500	160000	36	
	(B)	185.30	89660	82800	81650	75370	48550	39430	2500	160000	39
		224.22	89660	82800	81650	75370	48550	39430	2500	160000	39
264.23		89660	82800	81650	75370	48550	39430	2500	160000	39	
298.04		89660	82800	81650	75370	48550	39430	2500	160000	39	
348.43		89660	82800	81650	75370	48550	39430	2500	160000	39	
401.76		89660	82800	81650	75370	48550	39430	2500	160000	39	
473.45		89660	82800	81650	75370	48550	39430	2500	160000	39	
539.04		89660	82800	81650	75370	48550	39430	2500	160000	39	
632.73		89660	82800	81650	75370	48550	39430	2500	160000	39	
704.90		80090	73450	69250	63080	48160	39120	2500	160000	39	
802.54		78580	67570	59540	55310	47110	38260	2500	160000	39	
942.03		63030	53270	46900	44600	40410	37950	2500	160000	39	



RR8000

IT EN DE FR ES PT

RR8000 L.. .. i



L1

MS MC FS MH 318 RR8000 L1

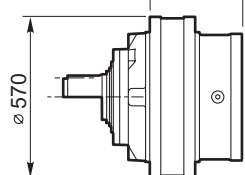

L2

MS MC FS MH 523 RR8000 L2

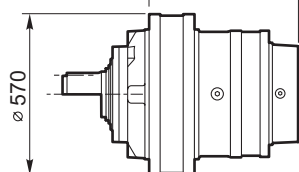

L3

MS MC FS MH 638 RR8000 L3

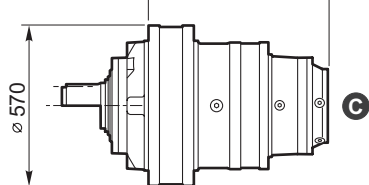

ZI 638 RR8000 L3

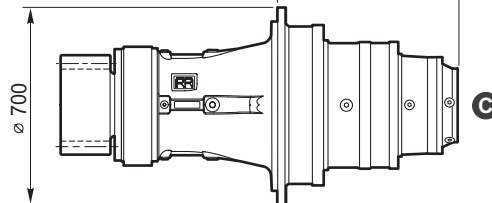

L4

MS MC FS MH 714 RR8000 L4

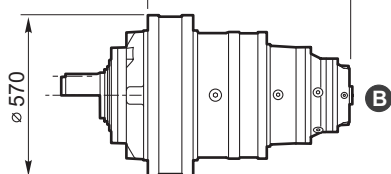

ZI 714 RR8000 L4

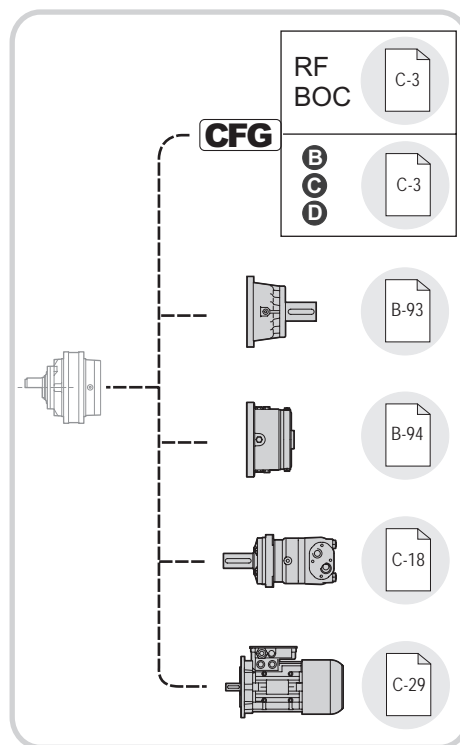
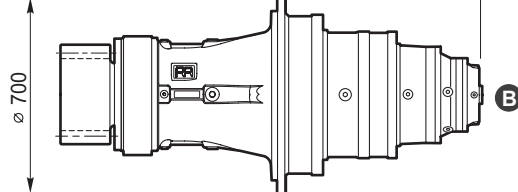

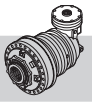

RR8000 A.. .. i

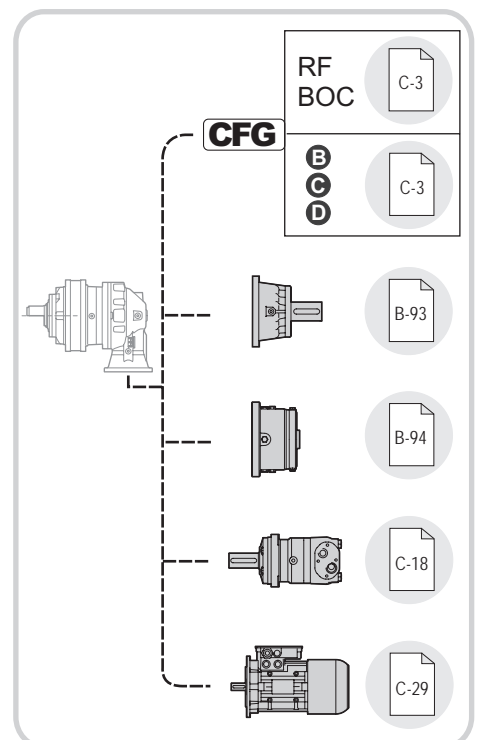
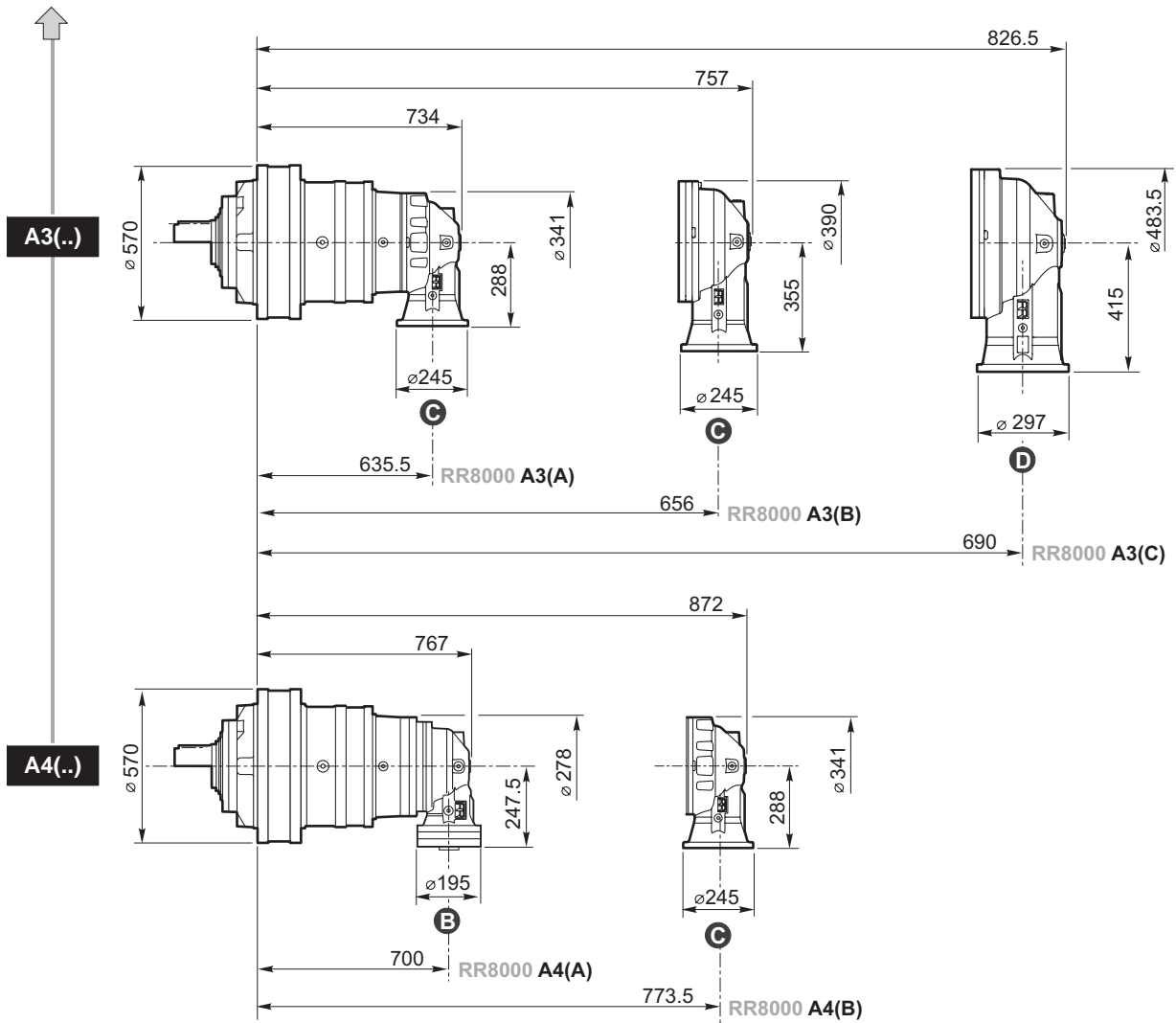

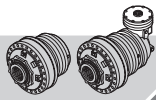

RR8000

IT EN DE FR ES PT

RR8000	L..	MS	i
RR8000	A..		i

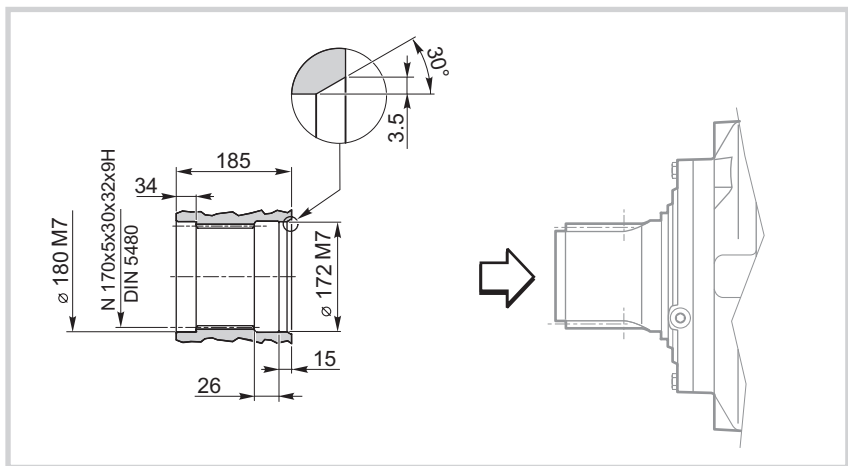
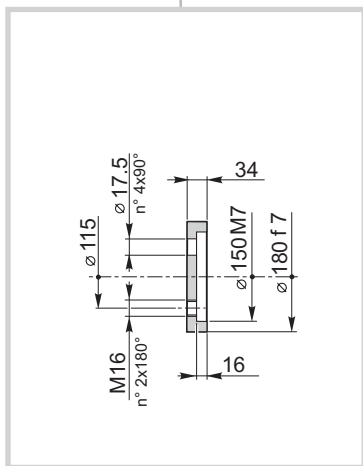
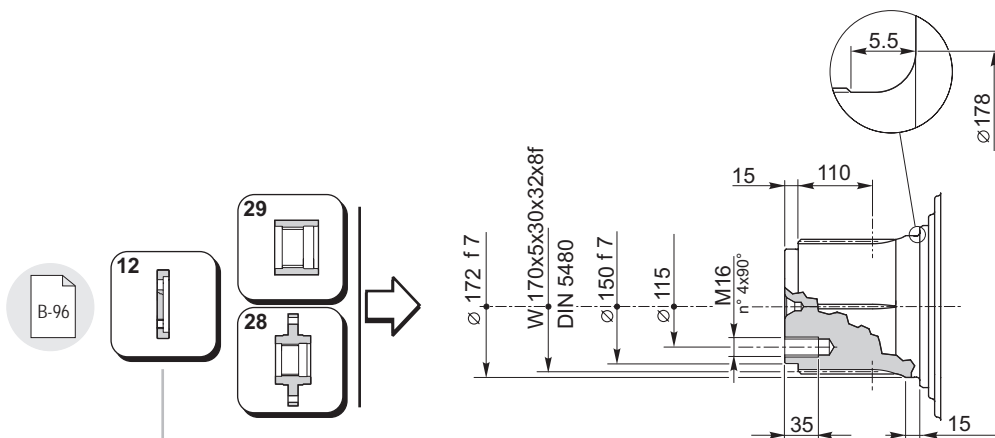
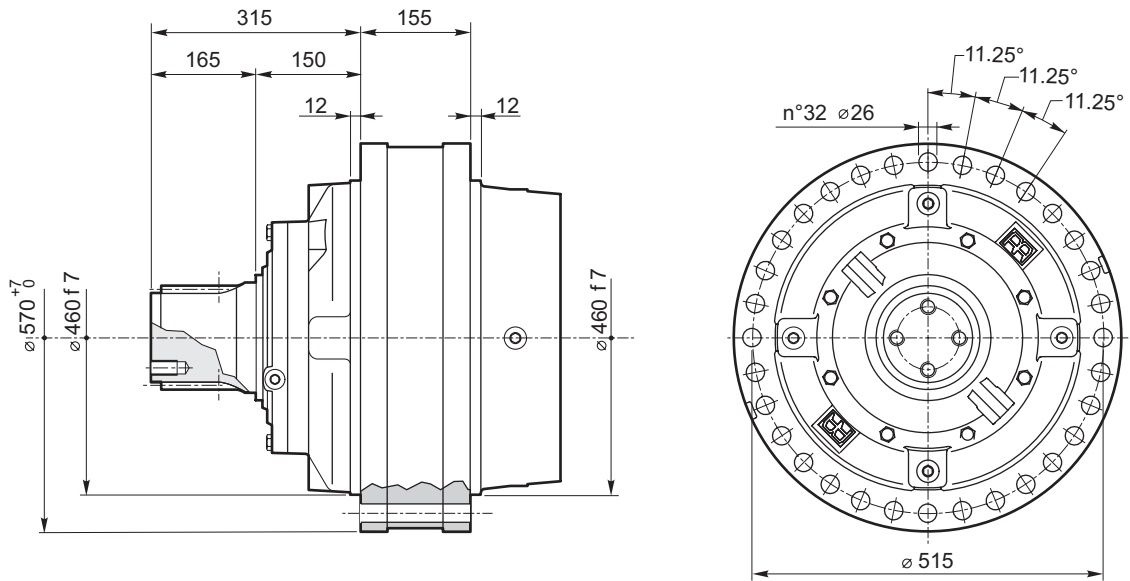

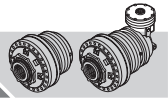

RR8000	L..	MC	i
RR8000	A..		i

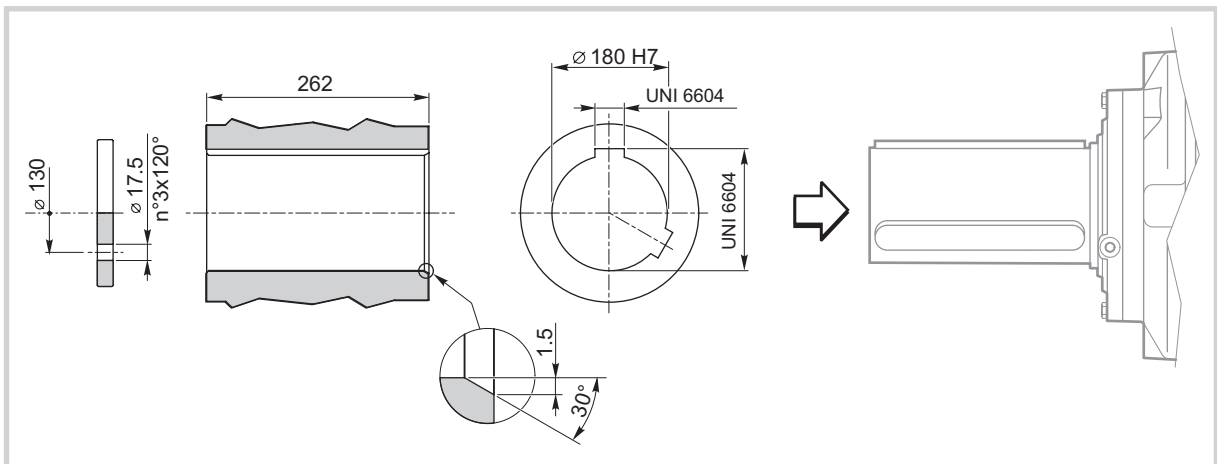
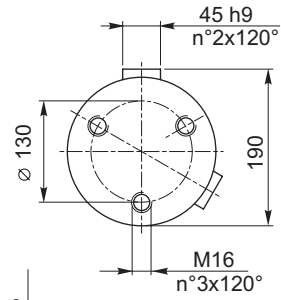
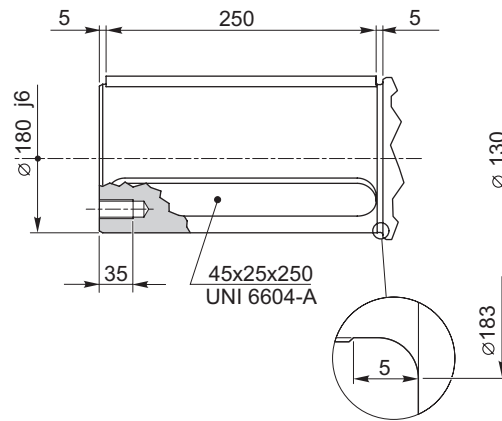
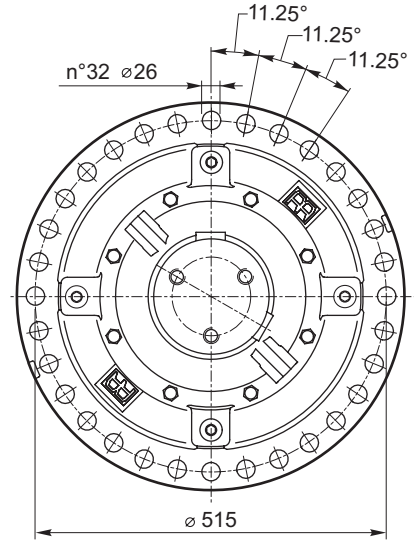
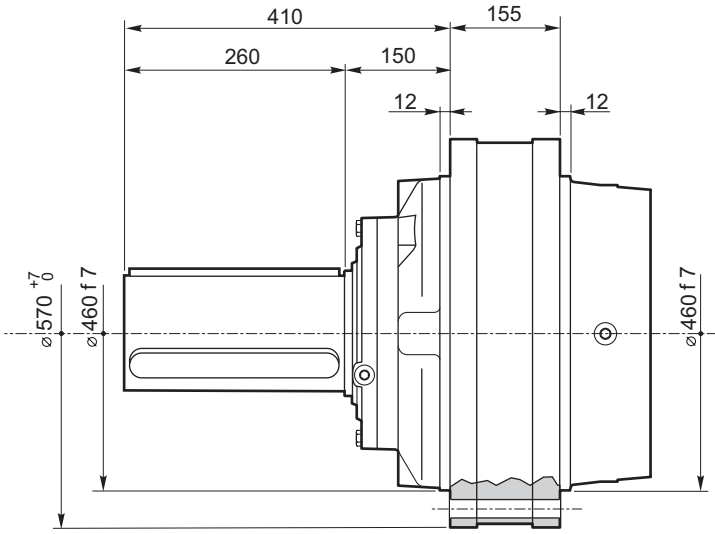

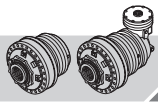

RR8000

IT EN DEFRES PT

RR8000	L..	FS	i
RR8000	A..		i

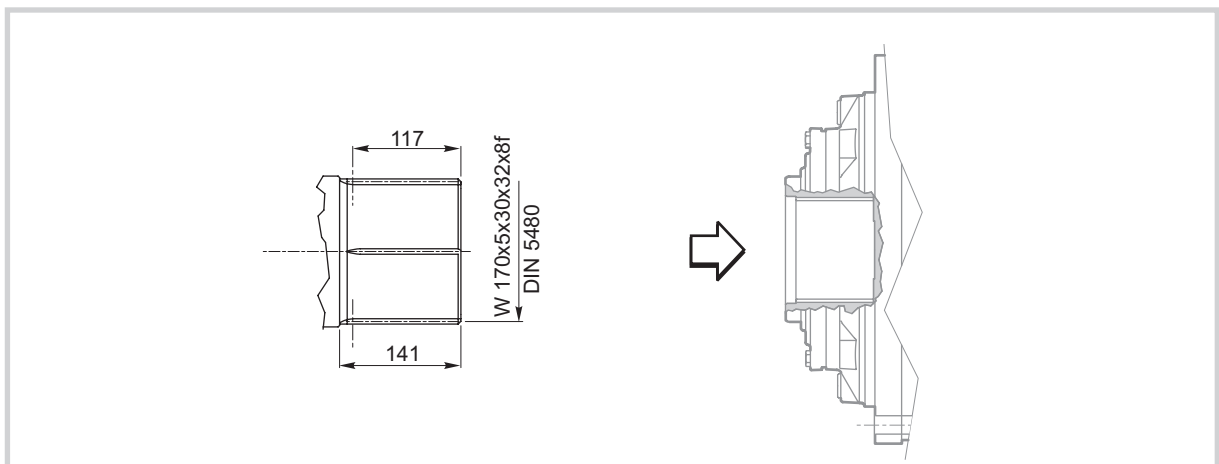
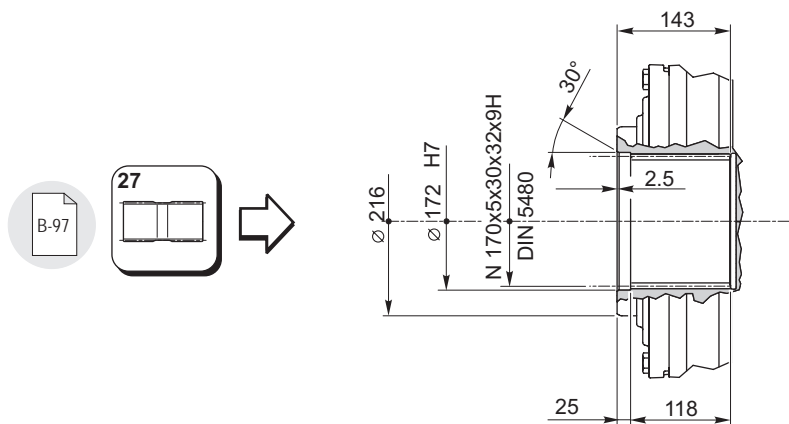
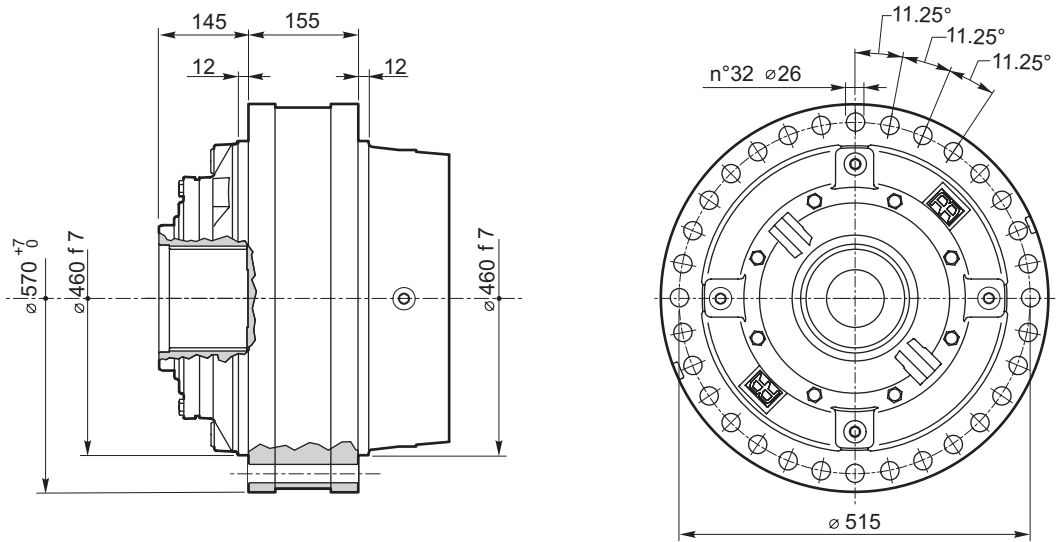

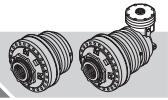

RR8000	L..	MH	i
RR8000	A..		i

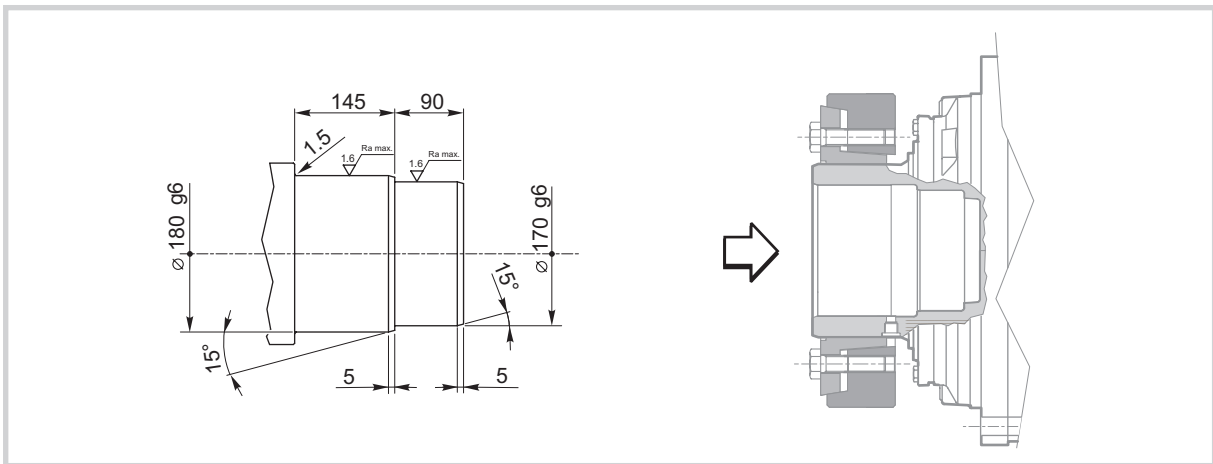
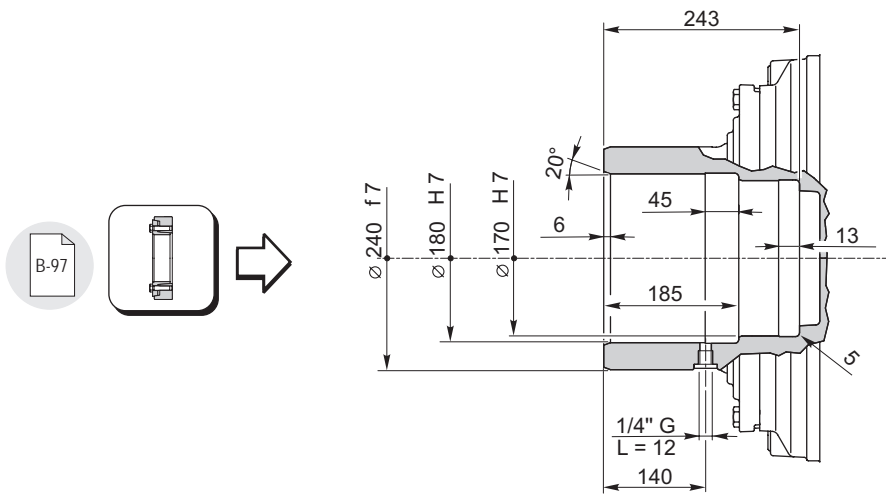
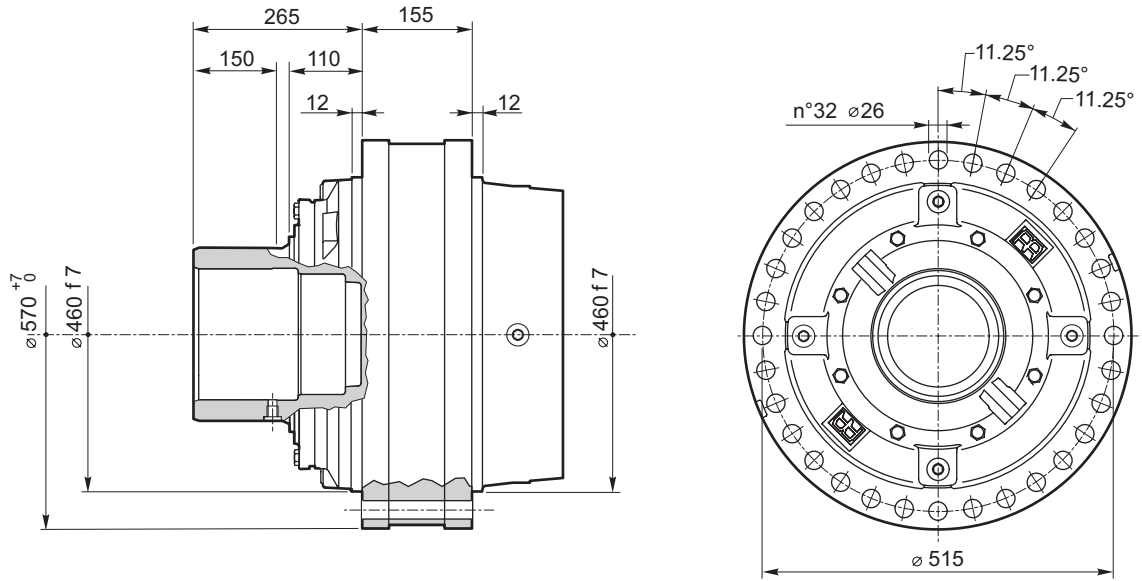



RR8000

IT EN DE FR ES PT

RR8000 L.. ZI i

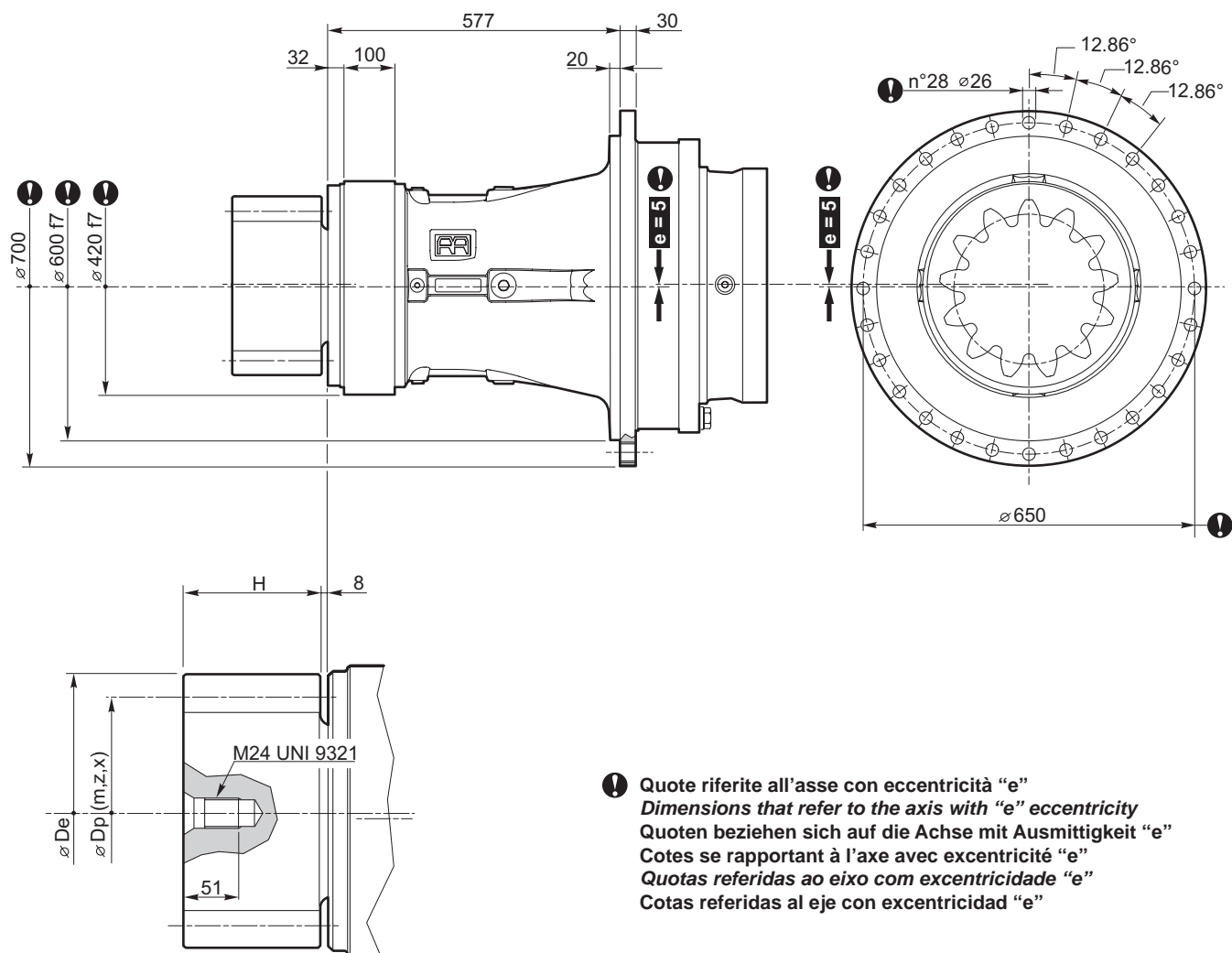

	m	z	x	H	Dp	De	code
	20	15	0.5	200	300	360	03-639
	22	14	0.5	220	308	374	03-640
	24	14	0.5	220	336	408	03-641

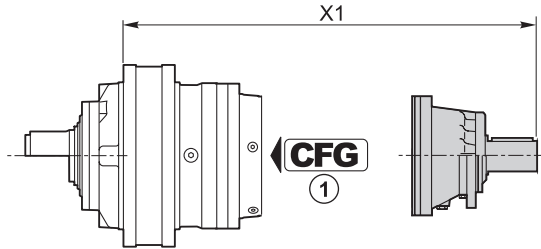
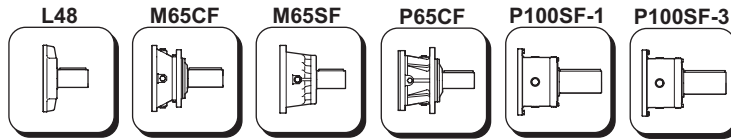
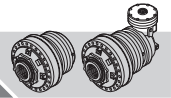

	CFG ①		code	X1
RR8000 L2	—	P100SF-3	154F3324	900
RR8000 L3	—	P65CF	154-2404	950
RR8000 L4	RF	M65SF	154B4249	898.5
	RF	M65CF	154-2407	921.5
	BOC	L48	154B3989	835.3

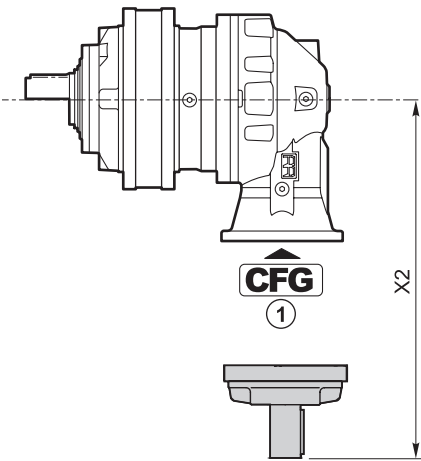

	CFG ①		code	X2
RR8000 A3(A)	—	P65CF	154-2404	600
RR8000 A3(B)	—	P65CF	154-2404	667
RR8000 A3(C)	—	P100SF-1	154F3322	791.5
RR8000 A4(A)	BOC	L48	154B3989	347.8
RR8000 A4(B)	—	P65CF	154-2404	600

CFG	
RF BOC	C-3
B C D	C-3

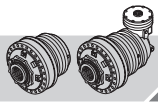

RR8000

IT EN DE FR ES PT

RF170-290



RF5/..

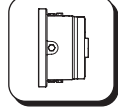

RFF5/..

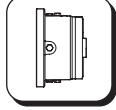

RF2/..

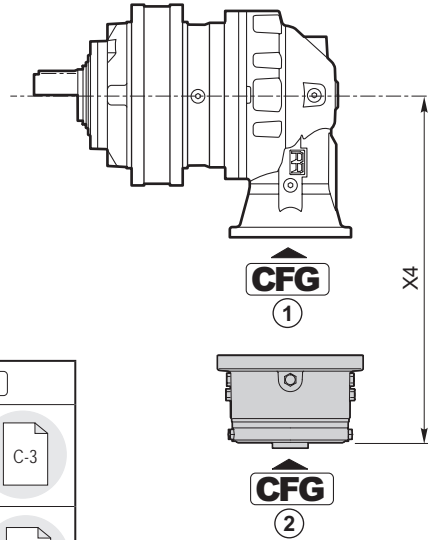
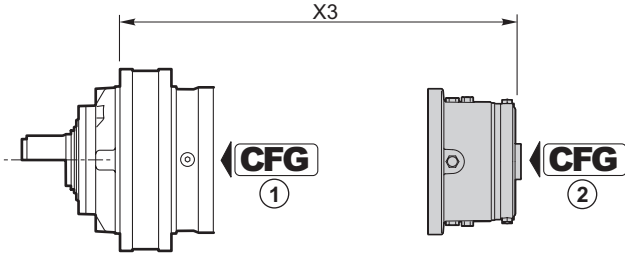
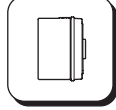

RF170-290	CFG ①	T _f [Nm]	CFG ②		
			C		
			code	X3	X4
RR8000 L3	RF	1700	154B9766M2	835	—
		2000	154B9767M2		
		2300	154B9768M2		
		2900	154B9769M2		
RR8000 A3(A)	—	1700	154B9766M3	—	485
		2000	154B9767M3		
		2300	154B9768M3		
		2900	154B9769M3		
RR8000 A3(B)	—	1700	154B9766M3	—	552
		2000	154B9767M3		
		2300	154B9768M3		
		2900	154B9769M3		
RR8000 A4(B)	—	1700	154B9766M3	—	485
		2000	154B9767M3		
		2300	154B9768M3		
		2900	154B9769M3		

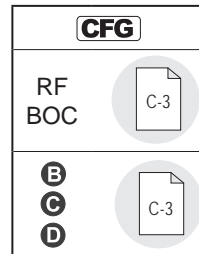

RF5/..	CFG ①	T _f [Nm]	CFG ②						
			B			OMTS 12/24 z16	OMVS 10/20 z16		
			code	X3	X4	code	code	X3	X4
RR8000 L4	RF	210	154-2872	804.3	—	154-2879	154-2886	808	—
		290	154-2873			154-2880	154-2887		
		430	154-2874			154-2881	154-2888		
		650	154-2875			154-2882	154-2889		
		850	154-2876			154-2883	154-2890		
		1100	154-2877			154-2884	154-2891		
		1300	154-2878			154-2885	154-2892		



RFF5/..	CFG ①	T _f [Nm]	CFG ②							
			B			OMTS 12/24 z16	OMVS 10/20 z16			
			code	X3	X4	code	code	X3	X4	
RR8000 A4(A)	RF	210	154-2893	—	316.6	154-5338	154-5345	—	320.5	
		290	154-2894			154-5339	154-5346			
		430	154-2895			154-5340	154-5347			
		650	154-2896			154-5341	154-5348			
		850	154-2897			154-5342	154-5349			
		1100	154-2898			154-5343	154-5350			
		1300	154-2899			154-5344	154-5351			

CFG	
RF	
B C D	

RF2/..	CFG ①	T _f [Nm]	CFG ②								
			B			OMP/OMR SAE A 2B Ø 25	OMP/OMR SAE A 2B 1" 6B	OMP/OMR SAE A 4B Ø 25	OMP/OMR SAE A 4B 1" 6B		
			code	X3	X4	code	code	code	code	X3	X4
RR8000 L4	RF	70	154B9195	776.8	—	154B9195M10	—	154B9195M16	154B9195M17	766.8	—
		140	154B9196			154B9196M10	—	154B9196M16	154B9196M17		
		210	154B9197			154B9197M10	—	154B9197M16	154B9197M17		
		320	154B9198			154B9198M10	—	154B9198M16	154B9198M17		
		430	154B9199			154B9199M10	—	154B9199M16	154B9199M17		
		600	154B9200			154B9200M10	—	154B9200M16	154B9200M17		
RR8000 A4(A)	RF	70	154F2991	—	285.3						
		140	154F1890								
		210	154F2961								
		320	154B3591								
		430	154B3592								
		600	154F2992								

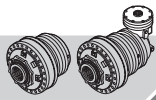

RR8000

IT EN DE FR ES PT

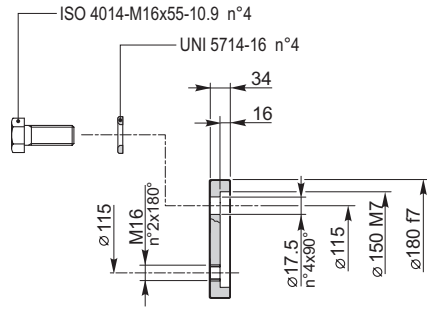
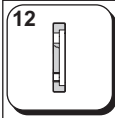

154F6034

Materiale / Material / Material / Matériau / Material / Material:
Acciaio / Steel / Stahl / Acier / Acero / Aço
EN 10083-1-42CrMo4+QT (1.7225)

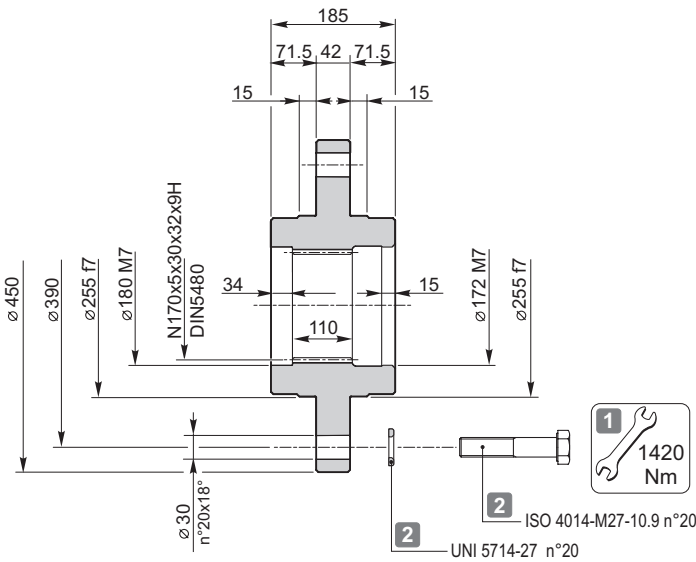
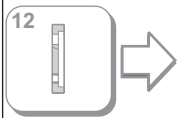
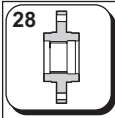

154F6052

Materiale / Material / Material
Matériau / Material / Material
Acciaio / Steel / Stahl / Acier / Acero / Aço
EN 10083-1-C40 (1.1186)

Trattamento termico:

Tempra ad induzione secondo UNI 10932 su scanalato interno

Heat treatment:

Induction hardening according to UNI 10932 on internal spline

Wärmebehandlung:

Induktionshärtung nach UNI 10932 an interner Nut

Traitement thermique:

Trempe par induction conformément à la norme UNI 10932 sur cannelé interne

Tratamiento térmico:

Temple por inducción según UNI 10932 en acanalado interno

Tratamento térmico:

Tempera por indução segundo UNI 10932 sobre ranhuras internas

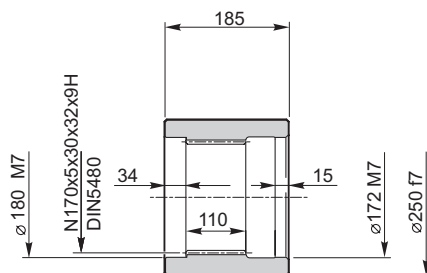
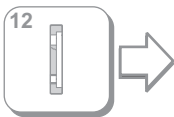

154F6060

Materiale / Materiale / Material / Matériau / Material / Material:
Acciaio / Steel / Stahl / Acier / Acero / Aço
EN 10083-1-42CrMo4+QT (1.7225)

Trattamento termico:

Tempra ad induzione secondo UNI 10932 su scanalato interno

Heat treatment:

Induction hardening according to UNI 10932 on internal spline

Wärmebehandlung:

Induktionshärtung nach UNI 10932 an interner Nut

Traitement thermique:

Trempe par induction conformément à la norme UNI 10932 sur cannelé interne

Tratamiento térmico:

Temple por inducción según UNI 10932 en acanalado interno

Tratamento térmico:

Tempera por indução segundo UNI 10932 sobre ranhuras internas

1 Coefficiente d'attrito medio considerato: 0.14
Average friction coefficient considered: 0.14
Durchschnittlicher berücksichtigter Reibungskoeffizient: 0.14
Coefficient de frottement moyen considéré: 0.14
Coeficiente medio de fricción considerado: 0.14
Coeficiente de atrito médio considerado: 0.14

2 Componenti non forniti da Reggiana Riduttori
Components not supplied by Reggiana Riduttori
Nicht von Reggiana Riduttori gelieferte Komponenten
Parties pas fournies par Reggiana Riduttori
Componentes no suministrados por Reggiana Riduttori
Componentes não fornecidos por Reggiana Riduttori

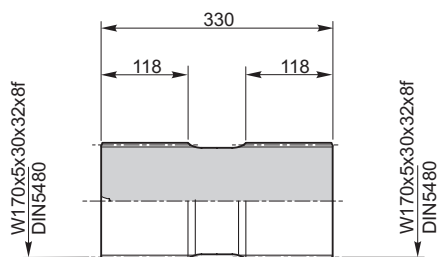
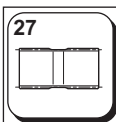
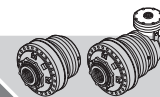

Materiale / Material / Material / Matériau / Material / Material:
 Acciaio / Steel / Stahl / Acier / Acero / Aço
 EN 10083-1-42CrMo4+QT (1.7225)

154F6040

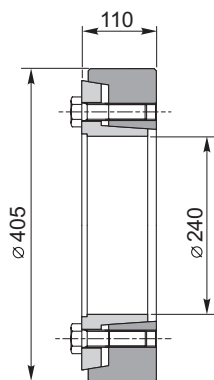
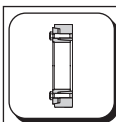

154F6068

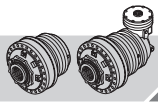

RR8000

IT EN DEFRES PT

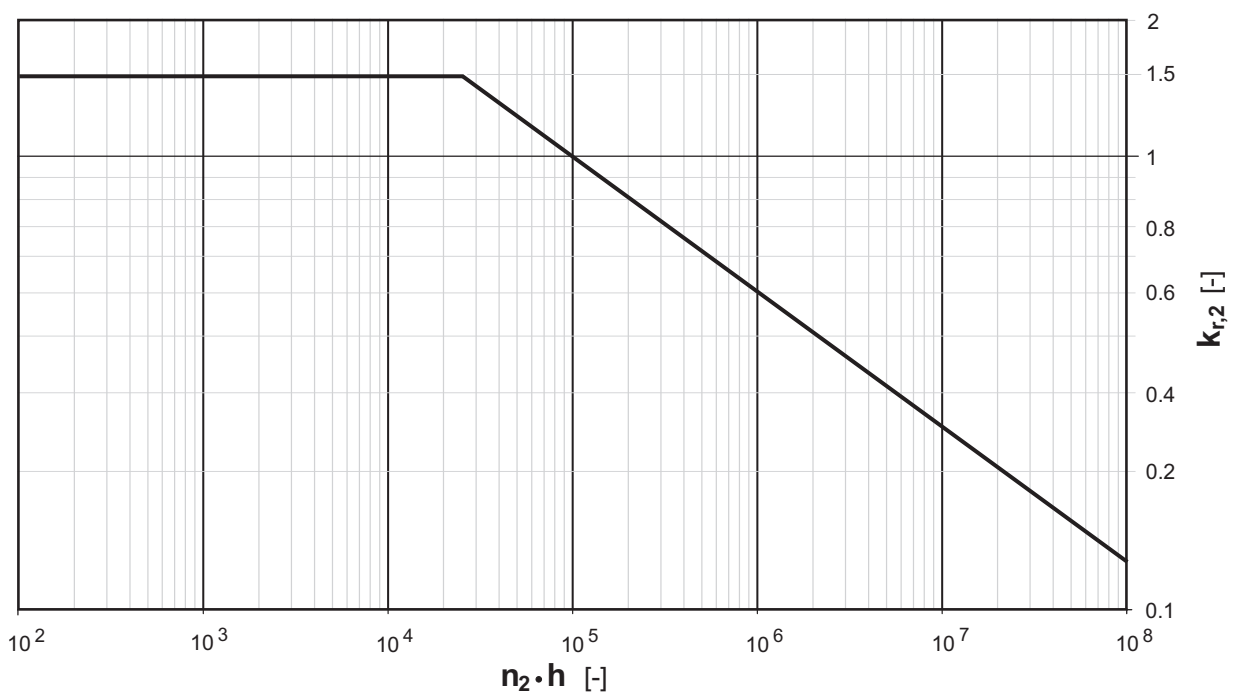
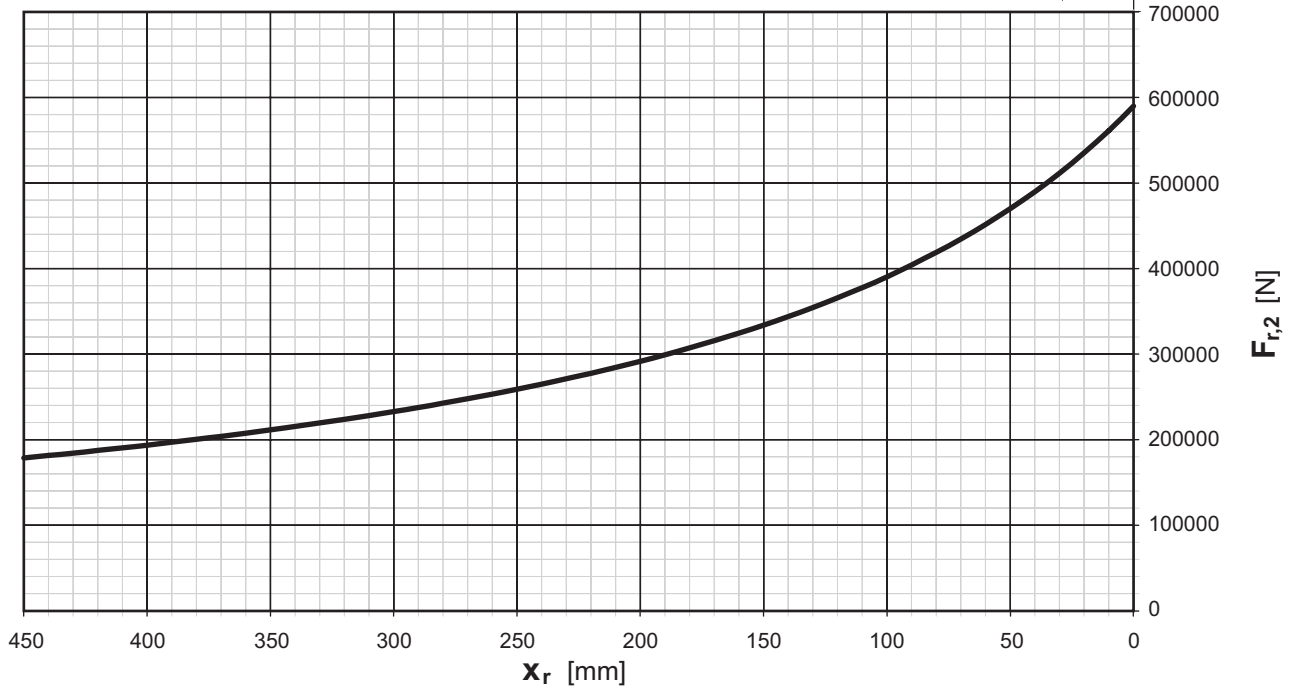
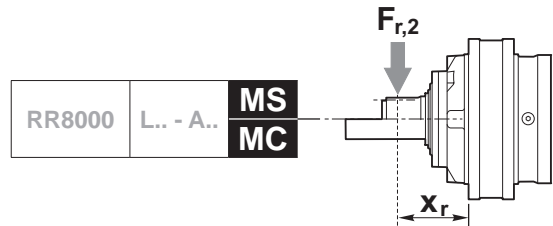

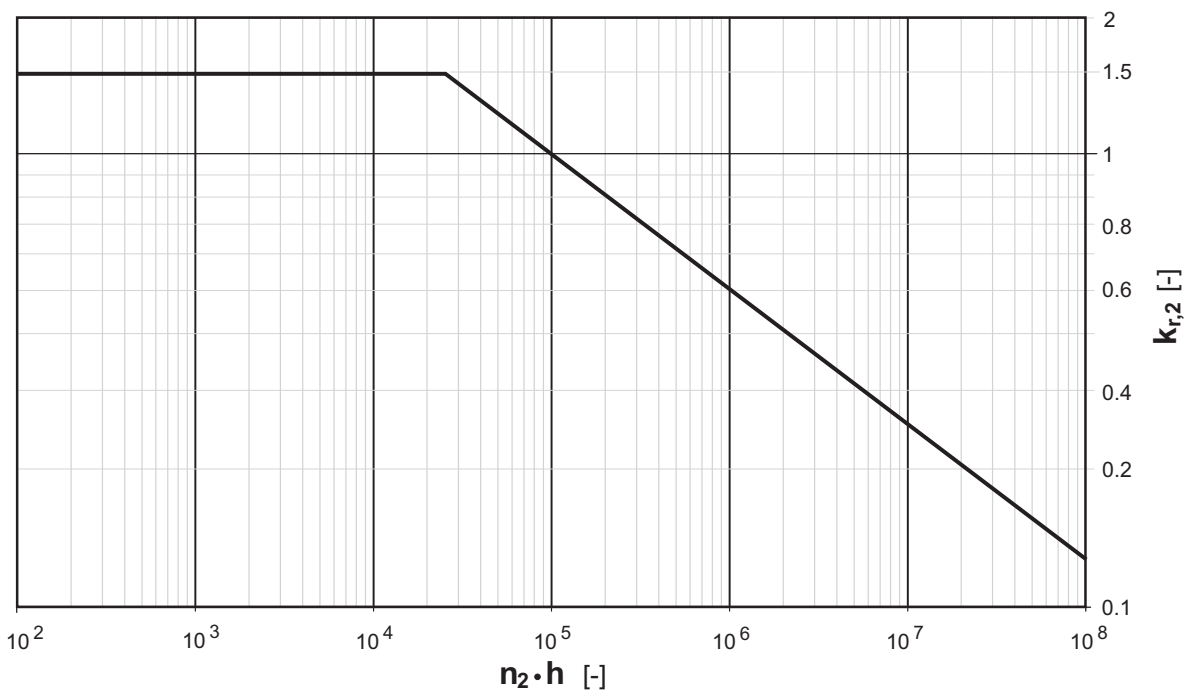
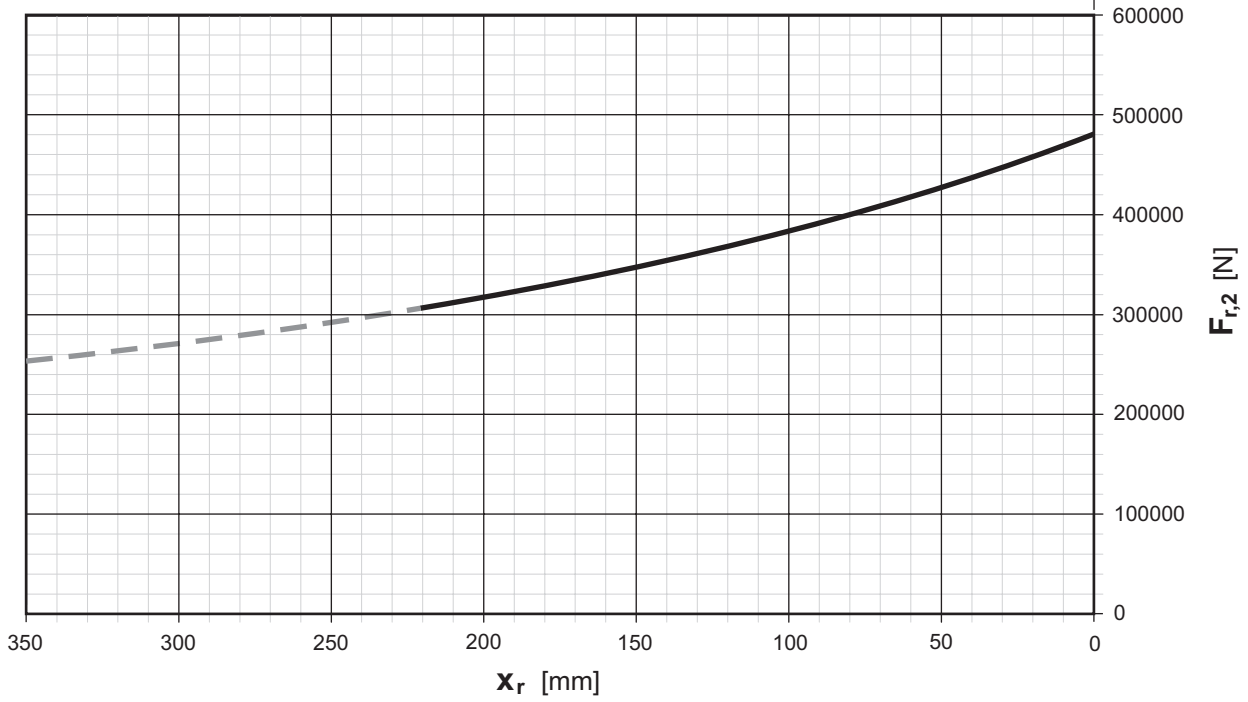
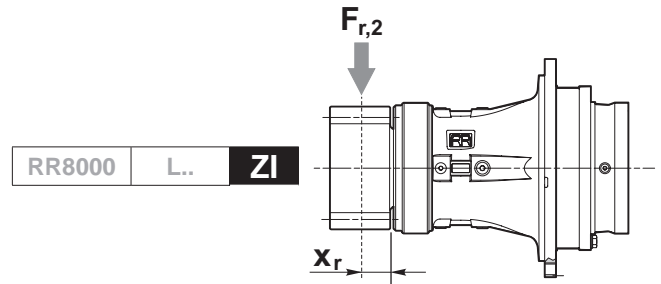



RR10000

IT EN DE FR ES PT

RR10000 L.. .. **i**



i	T ₂ [Nm]						n _{1max} [min ⁻¹]	T _{2max} [Nm]	P _t [kW]	
	n ₂ x h									
1/...	10000 (10 ⁴)	25000 (2.5 · 10 ⁴)	50000 (5 · 10 ⁴)	100000 (10 ⁵)	500000 (5 · 10 ⁵)	1000000 (10 ⁶)				
RR10000 L1	4.17	117240	108270	104430	96860	64730	52580	750	190000	94
	4.84	107220	98000	86760	82340	63600	51660	750	190000	94
	5.87	85830	72590	65160	62450	56580	50480	750	190000	94
RR10000 L2	17.42	117240	108270	104430	96860	64730	52580	1000	190000	59
	19.41	117240	108270	104430	96860	64730	52580	1000	190000	59
	22.10	117240	108270	104430	96860	64730	52580	1000	190000	59
	25.94	107660	98740	94630	90690	64730	52580	1000	190000	59
	30.09	107220	98000	86760	82340	63600	51660	1000	190000	59
	36.46	85830	72590	65160	62450	56580	50480	1000	190000	59
RR10000 L3	67.94	117240	108270	104430	96860	64730	52580	2000	190000	43
	76.86	117240	108270	104430	96860	64730	52580	2000	190000	43
	89.60	117240	108270	104430	96860	64730	52580	2000	190000	43
	99.82	117240	108270	104430	96860	64730	52580	2000	190000	43
	109.28	117240	108270	104430	96860	64730	52580	2000	190000	43
	121.75	117240	108270	104430	96860	64730	52580	2000	190000	43
	138.61	117240	108270	104430	96860	64730	52580	2000	190000	43
	162.70	107660	98740	94630	90690	64730	52580	2000	190000	43
	188.75	107220	98000	86760	82340	63600	51660	2000	190000	43
	228.69	85830	72590	65160	62450	56580	50480	2000	190000	43
RR10000 L4	231.01	117240	108270	104430	96860	64730	52580	3500	190000	34
	291.13	117240	108270	104430	96860	64730	52580	3500	190000	34
	339.72	117240	108270	104430	96860	64730	52580	3500	190000	34
	399.26	117240	108270	104430	96860	64730	52580	3500	190000	34
	454.57	117240	108270	104430	96860	64730	52580	3500	190000	34
	499.08	117240	108270	104430	96860	64730	52580	3500	190000	34
	565.43	117240	108270	104430	96860	64730	52580	3500	190000	34
	633.83	117240	108270	104430	96860	64730	52580	3500	190000	34
	706.12	117240	108270	104430	96860	64730	52580	3500	190000	34
	803.94	117240	108270	104430	96860	64730	52580	3500	190000	34
	852.22	117240	108270	104430	96860	64730	52580	3500	190000	34
	970.27	117240	108270	104430	96860	64730	52580	3500	190000	34
	1138.91	107660	98740	94630	90690	64730	52580	3500	190000	34
	1321.23	107220	98000	86760	82340	63600	51660	3500	190000	34
	1600.80	85830	72590	65160	62450	56580	50480	3500	190000	34



RR10000 A.. .. i



i	T ₂ [Nm]						n _{1max} [min ⁻¹]	T _{2max} [Nm]	P _t [kW]	
	n ₂ x h									
1/...	10000 (10 ⁴)	25000 (2.5 · 10 ⁴)	50000 (5 · 10 ⁴)	100000 (10 ⁵)	500000 (5 · 10 ⁵)	1000000 (10 ⁶)				
RR10000 A3 (A)	47.51	90690	68900	55960	45460	28050	22780	2500	190000	47
	52.93	97820	74310	60360	49030	30250	24570	2500	190000	47
	60.27	107120	81370	66090	53690	33130	26910	2500	190000	47
	70.74	107660	91030	73940	60060	37060	30100	2500	190000	47
	82.06	107220	98000	82040	66640	41120	33400	2500	190000	47
	99.43	85830	72590	65160	62450	47030	38200	2500	190000	47
	120.31	85830	72590	65160	62450	45280	36780	2500	190000	47
	141.78	85830	72590	65160	62450	42740	34710	2500	190000	47
(B)	48.24	107700	81810	66450	53980	33310	27050	2500	190000	50
	53.75	116160	88240	71670	58220	35920	29180	2500	190000	50
	61.19	117240	96630	78490	63750	39340	31950	2500	190000	50
	71.83	107660	98740	87800	71320	44010	35740	2500	190000	50
	83.33	107220	98000	86760	79130	48830	39660	2500	190000	50
	95.29	107220	98000	86760	80120	49440	40160	2500	190000	50
	106.11	107660	98740	88370	71780	44290	35980	2500	190000	50
	123.10	107220	98000	86760	79640	49140	39920	2500	190000	50
149.14	85830	72590	65160	62450	56210	45660	2500	190000	50	
(C)	42.88	117240	108270	104430	96860	64730	52580	2000	190000	58
	55.17	117240	108270	104430	96860	64730	52580	2000	190000	58
	66.52	117240	108270	104430	96860	64730	52580	2000	190000	58
	74.11	117240	108270	104430	96860	64730	52580	2000	190000	58
	84.37	117240	108270	104430	96860	64730	52580	2000	190000	58
	99.04	107660	98740	94630	90690	64730	52580	2000	190000	58
	114.89	107220	98000	86760	82340	63600	51660	2000	190000	58
	139.20	85830	72590	65160	62450	56580	50480	2000	190000	58
RR10000 A4 (A)	182.93	93880	71320	57930	47050	29030	23580	3500	190000	36
	206.93	102340	77750	63150	51290	31650	25710	3500	190000	36
	241.22	113940	86550	70300	57100	35240	28620	3500	190000	36
	268.74	117240	93350	75830	61590	38000	30870	3500	190000	36
	294.22	117240	99460	80790	65620	40490	32890	3500	190000	36
	327.78	117240	107280	87130	70780	43670	35470	3500	190000	36
	373.18	117240	108270	95420	77500	47820	38840	3500	190000	36
	438.04	107660	98740	94630	86700	53500	43450	3500	190000	36
	508.17	107220	98000	86760	82340	59360	48220	3500	190000	36
	554.44	117240	108270	90030	73130	45120	36650	3500	190000	36
	595.28	107220	98000	86760	82340	58460	47480	3500	190000	36
	650.81	107660	98740	94630	81810	50480	41000	3500	190000	36
	754.99	107220	98000	86760	82340	56010	45490	3500	190000	36
	914.74	85830	72590	65160	62450	56580	50480	3500	190000	36
	(B)	185.30	117240	108270	104430	96860	64730	52580	2500	190000
209.62		117240	108270	104430	96860	64730	52580	2500	190000	39
244.35		117240	108270	104430	96860	64730	52580	2500	190000	39
295.67		117240	108270	104430	96860	64730	52580	2500	190000	39
329.39		117240	108270	104430	96860	64730	52580	2500	190000	39
388.17		117240	108270	104430	96860	64730	52580	2500	190000	39
424.98		117240	108270	104430	96860	64730	52580	2500	190000	39
473.45		117240	108270	104430	96860	64730	52580	2500	190000	39
539.04		117240	108270	104430	96860	64730	52580	2500	190000	39
632.73		107660	98740	94630	90690	64730	52580	2500	190000	39
734.02		107220	98000	86760	82340	63600	51660	2500	190000	39
889.33		85830	72590	65160	62450	56580	50480	2500	190000	39



RR10000

IT EN DE FR ES PT

RR10000 L.. .. i

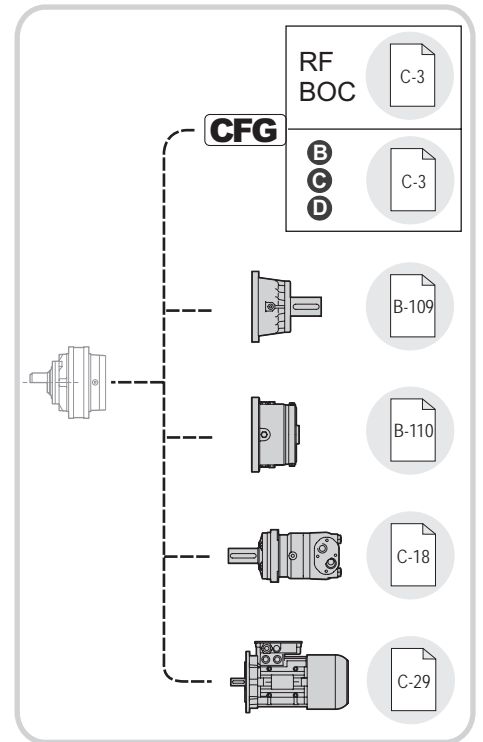
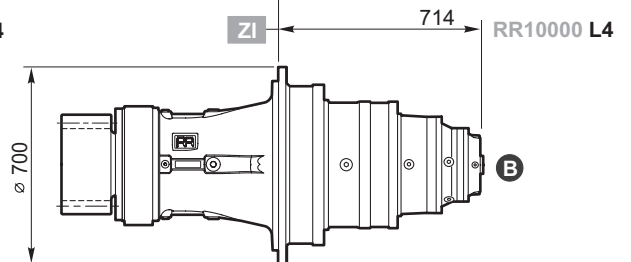
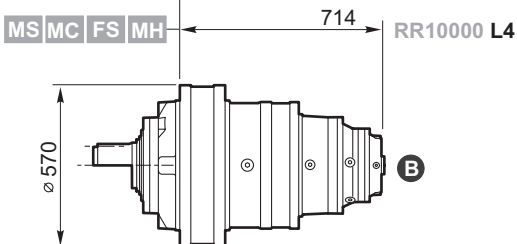
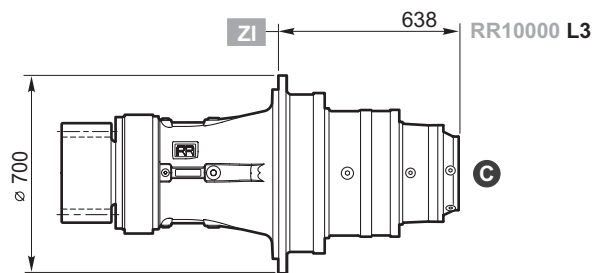
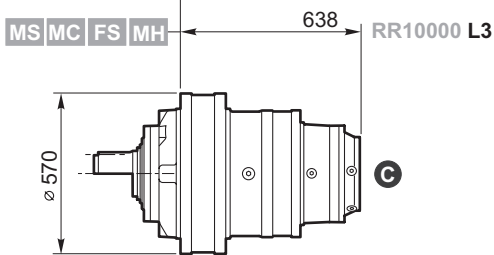
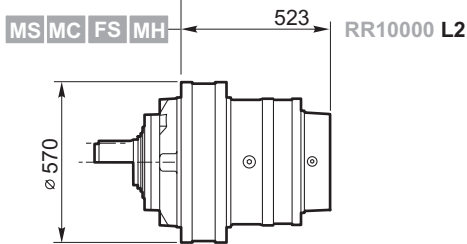
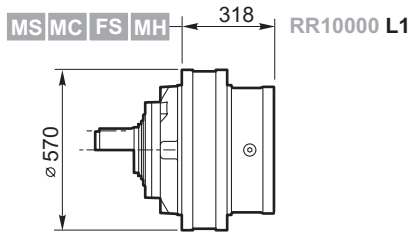

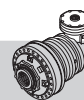

RR10000 A.. .. i

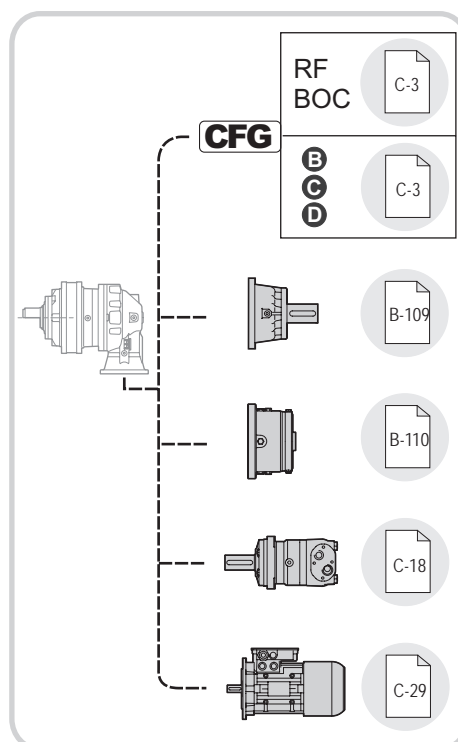
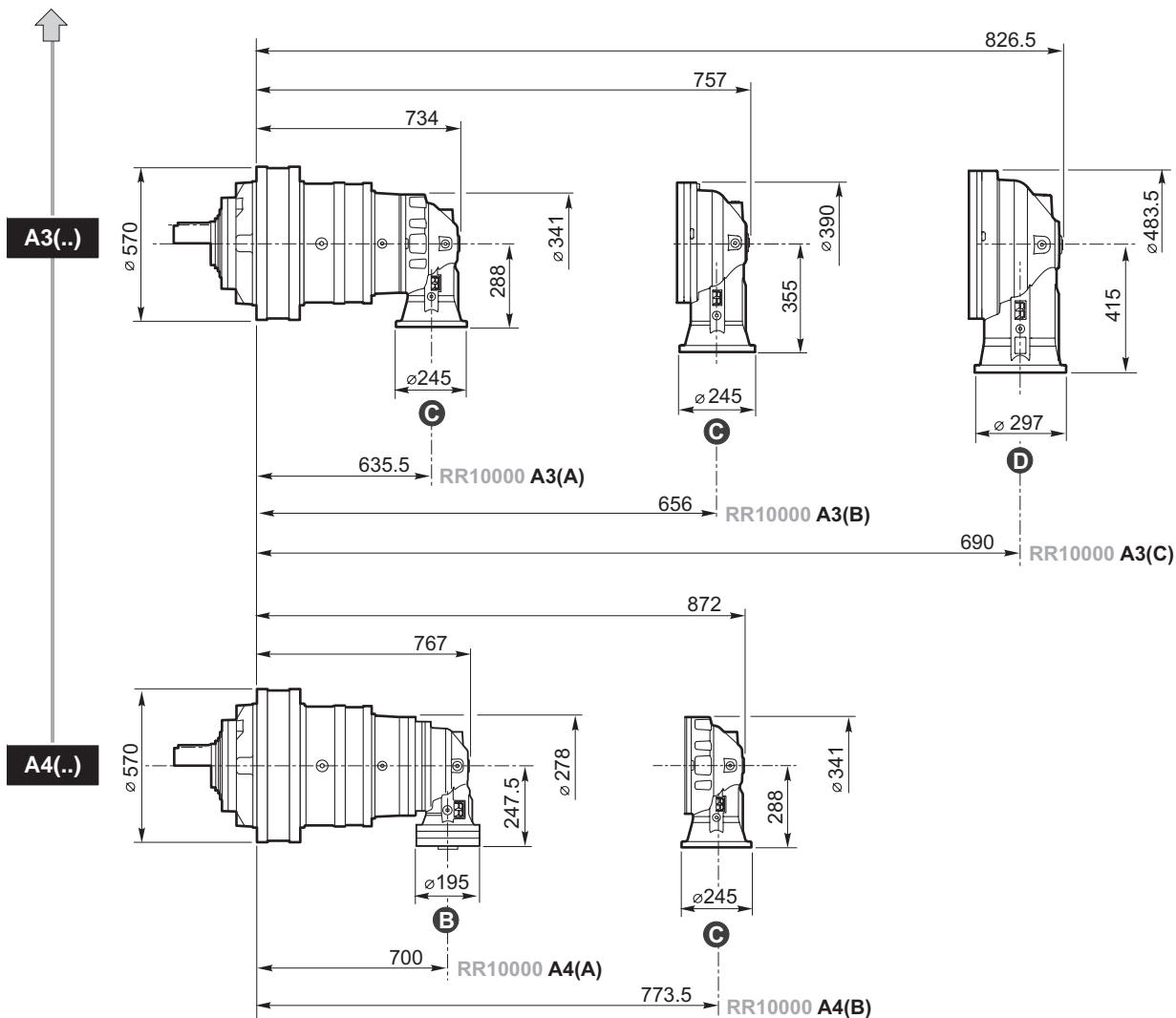

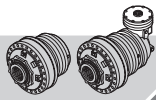

RR10000

IT EN DEFRES PT

RR10000	L..	MS	i
RR10000	A..		i

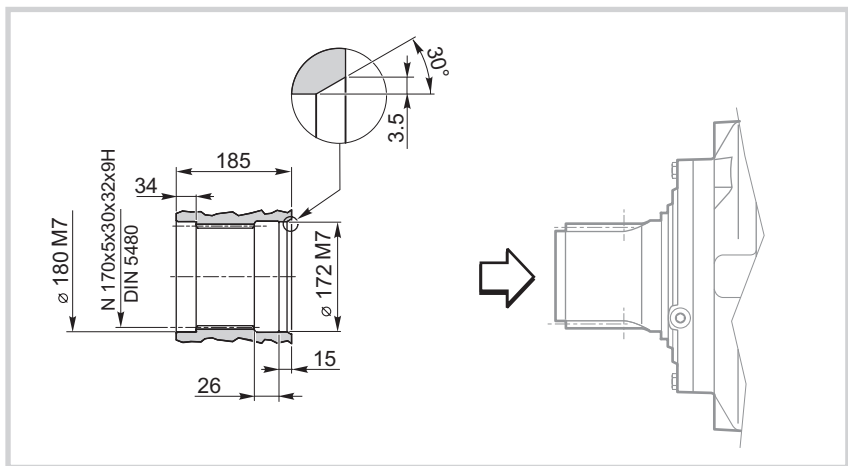
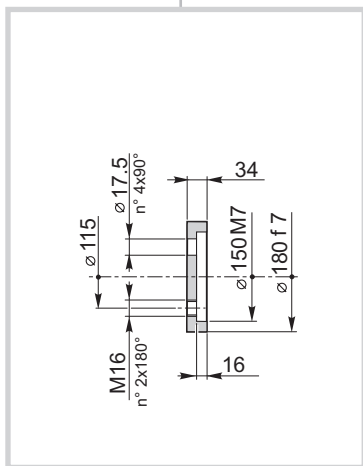
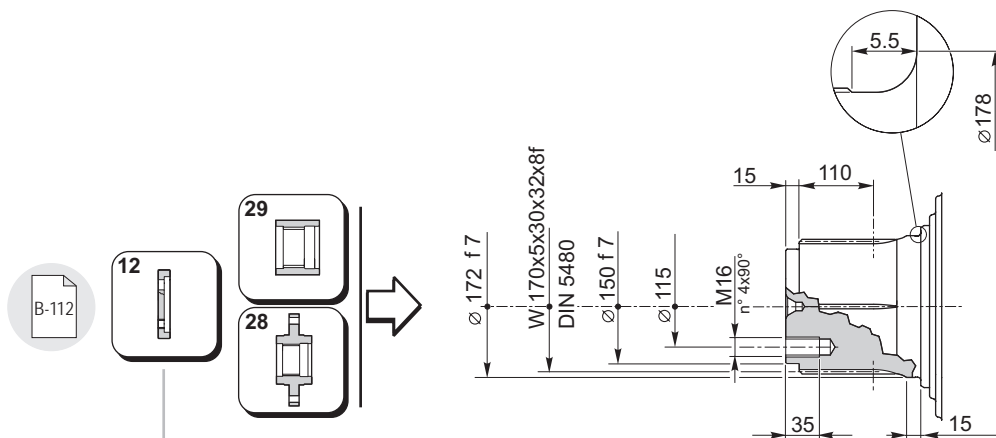
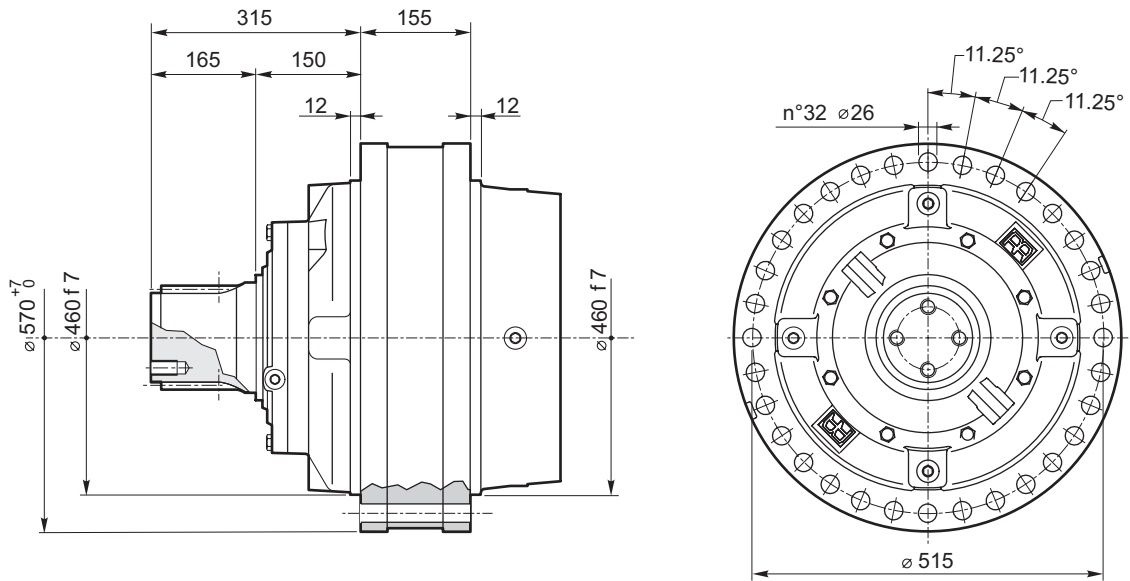

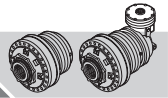

RR10000	L..	MC	i
RR10000	A..		i

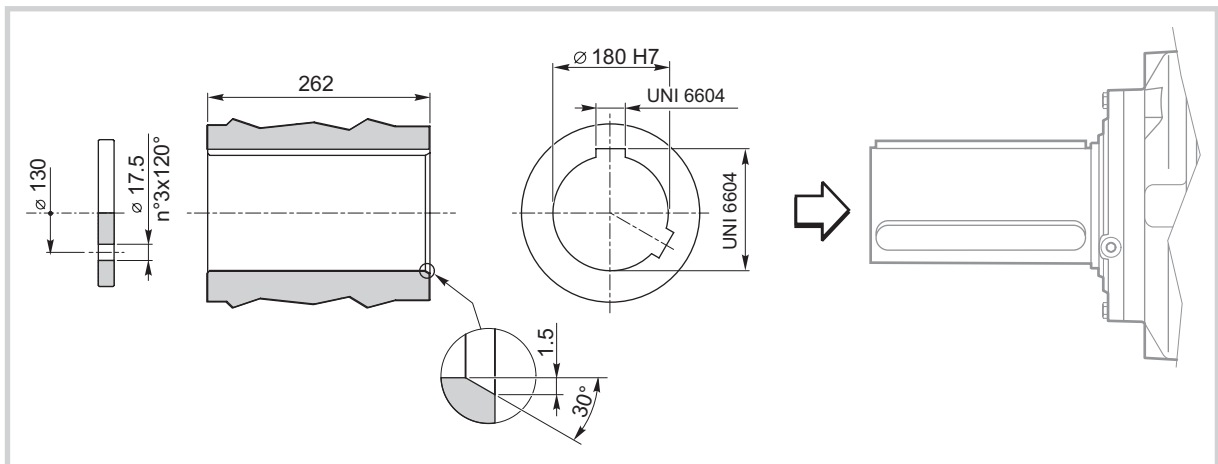
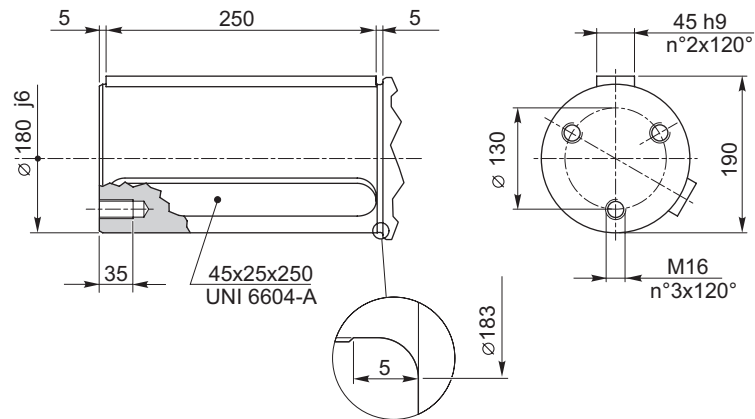
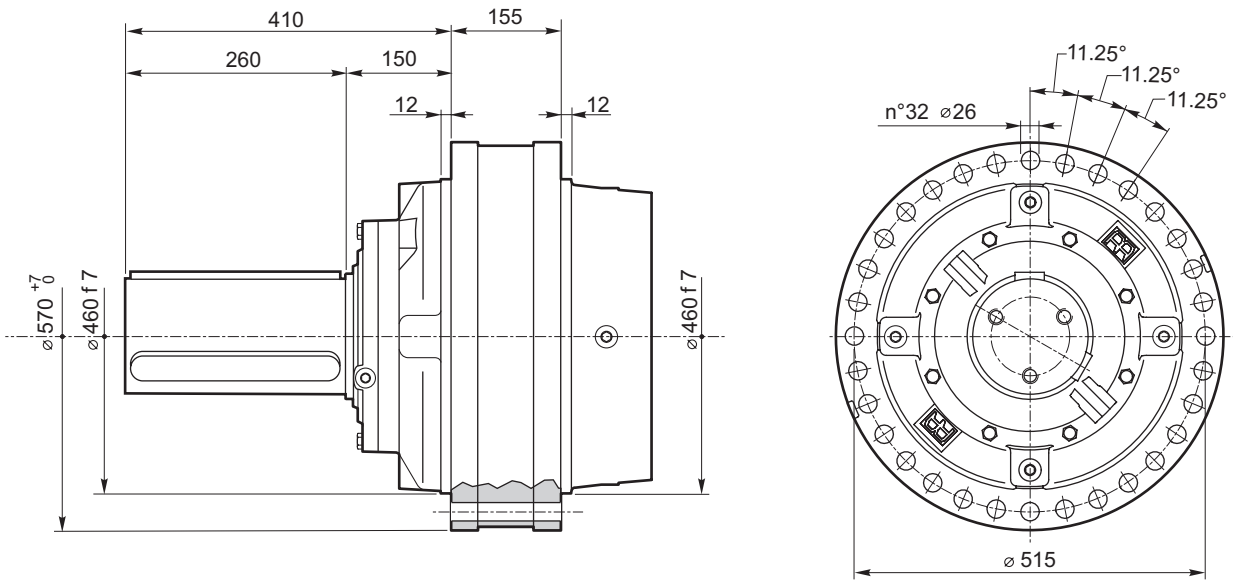

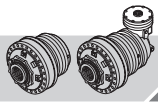

RR10000

IT EN DEFRES PT

RR10000	L..	FS	i
RR10000	A..		i

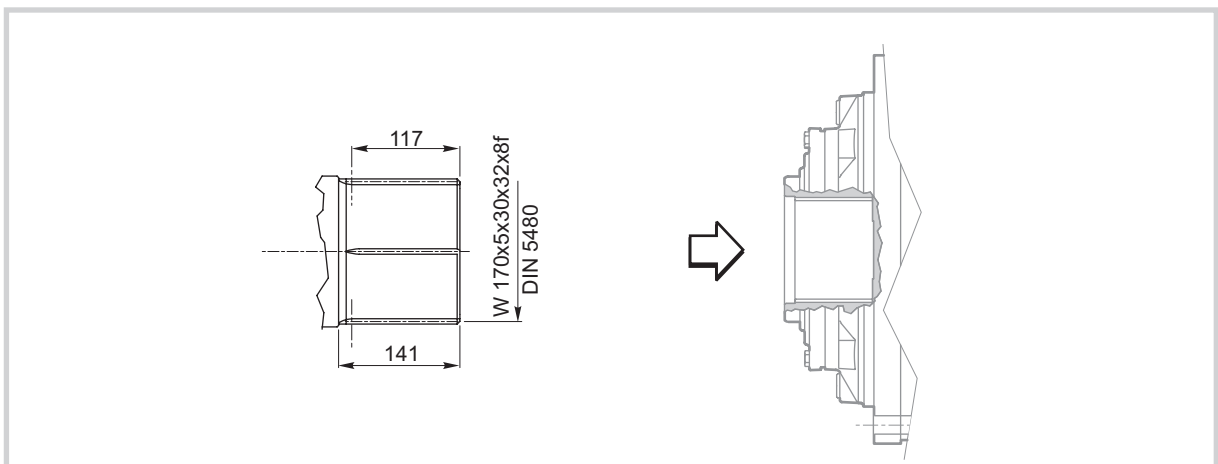
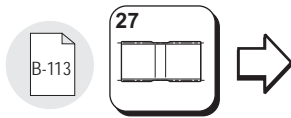
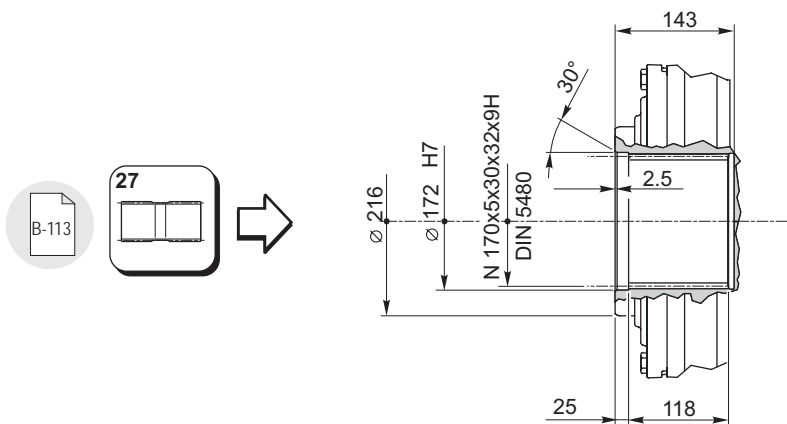
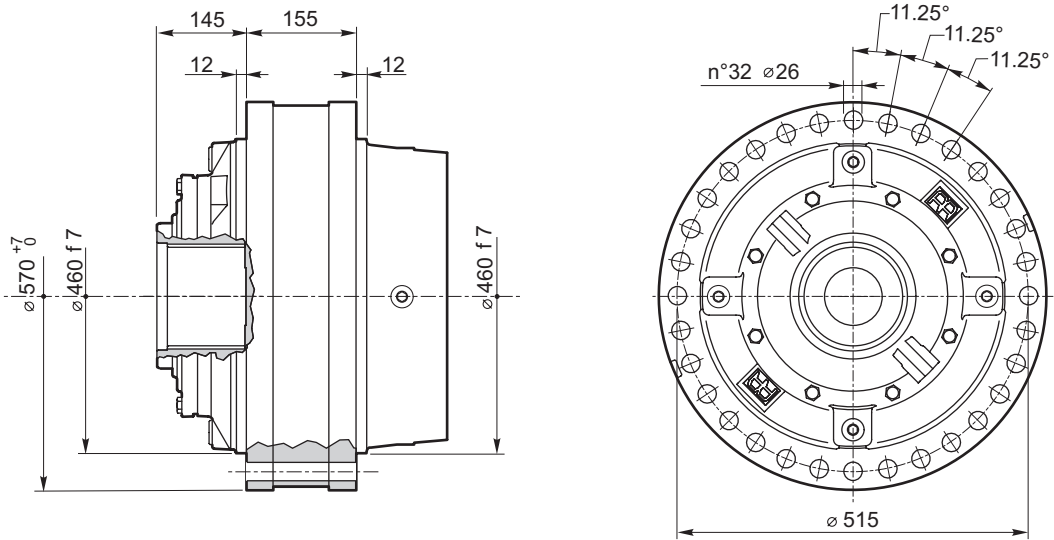

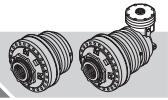

RR10000	L..	MH	i
RR10000	A..		i

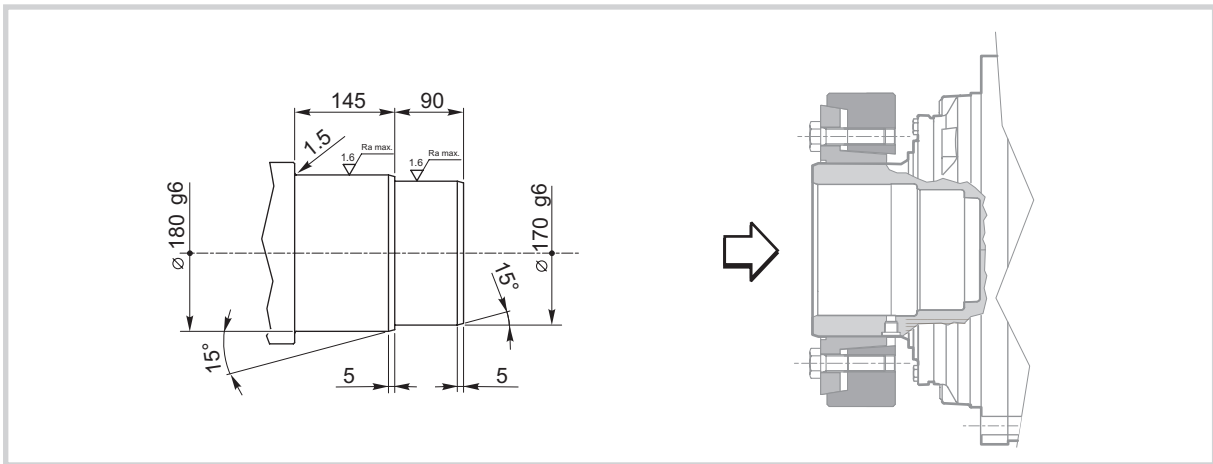
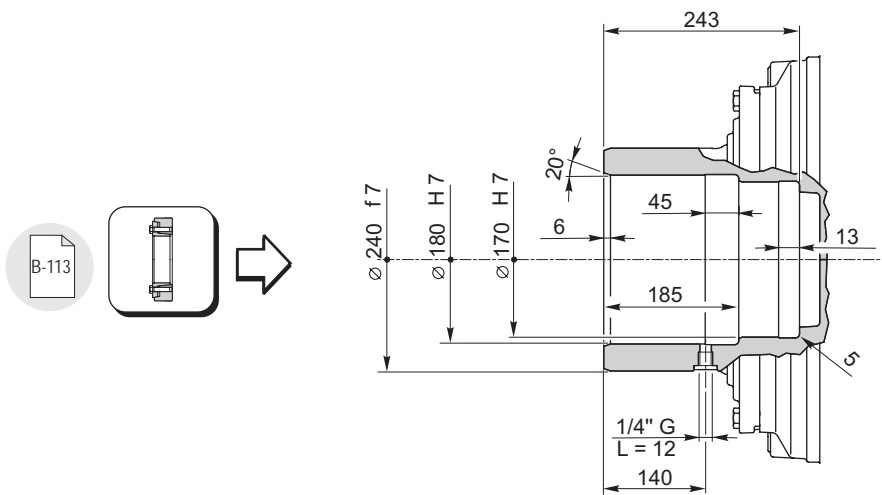
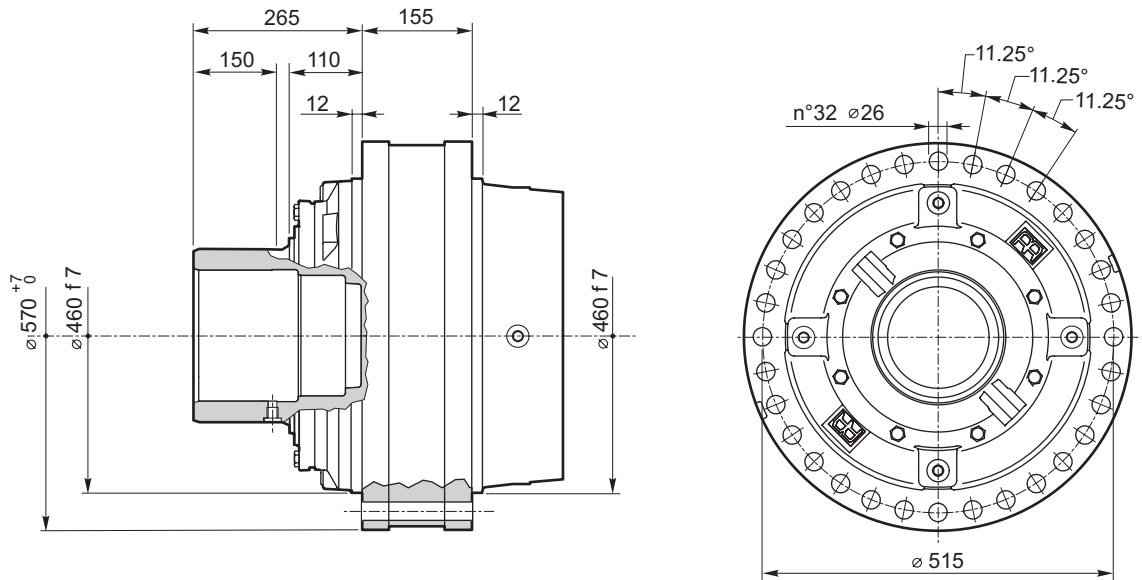



RR10000

IT EN DE FR ES PT

RR10000 L.. ZI i

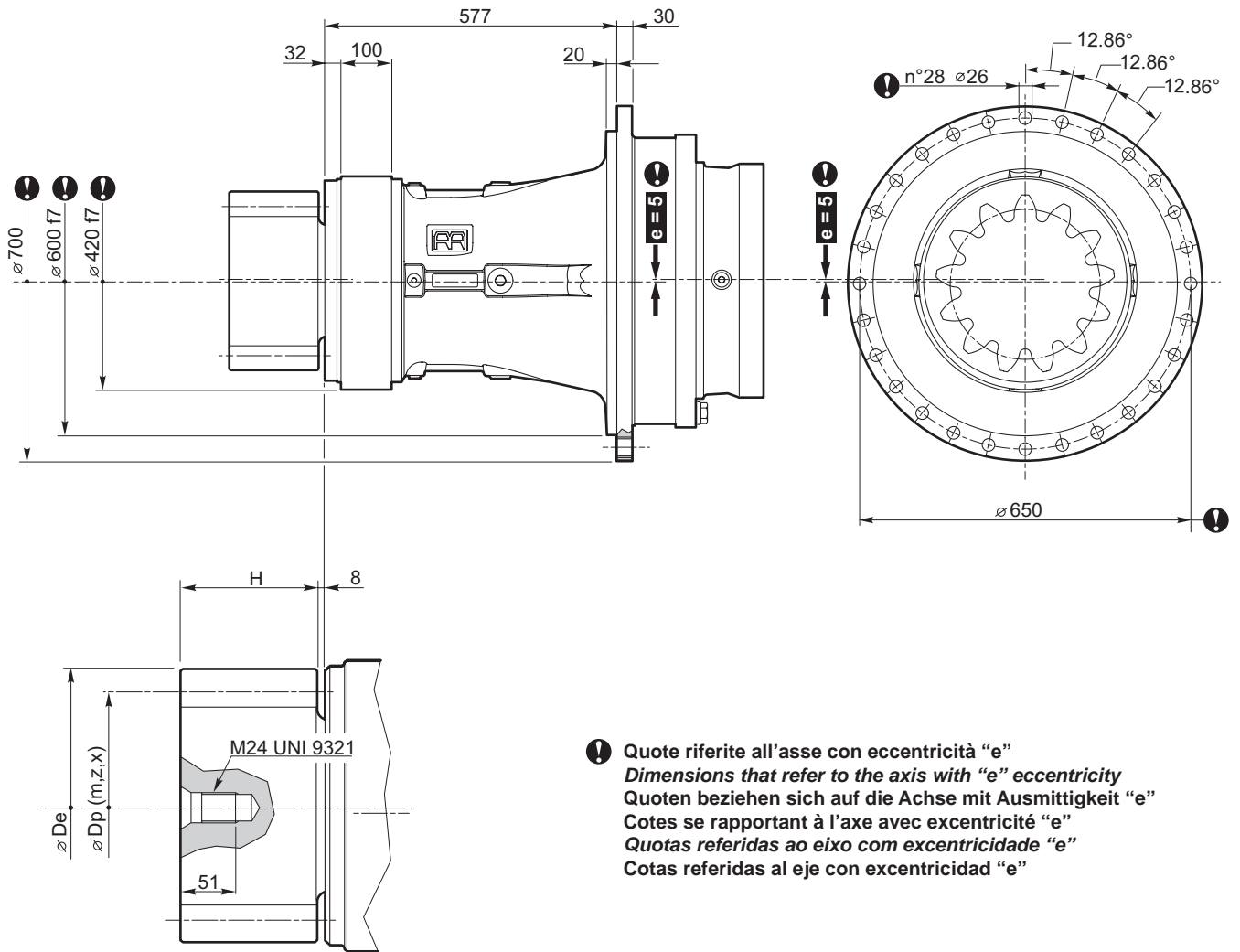

! Quote riferite all'asse con eccentricità "e"
 Dimensions that refer to the axis with "e" eccentricity
 Quoten beziehen sich auf die Achse mit Ausmittigkeit "e"
 Cotes se rapportant à l'axe avec excentricité "e"
 Quotas referidas ao eixo com excentricidade "e"
 Cotas referidas al eje con excentricidad "e"

	m	z	x	H	Dp	De	code
	20	15	0.5	200	300	360	03-639
	22	14	0.5	220	308	374	03-640
	24	14	0.5	220	336	408	03-641

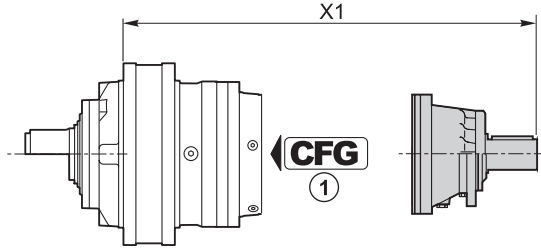
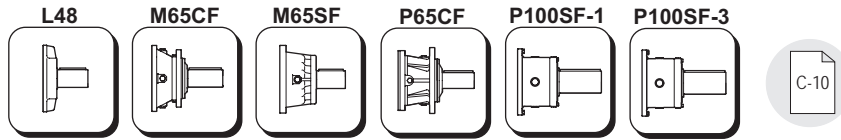
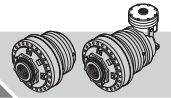

	CFG ①		code	X1
RR10000 L2	—	P100SF-3	154F3324	900
RR10000 L3	—	P65CF	154-2404	950
RR10000 L4	RF	M65SF	154B4249	898.5
	RF	M65CF	154-2407	921.5
	BOC	L48	154B3989	835.3

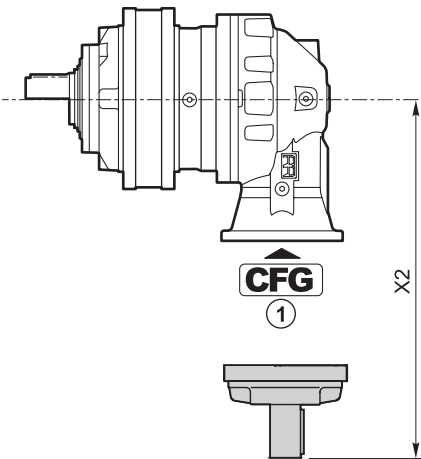

	CFG ①		code	X2
RR10000 A3(A)	—	P65CF	154-2404	600
RR10000 A3(B)	—	P65CF	154-2404	667
RR10000 A3(C)	—	P100SF-1	154F3322	791.5
RR10000 A4(A)	BOC	L48	154B3989	347.8
RR10000 A4(B)	—	P65CF	154-2404	600

CFG	
RF BOC	
B C D	

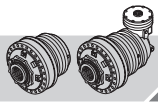

RR10000

IT EN DE FR ES PT

RF170-290

RF5/..

RFF5/..

RF2/..

C-12

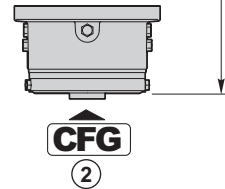
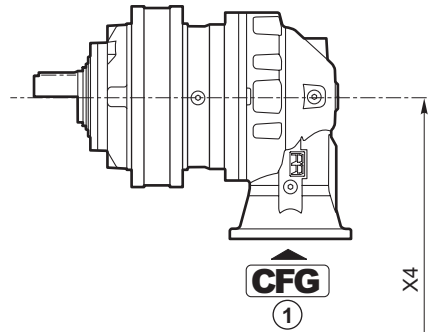
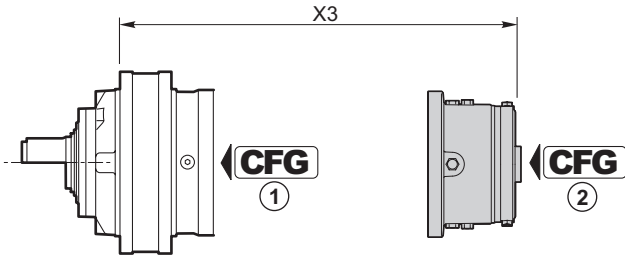

RF170-290	CFG ①	T _f [Nm]	CFG ②			
			C			
			code	X3	X4	
RR10000 L3	RF	1700	154B9766M2	835	—	
		2000	154B9767M2			
		2300	154B9768M2			
		2900	154B9769M2			
RR10000 A3(A)	—	1700	154B9766M3	—	485	
		2000	154B9767M3			
		2300	154B9768M3			
		2900	154B9769M3			
RR10000 A3(B)	—	1700	154B9766M3	—	552	
		2000	154B9767M3			
		2300	154B9768M3			
		2900	154B9769M3			
RR10000 A4(B)	—	1700	154B9766M3	—	485	
		2000	154B9767M3			
		2300	154B9768M3			
		2900	154B9769M3			

CFG	
RF BOC	C-3
B C D	C-3

RF5/..	CFG ①	T _f [Nm]	CFG ②						
			B			OMTS 12/24 z16	OMVS 10/20 z16		
			code	X3	X4	code	code	X3	X4
RR10000 L4	RF	210	154-2872	804.3	—	154-2879	154-2886	808	—
		290	154-2873			154-2880	154-2887		
		430	154-2874			154-2881	154-2888		
		650	154-2875			154-2882	154-2889		
		850	154-2876			154-2883	154-2890		
		1100	154-2877			154-2884	154-2891		
		1300	154-2878			154-2885	154-2892		



RFF5/..	CFG ①	T _f [Nm]	CFG ②						
			B			OMTS 12/24 z16	OMVS 10/20 z16		
			code	X3	X4	code	code	X3	X4
RR10000 A4(A)	RF	210	154-2893	—	316.6	154-5338	154-5345	—	320.5
		290	154-2894			154-5339	154-5346		
		430	154-2895			154-5340	154-5347		
		650	154-2896			154-5341	154-5348		
		850	154-2897			154-5342	154-5349		
		1100	154-2898			154-5343	154-5350		
		1300	154-2899			154-5344	154-5351		

CFG	
RF	
B C D	

RF2/..	CFG ①	T _f [Nm]	CFG ②								
			B			OMP/OMR SAE A 2B Ø 25	OMP/OMR SAE A 2B 1" 6B	OMP/OMR SAE A 4B Ø 25	OMP/OMR SAE A 4B 1" 6B		
			code	X3	X4	code	code	code	code	X3	X4
RR10000 L4	RF	70	154B9195	776.8	—	154B9195M10	—	154B9195M16	154B9195M17	776.8	—
		140	154B9196			154B9196M10	—	154B9196M16	154B9196M17		
		210	154B9197			154B9197M10	—	154B9197M16	154B9197M17		
		320	154B9198			154B9198M10	—	154B9198M16	154B9198M17		
		430	154B9199			154B9199M10	—	154B9199M16	154B9199M17		
		600	154B9200			154B9200M10	—	154B9200M16	154B9200M17		
RR10000 A4(A)	RF	70	154F2991	—	285.3						
		140	154F1890								
		210	154F2961								
		320	154B3591								
		430	154B3592								
		600	154F2992								

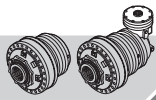

RR10000

IT EN DE FR ES PT

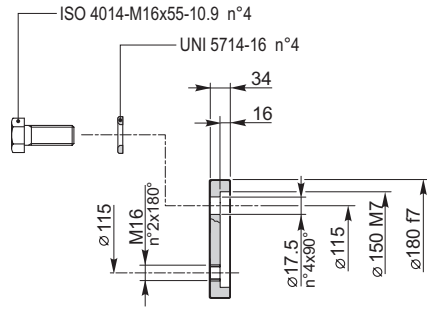
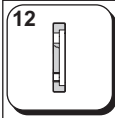

154F6034

Materiale / Material / Material / Matériau / Material / Material:
Acciaio / Steel / Stahl / Acier / Acero / Aço
 EN 10083-1-42CrMo4+QT (1.7225)

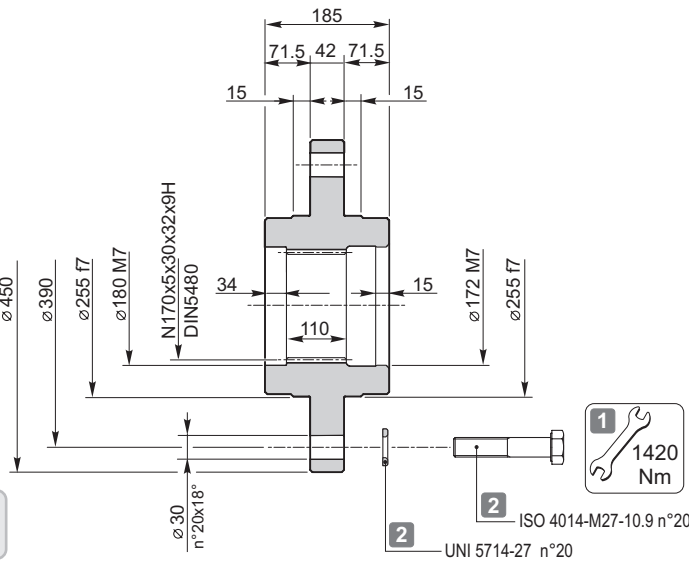
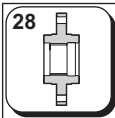

T_{2max} = 169000 Nm

154F6052

Materiale / Material / Material / Matériau / Material / Material:
Acciaio / Steel / Stahl / Acier / Acero / Aço
 EN 10083-1-C40 (1.1186)

Trattamento termico:

Tempra ad induzione secondo UNI 10932 su scanalato interno

Heat treatment:

Induction hardening according to UNI 10932 on internal spline

Wärmebehandlung:

Induktionshärtung nach UNI 10932 an interner Nut

Traitement thermique:

Trempe par induction conformément à la norme UNI 10932 sur cannelé interne

Tratamiento térmico:

Temple por inducción según UNI 10932 en acanalado interno

Tratamento térmico:

Tempera por indução segundo UNI 10932 sobre ranhuras internas

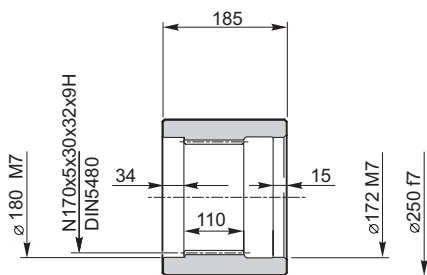

154F6060

Materiale / Material / Material / Matériau / Material / Material:
Acciaio / Steel / Stahl / Acier / Acero / Aço
 EN 10083-1-42CrMo4+QT (1.7225)

Trattamento termico:

Tempra ad induzione secondo UNI 10932 su scanalato interno

Heat treatment:

Induction hardening according to UNI 10932 on internal spline

Wärmebehandlung:

Induktionshärtung nach UNI 10932 an interner Nut

Traitement thermique:

Trempe par induction conformément à la norme UNI 10932 sur cannelé interne

Tratamiento térmico:

Temple por inducción según UNI 10932 en acanalado interno

Tratamento térmico:

Tempera por indução segundo UNI 10932 sobre ranhuras internas

1 Coefficiente d'attrito medio considerato: 0.14
 Average friction coefficient considered: 0.14
 Durchschnittlicher berücksichtigter Reibungskoeffizient: 0.14
 Coefficient de frottement moyen considéré: 0.14
 Coeficiente medio de fricción considerado: 0.14
 Coeficiente de atrito médio considerado: 0.14

2 Componenti non forniti da Reggiana Riduttori
 Components not supplied by Reggiana Riduttori
 Nicht von Reggiana Riduttori gelieferte Komponenten
 Parties pas fournies par Reggiana Riduttori
 Componentes no suministrados por Reggiana Riduttori
 Componentes não fornecidos por Reggiana Riduttori

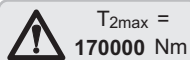
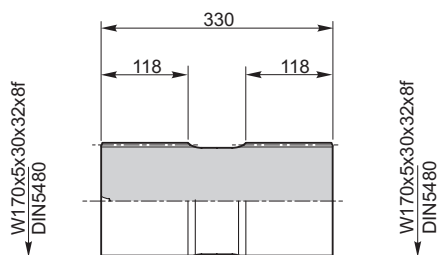
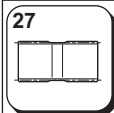
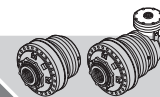

$T_{2max} =$
170000 Nm

154F6040

Materiale / Material / Material / Matériau / Material / Material:
Acciaio / Steel / Stahl / Acier / Acero / Aço
EN 10083-1-42CrMo4+QT (1.7225)

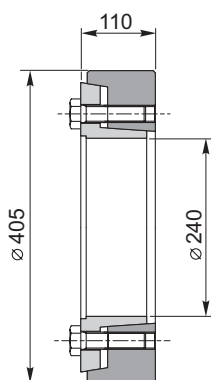
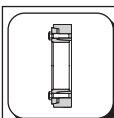

C-32

154F6068



$T_{2max} =$
xxxxxxx Nm

ATTENZIONE

Il valore di T_{2max} indicato costituisce una limitazione del valore relativo al riduttore, riportato nella tabella dei dati tecnici per ciascuna grandezza.

ATTENTION

Le valeur de T_{2max} indiquée représente une restriction de la valeur relative au réducteur et indiquée sur le tableau des caractéristiques techniques pour chaque grandeur.

ATENCIÓN

The T_{2max} value indicated is a limit of the reduction gear value, given in the technical data table for each size.

ATENÇÃO

El valor de T_{2max} indicado constituye una limitación del valor referente al reductor, indicado en la tabla de los datos técnicos para cada talla.

ACHTUNG!

Der angegebene Wert T_{2max} stellt eine Einschränkung vom entsprechenden Wert am Untersetzungsgetriebe dar, der in der Tabelle mit den technischen Daten für jede Größe angegeben ist.

ATENÇÃO

O valor T_{2max} indicado representa uma limitação do valor relativo ao redutor, indicado na tabela dos dados técnicos para cada grandeza.

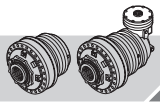

RR10000

IT EN DE FR ES PT

RR10000	L.. - A..	MS
		MC

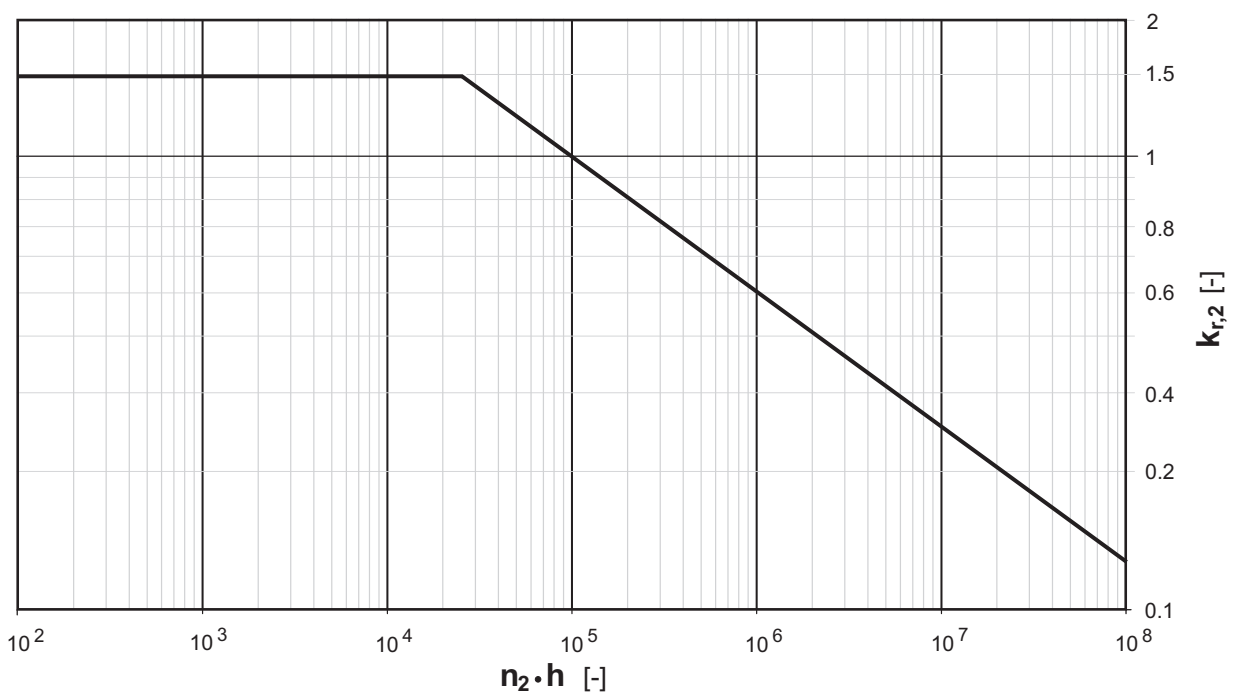
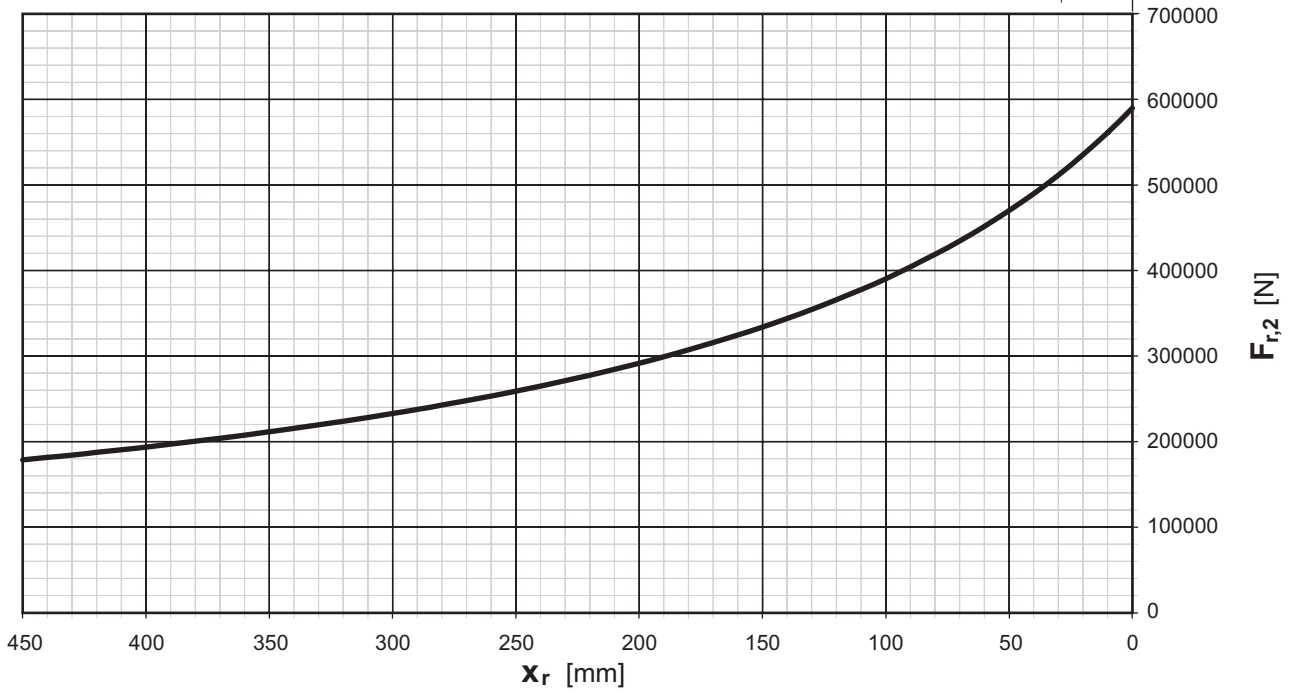
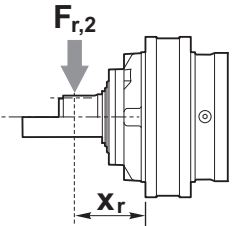

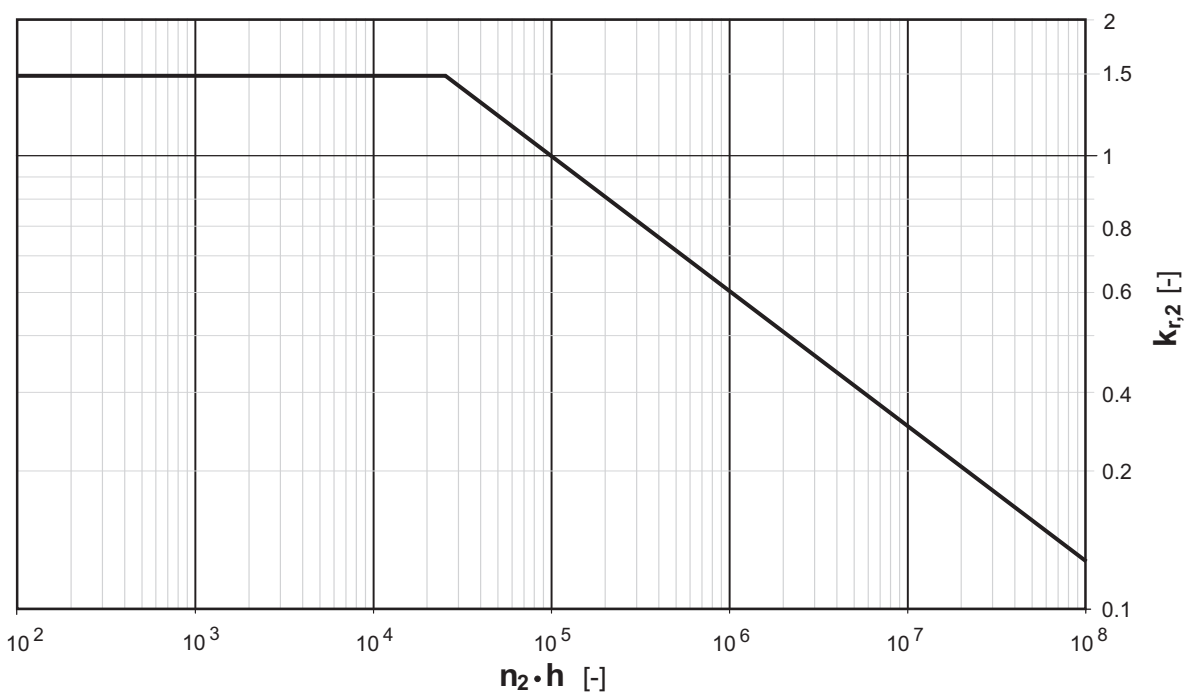
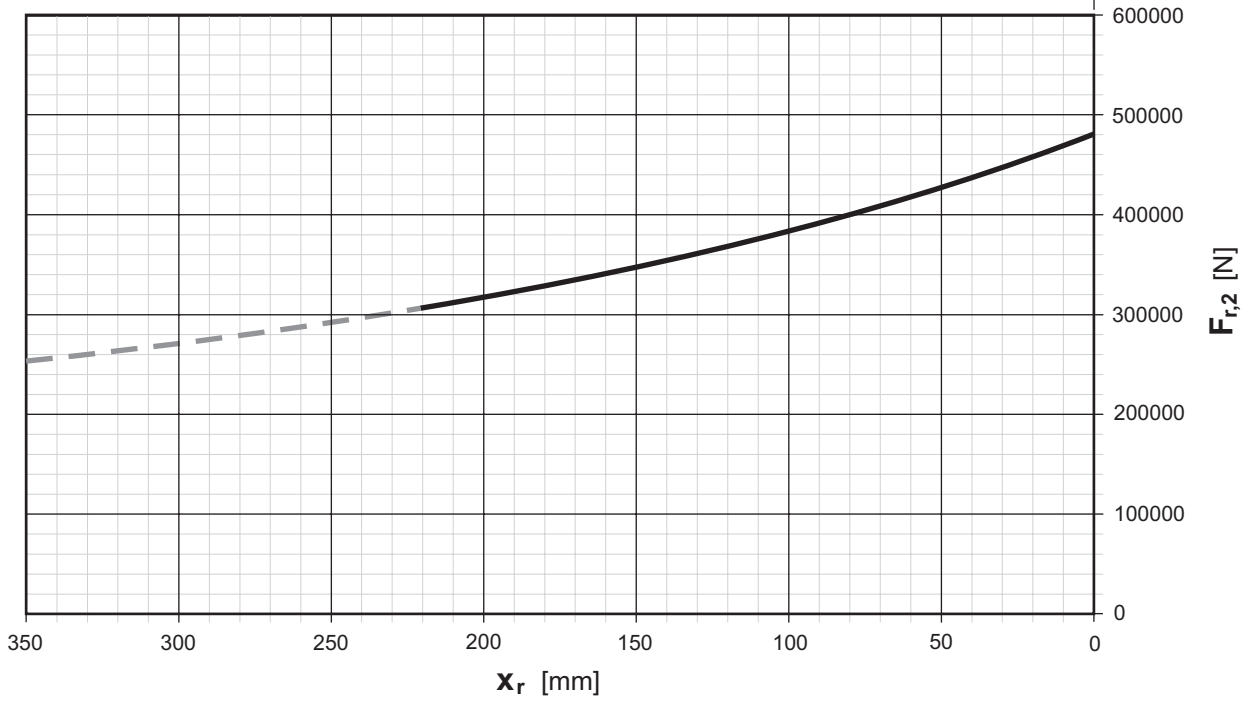
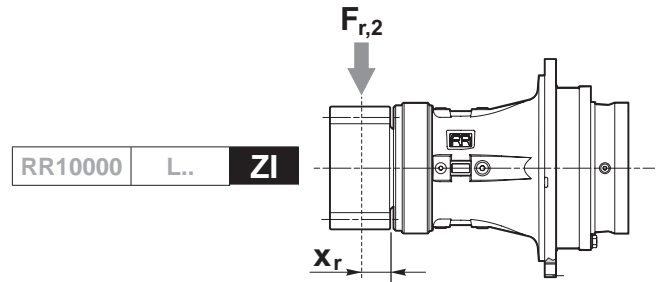



RR15000

IT EN DE FR ES PT

RR15000 L.. .. **i**



	i	T ₂ [Nm]						n _{1max} [min ⁻¹]	T _{2max} [Nm]	P _t [kW]
		n ₂ x h								
1/...		10000 (10 ⁴)	25000 (2.5 · 10 ⁴)	50000 (5 · 10 ⁴)	100000 (10 ⁵)	500000 (5 · 10 ⁵)	1000000 (10 ⁶)			
RR15000 L1	4.17	171460	158350	154320	143190	102530	83280	500	275000	120
	4.84	156880	143420	128720	122180	100780	81860	500	275000	120
	5.87	134630	114020	102440	98180	88950	80200	500	275000	120
RR15000 L2	17.42	171460	158350	154320	143190	94140	76460	1000	275000	72
	20.21	171460	158350	154320	143190	92260	74940	1000	275000	72
	23.45	156880	143420	128720	122180	100780	81860	1000	275000	72
	28.41	156880	143420	128720	122180	100270	81440	1000	275000	72
	34.42	134630	114020	102440	98180	88950	80200	1000	275000	72
RR15000 L3	67.94	171460	158350	154320	143190	94140	76460	2000	275000	51
	76.86	171460	158350	154320	143190	94140	76460	2000	275000	51
	89.16	171460	158350	154320	143190	92260	74940	2000	275000	51
	103.94	171460	158350	154320	143190	92260	74940	2000	275000	51
	126.78	151260	142990	137040	131330	92260	74940	2000	275000	51
	147.07	156880	143420	128720	122180	100780	81860	2000	275000	51
	178.19	156880	143420	128720	122180	100270	81440	2000	275000	51
	215.89	134630	114020	102440	98180	88950	80200	2000	275000	51
RR15000 L4	231.01	171460	158350	153940	125030	77150	62670	3500	275000	40
	271.78	171460	158350	149220	121210	74790	60750	3500	275000	40
	315.28	171460	158350	154320	134480	82980	67400	3500	275000	40
	356.66	171460	158350	154320	143190	90460	73480	3500	275000	40
	415.76	171460	158350	154320	143190	92260	74940	3500	275000	40
	457.16	171460	158350	154320	130300	80400	65310	3500	275000	40
	519.70	171460	158350	154320	143190	92260	74940	3500	275000	40
	602.85	171460	158350	154320	143190	92260	74940	3500	275000	40
	727.58	160870	152090	145770	140710	92260	74940	3500	275000	40
	887.43	151260	142990	137040	131330	92260	74940	3500	275000	40
	1033.50	156880	143420	128720	122180	100270	81440	3500	275000	40
	1247.33	156880	143420	128720	122180	100270	81440	3500	275000	40
	1511.25	134630	114020	102440	98180	88950	80200	3500	275000	40



RR15000 A.. .. i



	i	T ₂ [Nm]						n _{1max} [min ⁻¹]	T _{2max} [Nm]	P _t [kW]
		n ₂ x h								
		10000 (10 ⁴)	25000 (2.5 · 10 ⁴)	50000 (5 · 10 ⁴)	100000 (10 ⁵)	500000 (5 · 10 ⁵)	1000000 (10 ⁶)			
RR15000 A3 (A)	47.51	90690	68900	55960	45460	28050	22780	2500	249730	55
	55.12	100630	76440	62090	50430	31120	25280	2500	275000	55
	63.94	111650	84820	68890	55960	34530	28050	2500	275000	55
	77.47	127710	97010	78800	64010	39490	32080	2500	275000	55
	93.87	134630	110970	90130	73210	45170	36690	2500	275000	55
	113.58	134630	106830	86780	70480	43490	35330	2500	275000	55
	133.85	132740	100840	81910	66530	41050	33340	2500	275000	55
(B)	48.24	107700	81810	66450	53980	33310	27050	2500	275000	59
	55.97	119490	90770	73730	59890	36950	30020	2500	275000	59
	64.93	132580	100720	81810	66450	41000	33300	2500	275000	59
	78.67	151650	115200	93570	76000	46900	38090	2500	275000	59
	95.31	134630	114020	102440	86930	53640	43570	2500	275000	59
	108.99	134630	114020	102440	88030	54320	44120	2500	275000	59
	140.80	134630	114020	102440	87500	53990	43850	2500	275000	59
(C)	42.88	171460	158350	140770	114340	70550	57310	2000	275000	67
	49.75	171460	158350	154320	126870	78280	63580	2000	275000	67
	57.71	156880	143420	128720	122180	86860	70550	2000	275000	67
	69.92	156880	143420	128720	122180	99350	80690	2000	275000	67
	74.25	156880	143420	128720	122180	86780	70490	2000	275000	67
	89.96	156880	143420	128720	122180	99260	80620	2000	275000	67
	108.46	156880	143420	128720	122180	97980	79590	2000	275000	67
	131.41	134630	114020	102440	98180	88950	80200	2000	275000	67
RR15000 A4 (A)	182.93	93880	71320	57930	47050	29030	23580	3500	275000	42
	206.93	102340	77750	63150	51290	31650	25710	3500	275000	42
	240.06	113550	86260	70070	56910	35120	28520	3500	275000	42
	279.84	126420	96040	78000	63360	39100	31760	3500	275000	42
	341.32	145270	110360	89640	72810	44930	36490	3500	275000	42
	395.96	156880	122450	99460	80790	49850	40490	3500	275000	42
	479.74	156880	140060	113760	92400	57020	46310	3500	275000	42
	581.25	134630	114020	102440	98180	65210	52970	3500	275000	42
	680.89	134630	114020	102440	98180	64230	52170	3500	275000	42
	712.76	156880	132140	107340	87180	53790	43700	3500	275000	42
	863.57	134630	114020	102440	98180	61530	49980	3500	275000	42
(B)	185.30	171460	158350	141460	114900	70900	57590	2500	275000	46
	209.62	171460	158350	154210	125260	77290	62780	2500	275000	46
	243.17	171460	158350	154320	138980	85760	69660	2500	275000	46
	283.47	171460	158350	154320	143190	92260	74940	2500	275000	46
	343.00	171460	158350	154320	143190	91920	74660	2500	275000	46
	418.36	151260	142990	137040	131330	92260	74940	2500	275000	46
	493.01	151260	142990	137040	131330	92260	74940	2500	275000	46
	588.03	156880	143420	128720	122180	100270	81440	2500	275000	46
	692.96	156880	143420	128720	122180	100270	81440	2500	275000	46
	839.59	134630	114020	102440	98180	88950	80200	2500	275000	46
(C)	188.15	171460	158350	154320	136440	84190	68380	2500	275000	47
	212.84	171460	158350	154320	143190	91780	74550	2500	275000	47
	246.92	171460	158350	154320	143190	92260	74940	2500	275000	47
	282.35	171460	158350	154320	143190	92260	74940	2500	275000	47
	329.14	171460	158350	154320	143190	92260	74940	2500	275000	47
	364.76	171460	158350	154320	143190	92260	74940	2500	275000	47
	425.21	171460	158350	154320	143190	92260	74940	2500	275000	47
	518.63	151260	142990	137040	131330	92260	74940	2500	275000	47
	601.65	156880	143420	128720	122180	100780	81860	2500	275000	47
	728.96	156880	143420	128720	122180	100270	81440	2500	275000	47
	883.20	134630	114020	102440	98180	88950	80200	2500	275000	47



RR15000

IT EN DE FR ES PT

RR15000 L.. .. i

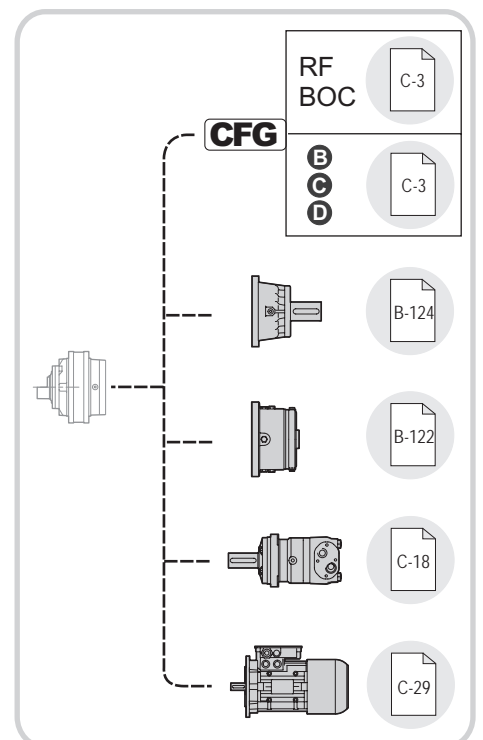
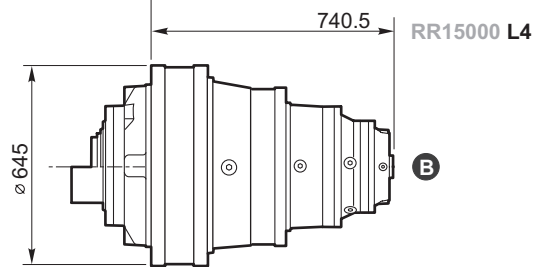
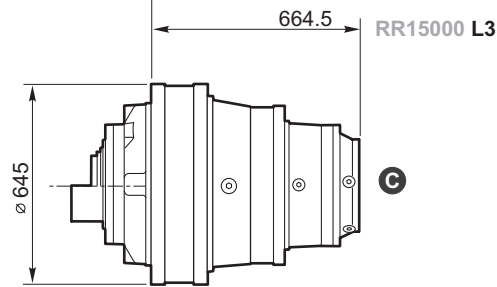
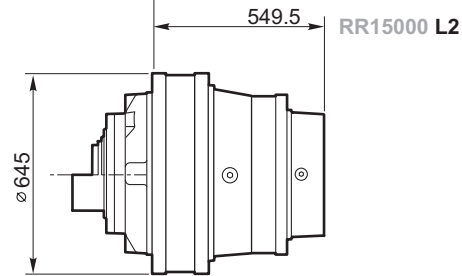
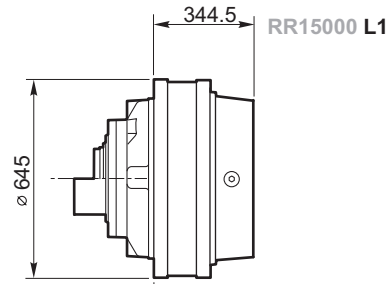

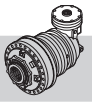

RR15000 A.. .. i

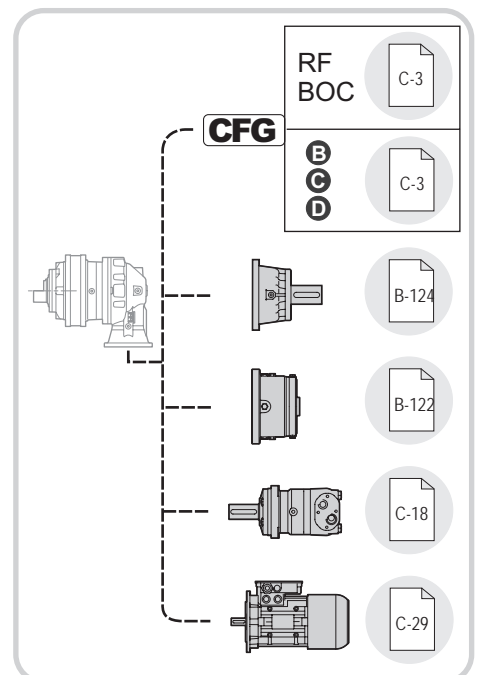
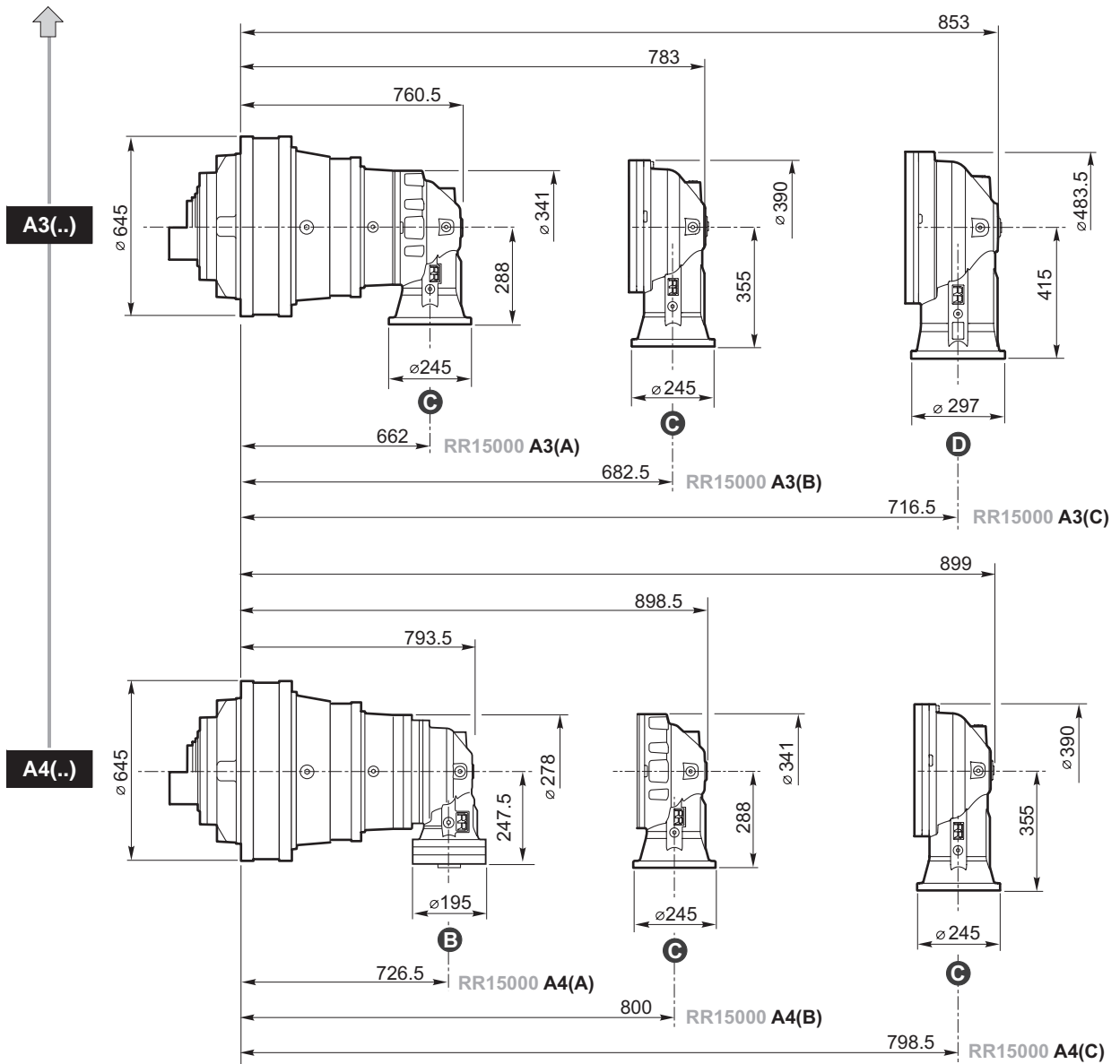

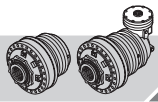

RR15000

IT EN DEFRES PT

RR15000	L..	FS	i
RR15000	A..		i

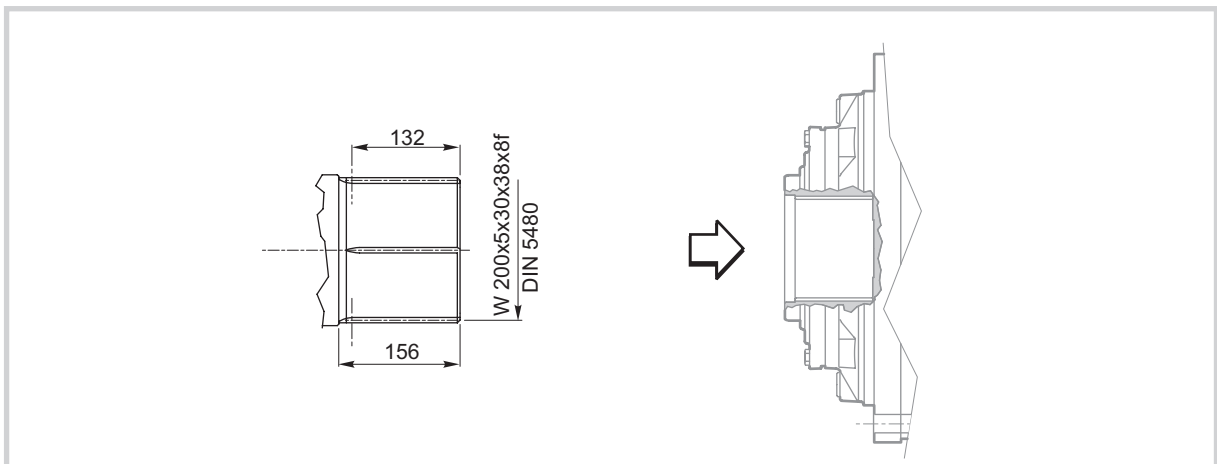
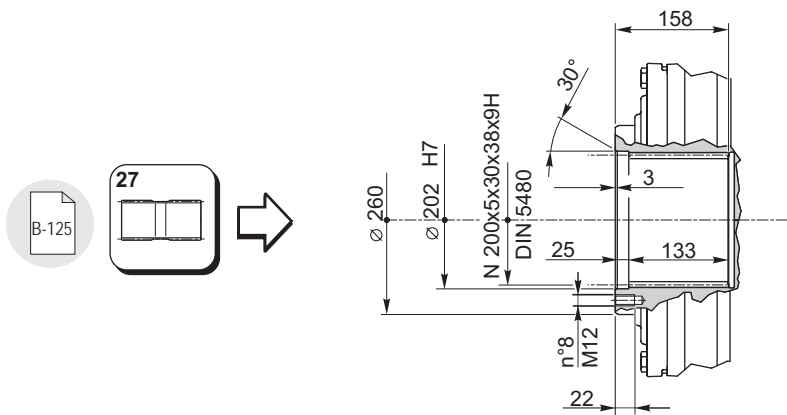
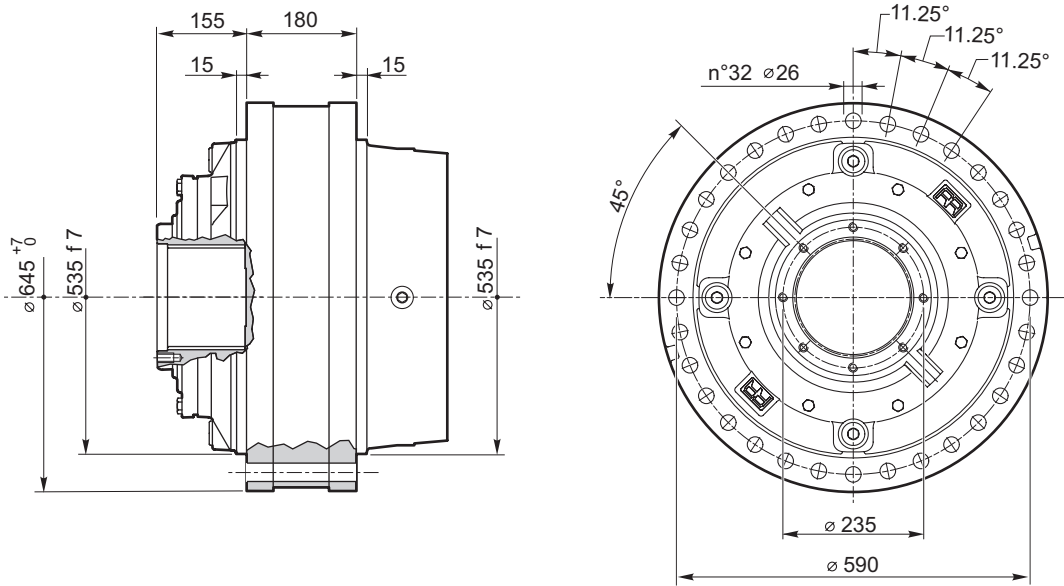

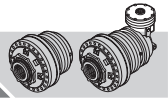

RR15000	L..	MH	i
RR15000	A..		i

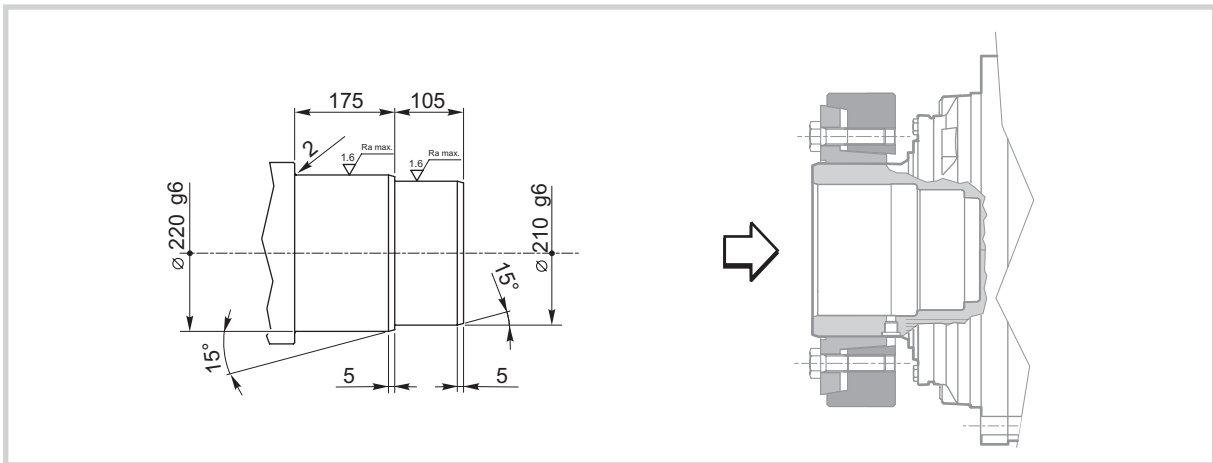
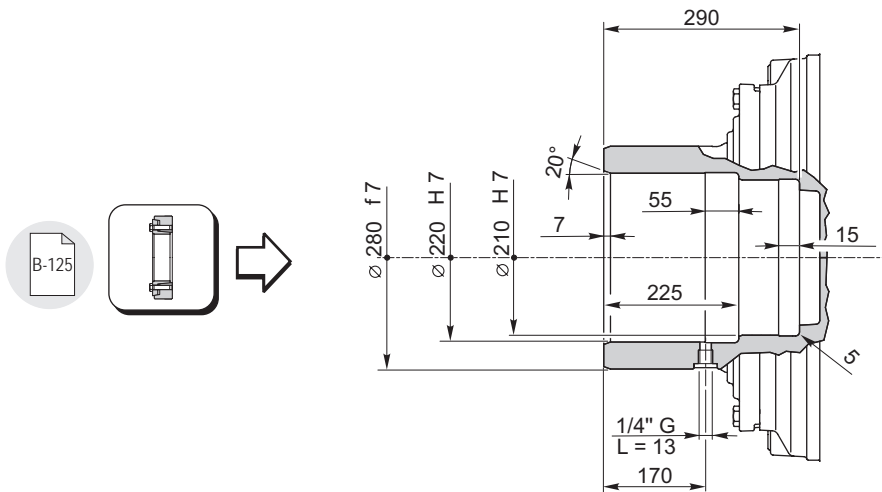
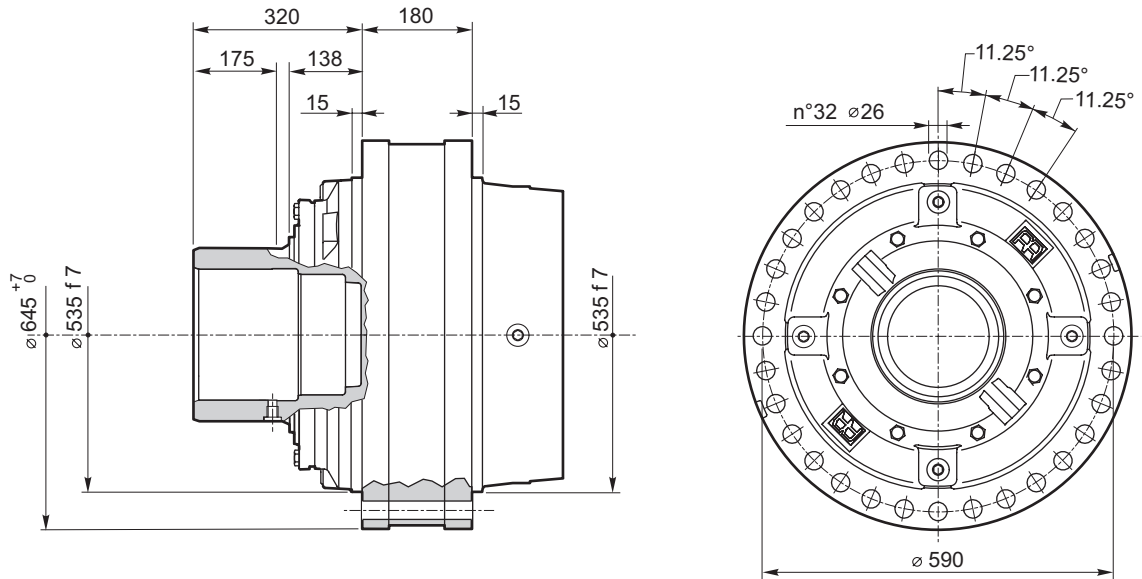

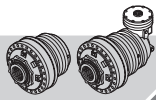

RR15000

IT EN DE FR ES PT

RF170-290

RF5/..

RFF5/..

RF2/..

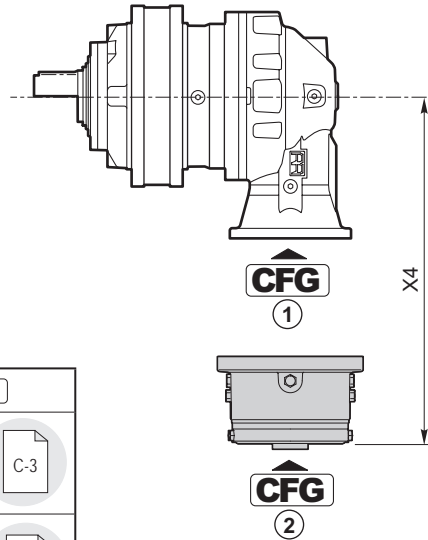
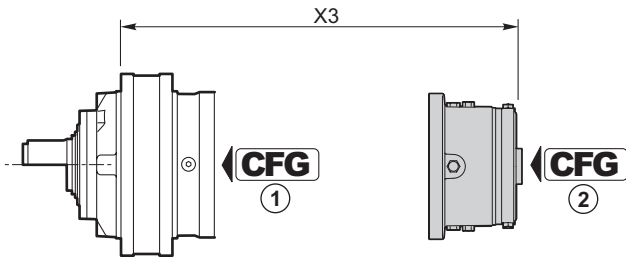

RF170-290	CFG ①	T _f [Nm]	CFG ②		
			C		
			code	X3	X4
RR15000 L3	RF	1700	154B9766M2	861.5	—
		2000	154B9767M2		
		2300	154B9768M2		
		2900	154B9769M2		
RR15000 A3(A)	—	1700	154B9766M3	—	485
		2000	154B9767M3		
		2300	154B9768M3		
		2900	154B9769M3		
RR15000 A3(B)	—	1700	154B9766M3	—	552
		2000	154B9767M3		
		2300	154B9768M3		
		2900	154B9769M3		
RR15000 A4(B)	—	1700	154B9766M3	—	485
		2000	154B9767M3		
		2300	154B9768M3		
		2900	154B9769M3		
RR15000 A4(C)	—	1700	154B9766M3	—	552
		2000	154B9767M3		
		2300	154B9768M3		
		2900	154B9769M3		

CFG	
RF BOC	C-3
B C D	C-3

RF5/..	CFG ①	T _f [Nm]	CFG ②						
			B			OMTS 12/24 z16	OMVS 10/20 z16	X3	X4
			code	X3	X4	code	code		
RR15000 L4	RF	210	154-2872	830.8	—	154-2879	154-2886	834.5	—
		290	154-2873			154-2880	154-2887		
		430	154-2874			154-2881	154-2888		
		650	154-2875			154-2882	154-2889		
		850	154-2876			154-2883	154-2890		
		1100	154-2877			154-2884	154-2891		
		1300	154-2878			154-2885	154-2892		

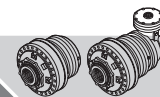

RFF5/..	CFG ①	T _f [Nm]	CFG ②						
			B			OMTS 12/24 z16	OMVS 10/20 z16	X3	X4
			code	X3	X4	code	code		
RR15000 A4(A)	RF	210	154-2893	—	316.6	154-5338	154-5345	—	320.5
		290	154-2894			154-5339	154-5346		
		430	154-2895			154-5340	154-5347		
		650	154-2896	154-5341	154-5348				
		850	154-2897	154-5342	154-5349				
		1100	154-2898	154-5343	154-5350				
		1300	154-2899	154-5344	154-5351				

CFG	
RF	
B C D	

RF2/..	CFG ①	T _f [Nm]	CFG ②								
			B			OMP/OMR SAE A 2B Ø 25	OMP/OMR SAE A 2B 1" 6B	OMP/OMR SAE A 4B Ø 25	OMP/OMR SAE A 4B 1" 6B	X3	X4
			code	X3	X4	code	code	code	code		
RR15000 L4	RF	70	154B9195	803.3	—	154B9195M10	—	154B9195M16	154B9195M17	793.3	—
		140	154B9196			154B9196M10	—	154B9196M16	154B9196M17		
		210	154B9197			154B9197M10	—	154B9197M16	154B9197M17		
		320	154B9198			154B9198M10	—	154B9198M16	154B9198M17		
		430	154B9199			154B9199M10	—	154B9199M16	154B9199M17		
		600	154B9200			154B9200M10	—	154B9200M16	154B9200M17		
RR15000 A4(A)	RF	70	154F2991	—	285.3						
		140	154F1890								
		210	154F2961								
		320	154B3591								
		430	154B3592								
		600	154F2992								

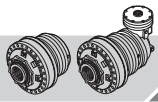

RR15000

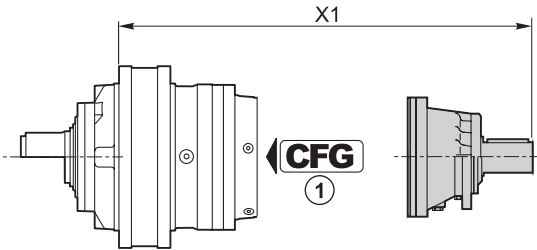
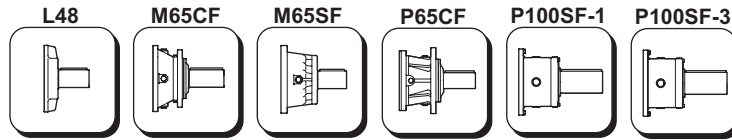

IT EN DE FR ES PT

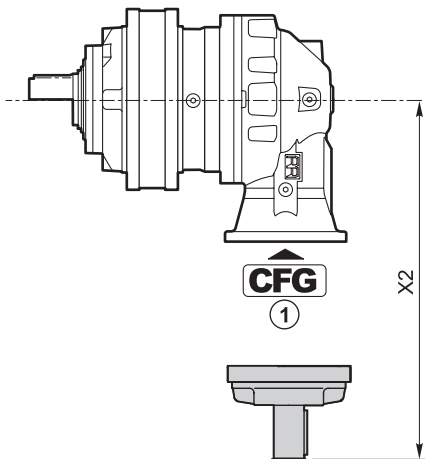

	CFG ①		code	X1
RR15000 L2	—	P100SF-3	154F3324	926.5
RR15000 L3	—	P65CF	154-2404	976.5
RR15000 L4	RF	M65SF	154B4249	925
	RF	M65CF	154-2407	948
	BOC	L48	154B3989	861.8



	CFG ①		code	X2
RR15000 A3(A)	—	P65CF	154-2404	600
RR15000 A3(B)	—	P65CF	154-2404	667
RR15000 A3(C)	—	P100SF-1	154F3322	791.5
RR15000 A4(A)	BOC	L48	154B3989	347.8
RR15000 A4(B)	—	P65CF	154-2404	600
RR15000 A4(C)	—	P65CF	154-2404	667

CFG	
RF BOC	
B C D	

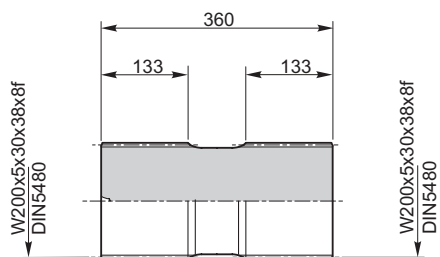
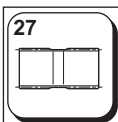
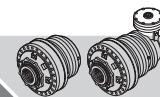

Materiale / Material / Material / Matériau / Material / Material:
 Acciaio / Steel / Stahl / Acier / Acero / Aço
 EN 10083-1-42CrMo4+QT (1.7225)

154F6041

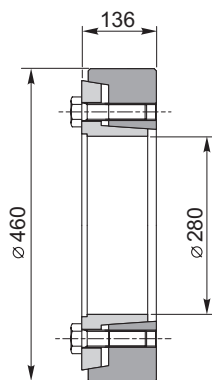
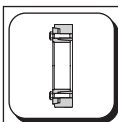

154F6069



RR20000

IT EN DE FR ES PT

RR20000 L.. .. **i**



	i	T ₂ [Nm]						n _{1max} [min ⁻¹]	T _{2max} [Nm]	P _t [kW]
		n ₂ x h								
1/...		10000 (10 ⁴)	25000 (2.5 · 10 ⁴)	50000 (5 · 10 ⁴)	100000 (10 ⁵)	500000 (5 · 10 ⁵)	1000000 (10 ⁶)			
RR20000 L1	4.17	245740	226780	223510	207490	143390	116470	500	395000	149
	4.84	226390	206800	187290	177790	140930	114470	500	395000	149
	5.87	195130	165490	148810	142610	129200	112140	500	395000	149
RR20000 L2	17.42	245740	226780	223510	183660	113320	92050	1000	395000	89
	20.21	245740	226780	222230	180510	111380	90470	1000	395000	89
	23.45	226390	206800	187290	177790	123580	100380	1000	395000	89
	28.41	225340	206800	187290	177790	121080	98350	1000	395000	89
	34.42	195130	165490	148810	142610	129200	112140	1000	395000	89
RR20000 L3	69.69	245740	226780	223510	183660	113320	92050	2000	395000	65
	81.98	245740	226780	223510	183660	113320	92050	2000	395000	65
	95.11	245740	226780	222230	180510	111380	90470	2000	395000	65
	118.15	245740	226780	222230	180510	111380	90470	2000	395000	65
	137.07	226390	206800	187290	177790	123580	100380	2000	395000	65
	166.07	225340	206800	187290	177790	121080	98350	2000	395000	65
	201.21	195130	165490	148810	142610	129200	112140	2000	395000	65
RR20000 L4	273.38	245740	226780	223510	183660	113320	92050	3000	395000	51
	321.63	245740	226780	223510	183660	113320	92050	3000	395000	51
	352.89	245740	226780	223510	183660	113320	92050	3000	395000	51
	381.22	245740	226780	223510	183660	113320	92050	3000	395000	51
	409.38	245740	226780	222230	180510	111380	90470	3000	395000	51
	448.50	245740	226780	223510	183660	113320	92050	3000	395000	51
	520.30	245740	226780	222230	180510	111380	90470	3000	395000	51
	611.41	245740	226780	222230	180510	111380	90470	3000	395000	51
	646.37	245740	226780	222230	180510	111380	90470	3000	395000	51
	759.56	245740	226780	222230	180510	111380	90470	3000	395000	51
	934.49	245740	226780	222230	180510	111380	90470	3000	395000	51
	1067.60	225340	206800	187290	177790	121080	98350	3000	395000	51
	1313.48	225340	206800	187290	177790	121080	98350	3000	395000	51
	1591.40	195130	165490	148810	142610	129200	112140	3000	395000	51
	1730.42	195130	165490	148810	142610	129200	112140	3000	395000	51



RR20000 A.. .. **i**



i	T ₂ [Nm]						n _{1max} [min ⁻¹]	T _{2max} [Nm]	P _t [kW]	
	n ₂ x h									
	10000 (10 ⁴)	25000 (2.5 · 10 ⁴)	50000 (5 · 10 ⁴)	100000 (10 ⁵)	500000 (5 · 10 ⁵)	1000000 (10 ⁶)				
RR20000 A3	42.88	228140	173310	140770	114340	70550	57310	2000	333010	78
	49.75	245740	192290	156190	126870	78280	63580	2000	386310	78
	57.71	226390	206800	173300	140760	86860	70550	2000	395000	78
	69.92	225340	206800	187290	161010	99350	80690	2000	395000	78
	89.96	225340	206800	187290	160860	99260	80620	2000	395000	78
	108.46	225340	206800	187290	158790	97980	79590	2000	395000	78
	131.41	195130	165490	148810	142610	112070	91030	2000	395000	78
RR20000 A4 (A)	190.05	233360	177270	143990	116960	72170	58620	2500	395000	54
	223.59	245740	198630	161340	131050	80860	65680	2500	395000	54
	259.39	245740	220390	179010	145400	89720	72880	2500	395000	54
	322.24	245740	226780	208380	169250	104440	84830	2500	395000	54
	373.82	226390	206800	187290	177790	115880	94120	2500	395000	54
	452.92	225340	206800	187290	177790	121080	98350	2500	395000	54
	548.04	225340	206800	187290	177790	121080	98350	2500	395000	54
	645.83	225340	206800	187290	177790	120440	97830	2500	395000	54
	782.49	195130	165490	148810	142610	129200	111900	2500	395000	54
(B)	192.98	245740	210510	170990	138880	85700	69610	2500	395000	56
	227.03	245740	226780	191590	155620	96020	77990	2500	395000	56
	263.38	245740	226780	212570	172660	106540	86540	2500	395000	56
	327.20	245740	226780	222230	180510	111380	90470	2500	395000	56
	374.15	245740	226780	222230	180510	111380	90470	2500	395000	56
	434.05	226390	206800	187290	177790	123580	100380	2500	395000	56
	483.36	245740	226780	222230	180510	111380	90470	2500	395000	56
	525.89	225340	206800	187290	177790	121080	98350	2500	395000	56
	560.74	226390	206800	187290	177790	123580	100380	2500	395000	56
	679.38	225340	206800	187290	177790	121080	98350	2500	395000	56
	823.14	195130	165490	148810	142610	129200	112140	2500	395000	56
(C)	171.54	245740	226780	223510	183660	113320	92050	2000	395000	62
	220.67	245740	226780	223510	183660	113320	92050	2000	395000	62
	266.07	245740	226780	223510	183660	113320	92050	2000	395000	62
	313.03	245740	226780	223510	183660	113320	92050	2000	395000	62
	374.15	245740	226780	222230	180510	111380	90470	2000	395000	62
	451.13	245740	226780	222230	180510	111380	90470	2000	395000	62
	523.35	226390	206800	187290	177790	123580	100380	2000	395000	62
	634.09	225340	206800	187290	177790	121080	98350	2000	395000	62
	768.26	195130	165490	148810	142610	129200	112140	2000	395000	62



RR20000

IT EN DE FR ES PT

RR20000 L.. .. i

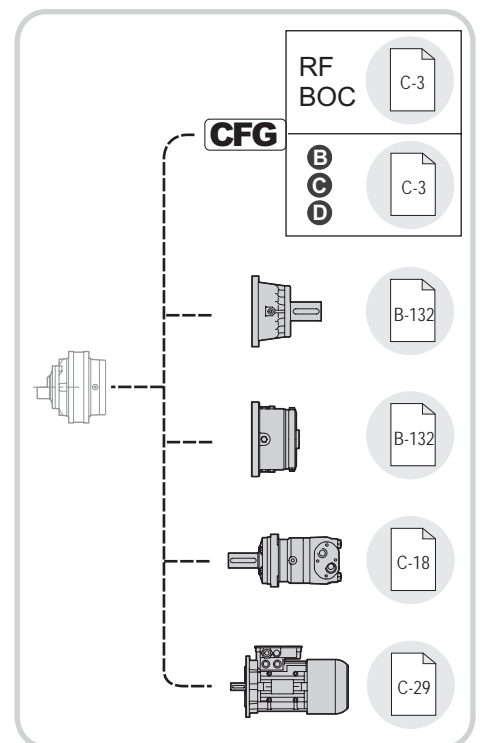
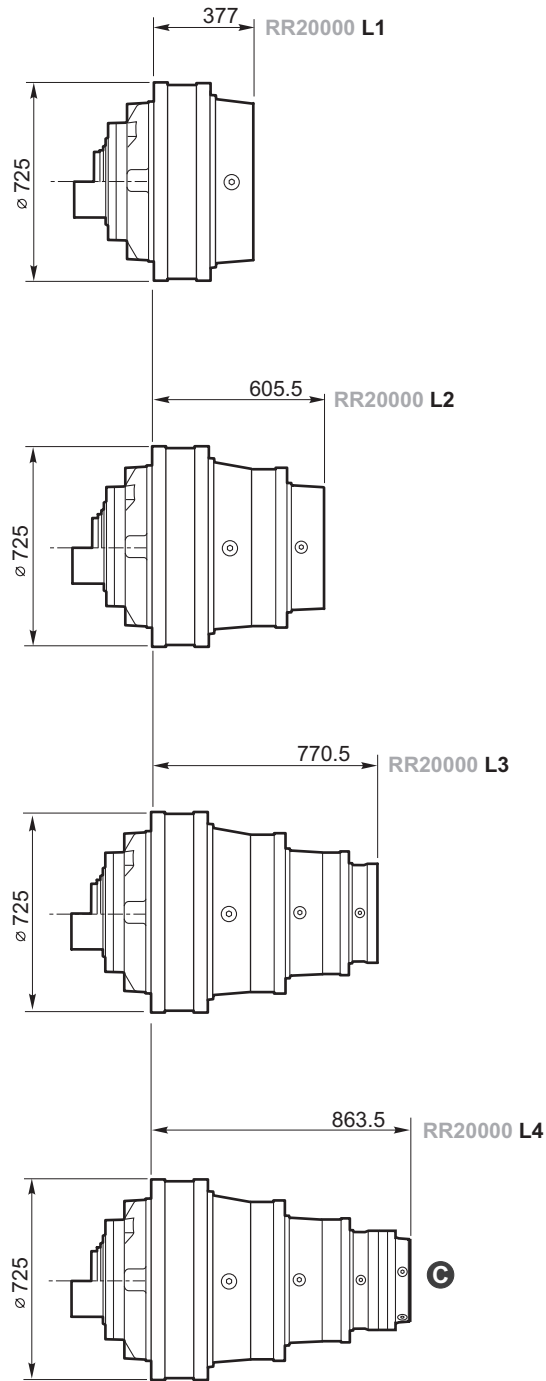

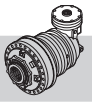

RR20000 A.. .. i

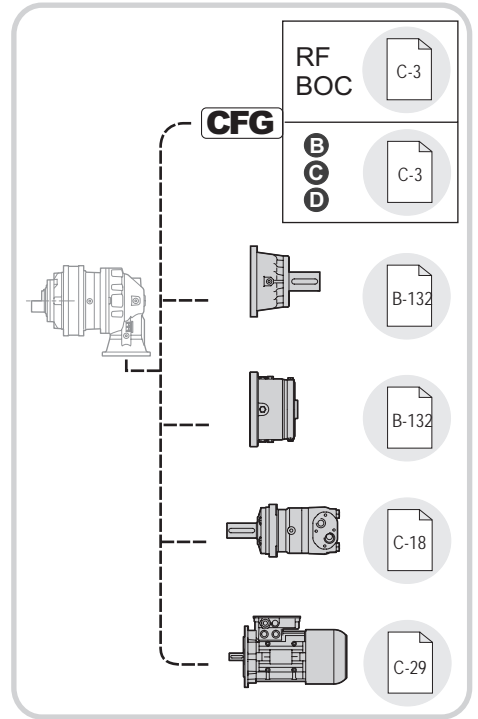
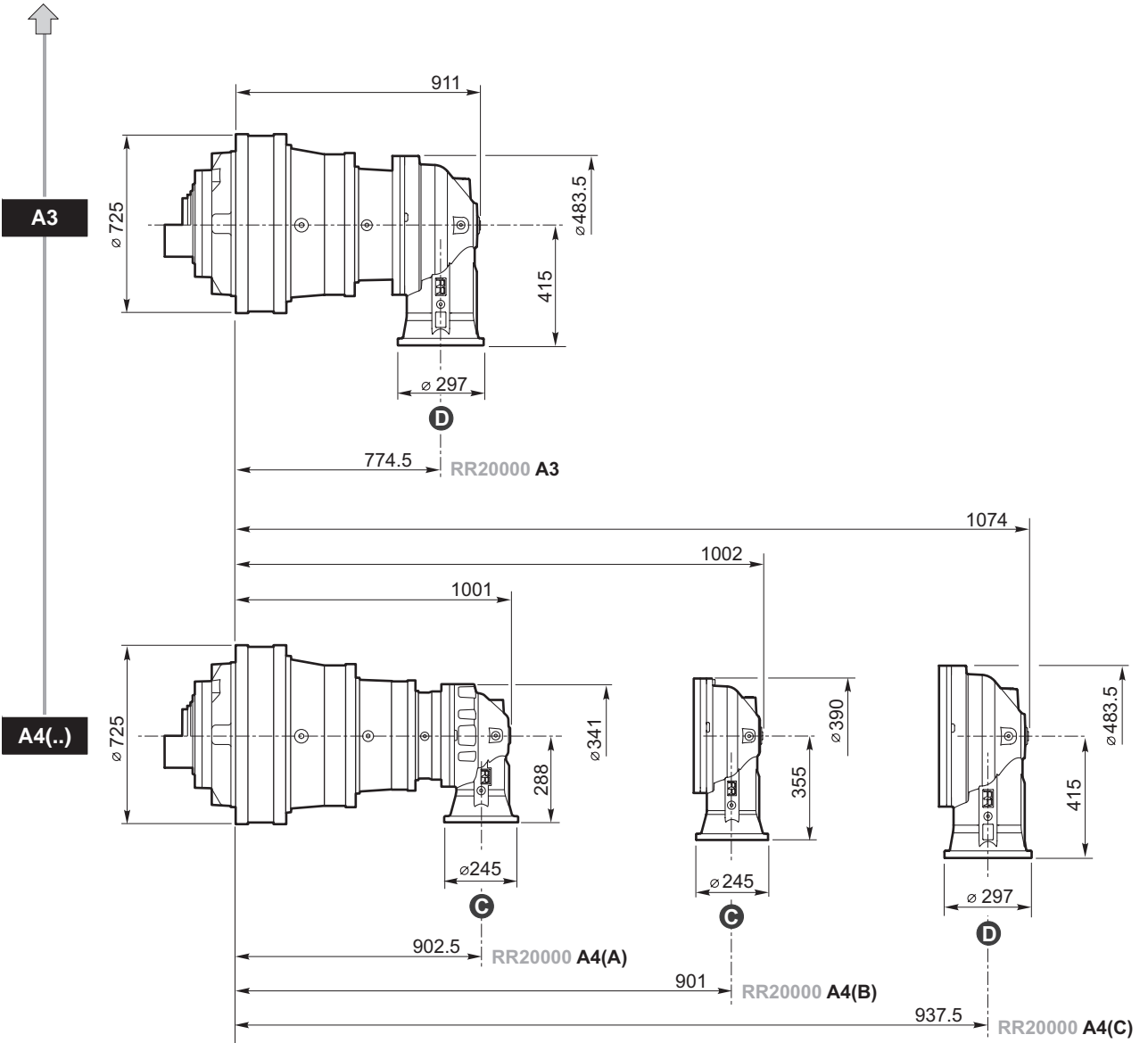

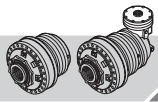

RR20000

IT EN DEFRES PT

RR20000	L..	FS	i
RR20000	A..		i

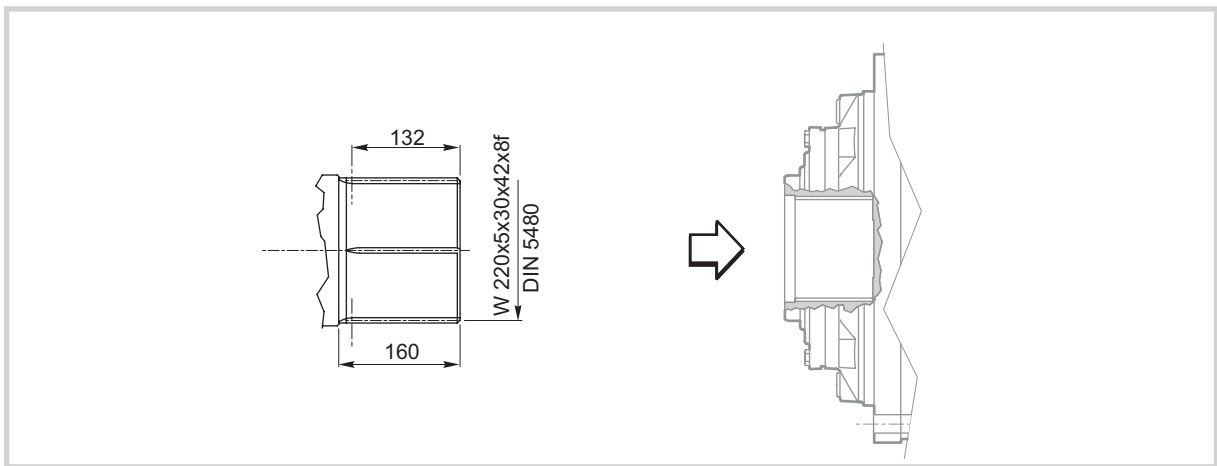
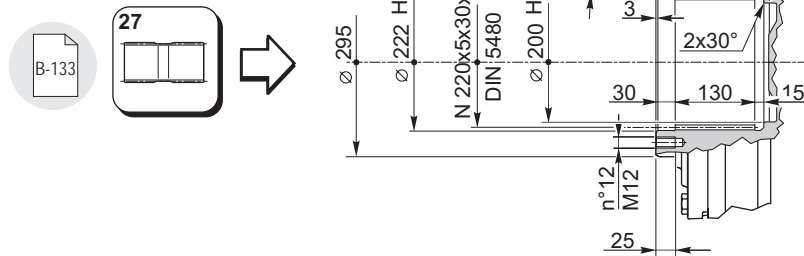
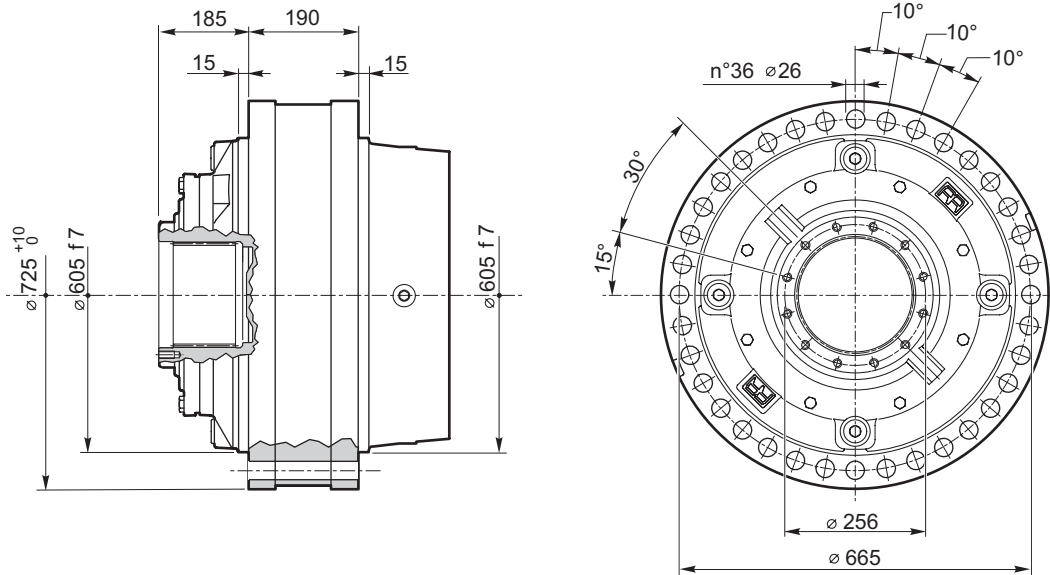



RR20000	L..	MH	i
RR20000	A..		i

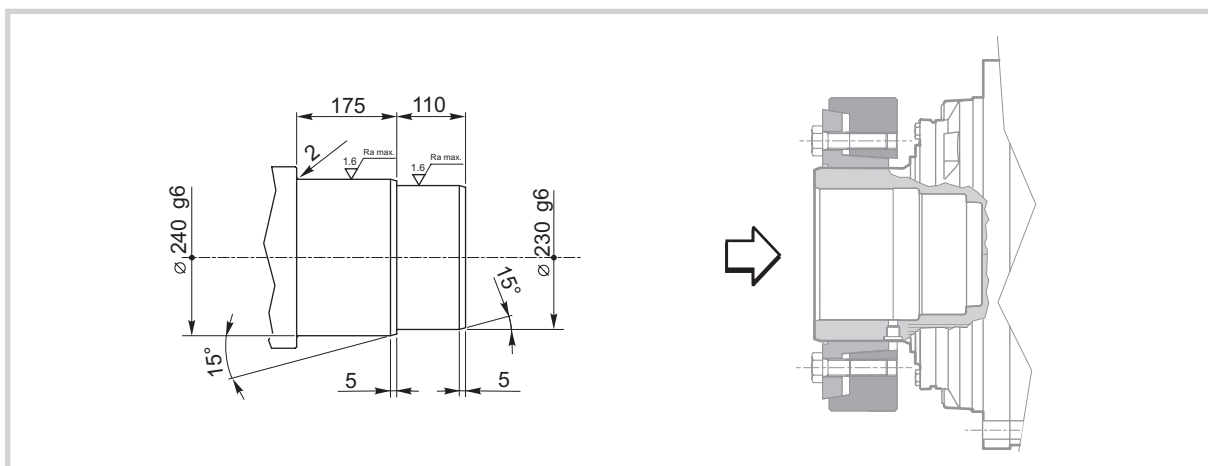
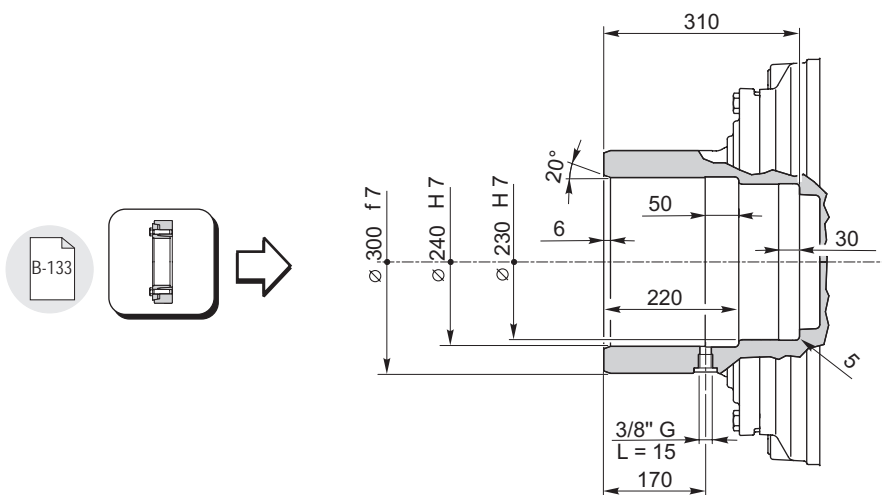
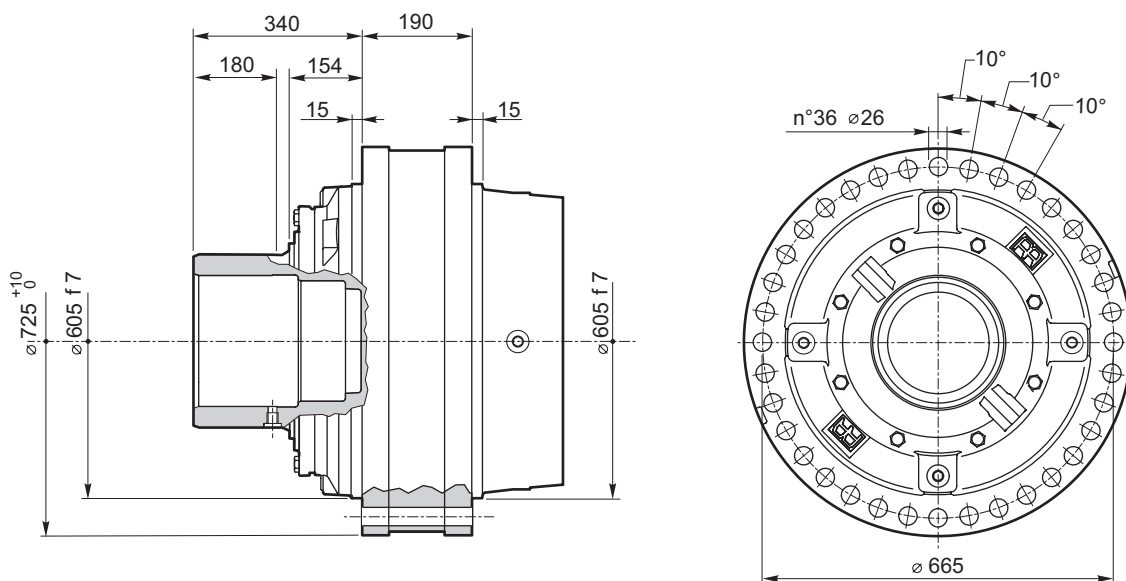

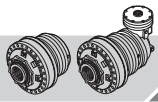

RR20000

IT EN DE FR ES PT

RF170-290



C-12

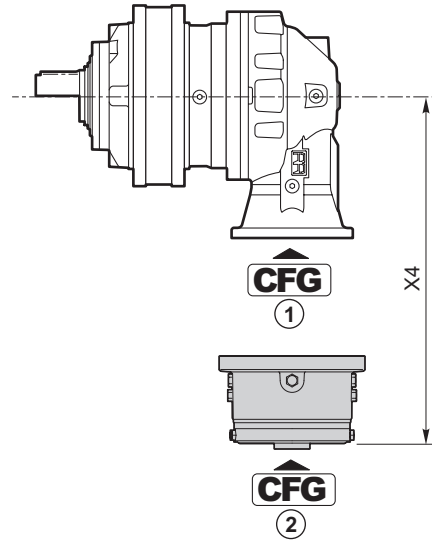
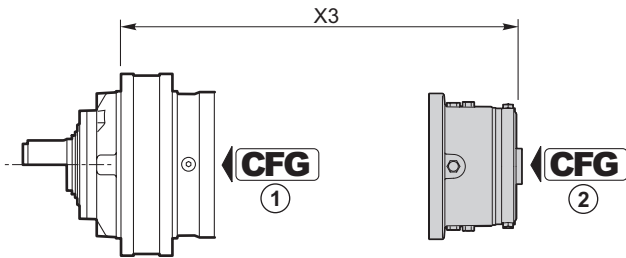

RF170-290	CFG ①	T _f [Nm]	CFG ②		
			C		
			code	X3	X4
RR20000 L4	RF	1700	154B9766M4	1060.5	—
		2000	154B9767M4		
		2300	154B9768M4		
		2900	154B9769M4		
RR20000 A4(A)	—	1700	154B9766M3	—	485
		2000	154B9767M3		
		2300	154B9768M3		
		2900	154B9769M3		
RR20000 A4(B)	—	1700	154B9766M3	—	552
		2000	154B9767M3		
		2300	154B9768M3		
		2900	154B9769M3		

CFG	
RF BOC	C-3
B C D	C-3

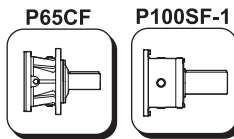

C-10

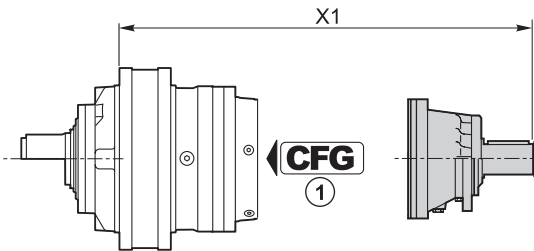

	CFG ①		code	X1
RR20000 L3	—	P100SF-1	154F3322	1147
RR20000 L4	—	P65CF	154-2404	1175.5

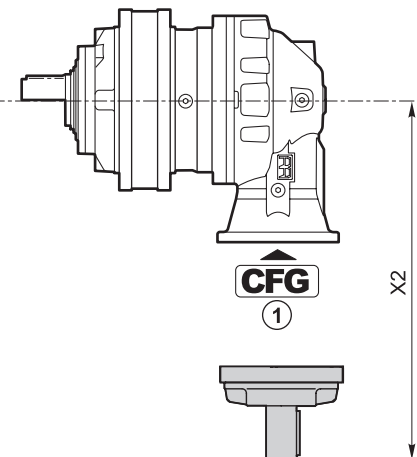

	CFG ①		code	X2
RR20000 A3	—	P100SF-1	154F3322	791.5
RR20000 A4(A)	—	P65CF	154-2404	600
RR20000 A4(B)	—	P65CF	154-2404	667
RR20000 A4(C)	—	P100SF-1	154F3322	791.5

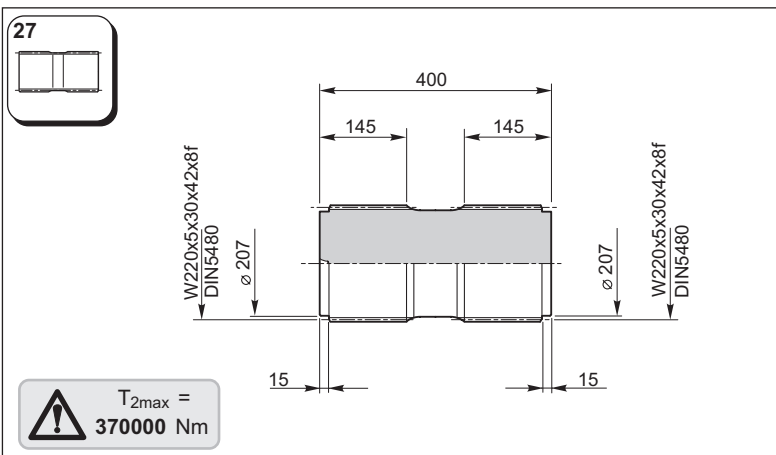
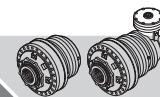

154F6042

Materiale / Material / Material / Matériau / Material / Material:
Acciaio / Steel / Stahl / Acier / Acero / Aço
EN 10083-1-42CrMo4+QT (1.7225)

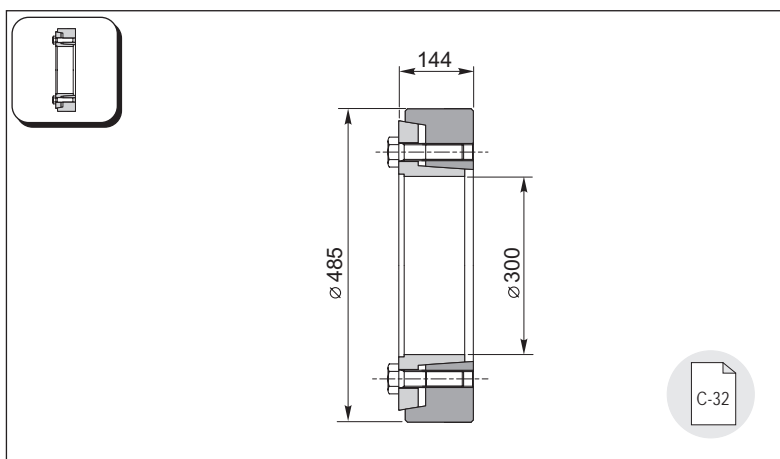

154F6070

**ATTENZIONE**

Il valore di T_{2max} indicato costituisce una limitazione del valore relativo al riduttore, riportato nella tabella dei dati tecnici per ciascuna grandezza.

ATTENTION

Le valeur de T_{2max} indiquée représente une restriction de la valeur relative au réducteur et indiquée sur le tableau des caractéristiques techniques pour chaque grandeur.

ATENCIÓN

The T_{2max} value indicated is a limit of the reduction gear value, given in the technical data table for each size.

ATENÇÃO

El valor de T_{2max} indicado constituye una limitación del valor referente al reductor, indicado en la tabla de los datos técnicos para cada talla.

ACHTUNG!

Der angegebene Wert T_{2max} stellt eine Einschränkung vom entsprechenden Wert am Untersetzungsgetriebe dar, der in der Tabelle mit den technischen Daten für jede Größe angegeben ist.

ATENÇÃO

O valor T_{2max} indicado representa uma limitação do valor relativo ao redutor, indicado na tabela dos dados técnicos para cada grandeza.



RR25000

IT EN DE FR ES PT

RR25000 L.. .. **i**



i	T ₂ [Nm]						n _{1max} [min ⁻¹]	T _{2max} [Nm]	P _t [kW]	
	n ₂ x h									
1/...	10000 (10 ⁴)	25000 (2.5 · 10 ⁴)	50000 (5 · 10 ⁴)	100000 (10 ⁵)	500000 (5 · 10 ⁵)	1000000 (10 ⁶)				
RR25000 L1	4.17	333220	307380	303140	283670	213800	173660	500	580000	186
	4.84	319970	289150	255630	242690	210150	170700	500	580000	186
	5.87	266210	226030	203380	194910	176580	167230	500	580000	186
RR25000 L2	17.42	333220	307380	303140	278100	171600	139380	750	580000	113
	20.21	333220	307380	303140	273250	168600	136950	750	580000	113
	23.45	319970	289150	255630	242690	187070	151950	750	580000	113
	28.41	308240	289150	255630	242690	182800	148480	750	580000	113
	34.42	266210	226030	203380	194910	176580	167230	750	580000	113
RR25000 L3	72.72	333220	307380	303140	278100	171600	139380	1000	580000	83
	81.01	333220	307380	303140	278100	171600	139380	1000	580000	83
	92.23	333220	307380	303140	278100	171600	139380	1000	580000	83
	107.00	333220	307380	303140	273250	168600	136950	1000	580000	83
	125.59	333220	307380	303140	273250	168600	136950	1000	580000	83
	132.09	308240	289150	255630	242690	182800	148480	1000	580000	83
	150.39	308240	289150	255630	242690	182800	148480	1000	580000	83
	176.53	308240	289150	255630	242690	182800	148480	1000	580000	83
	213.88	266210	226030	203380	194910	176580	167230	1000	580000	83
RR25000 L4	283.59	333220	307380	303140	278100	171600	139380	2000	580000	65
	328.99	333220	307380	303140	273250	168600	136950	2000	580000	65
	366.52	333220	307380	303140	273250	168600	136950	2000	580000	65
	417.29	333220	307380	303140	273250	168600	136950	2000	580000	65
	456.13	333220	307380	303140	278100	171600	139380	2000	580000	65
	489.82	333220	307380	303140	273250	168600	136950	2000	580000	65
	550.27	333220	307380	303140	273250	168600	136950	2000	580000	65
	589.50	333220	307380	303140	273250	168600	136950	2000	580000	65
	645.91	333220	307380	303140	273250	168600	136950	2000	580000	65
	679.10	333220	307380	303140	278100	171600	139380	2000	580000	65
	787.82	333220	307380	303140	273250	168600	136950	2000	580000	65
	828.58	308240	289150	255630	242690	182800	148480	2000	580000	65
	943.36	308240	289150	255630	242690	182800	148480	2000	580000	65
	1107.32	308240	289150	255630	242690	182800	148480	2000	580000	65
	1341.62	266210	226030	203380	194910	176580	167230	2000	580000	65

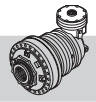

RR25000 A.. .. **i**



i	T ₂ [Nm]						n _{1max} [min ⁻¹]	T _{2max} [Nm]	P _t [kW]
	n ₂ x h								
	10000 (10 ⁴)	25000 (2.5 · 10 ⁴)	50000 (5 · 10 ⁴)	100000 (10 ⁵)	500000 (5 · 10 ⁵)	1000000 (10 ⁶)			

RR25000 A4 (A)	198.32	240420	182640	148350	120490	74350	60390	2500	580000	69
	220.94	259300	196980	160000	129960	80190	65130	2500	580000	69
	251.54	283950	215710	175210	142310	87810	71330	2500	580000	69
	291.81	315050	239330	194400	157900	97430	79140	2500	580000	69
	360.25	308240	277370	225290	183000	112910	91720	2500	580000	69
	410.15	308240	289150	246710	200390	123650	100430	2500	580000	69
	481.44	308240	289150	255630	224180	138330	112360	2500	580000	69
	582.55	308240	289150	255630	215830	133180	108170	2500	580000	69
	705.81	266210	226030	203380	194910	152330	123730	2500	580000	69
	831.76	266210	226030	203380	194910	143780	116780	2500	580000	69
(B)	201.37	285490	216870	176160	143080	88290	71710	2500	580000	71
	255.41	333220	256140	208050	168990	104270	84700	2500	580000	71
	296.30	333220	284200	230840	187500	115700	93970	2500	580000	71
	365.79	308240	289150	255630	217300	134080	108910	2500	580000	71
	416.46	308240	289150	255630	237960	146830	119260	2500	580000	71
	488.85	308240	289150	255630	242690	164260	133420	2500	580000	71
	559.01	308240	289150	255630	242690	166320	135100	2500	580000	71
	615.23	308240	289150	255630	239500	147780	120040	2500	580000	71
	722.17	308240	289150	255630	242690	165320	134290	2500	580000	71
	874.97	266210	226030	203380	194910	176580	153600	2500	580000	71
(C)	178.99	333220	307380	303140	278100	171600	139380	2000	580000	77
	230.27	333220	307380	303140	278100	171600	139380	2000	580000	77
	277.64	333220	307380	303140	278100	171600	139380	2000	580000	77
	309.31	333220	307380	303140	278100	171600	139380	2000	580000	77
	352.16	333220	307380	303140	278100	171600	139380	2000	580000	77
	408.53	333220	307380	303140	273250	168600	136950	2000	580000	77
	479.54	333220	307380	303140	273250	168600	136950	2000	580000	77
	559.01	308240	289150	255630	242690	182800	148480	2000	580000	77
	674.02	308240	289150	255630	242690	182800	148480	2000	580000	77
	816.64	266210	226030	203380	194910	176580	167230	2000	580000	77



RR25000

IT EN DE FR ES PT

RR25000 L.. .. i

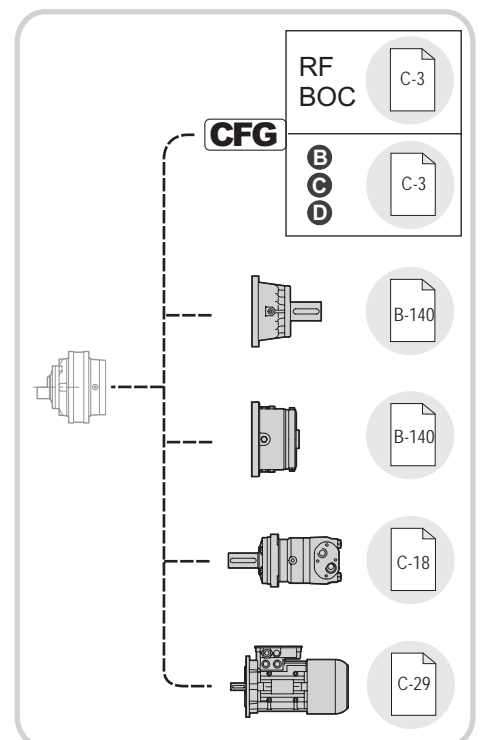
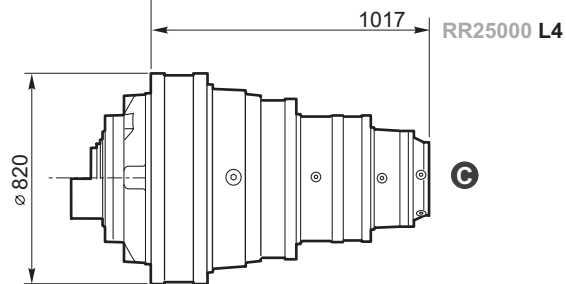
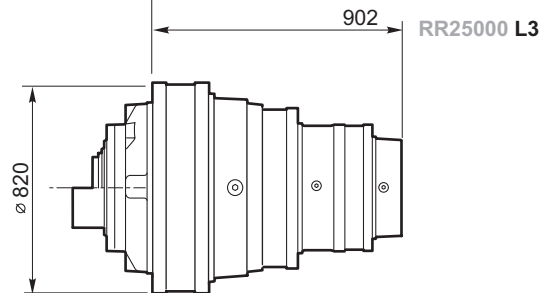
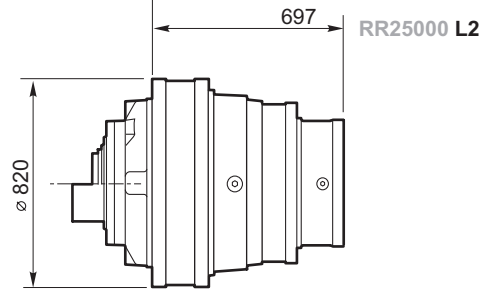
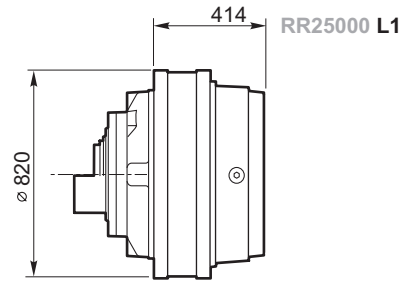

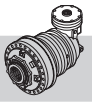

RR25000 A.. .. i

A4(..)

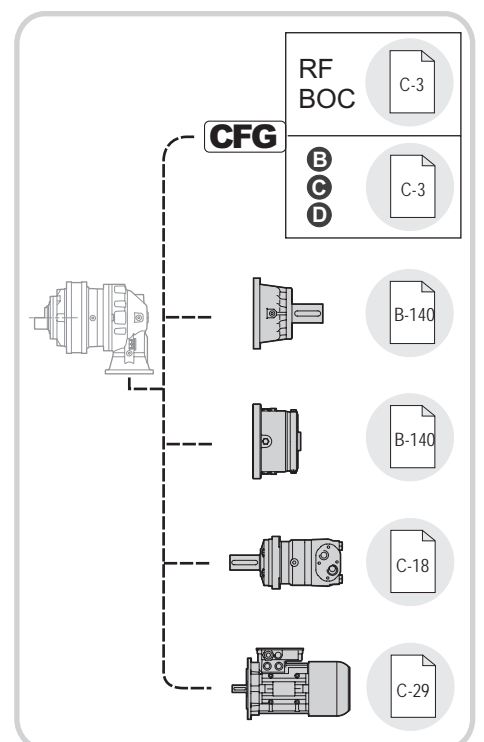
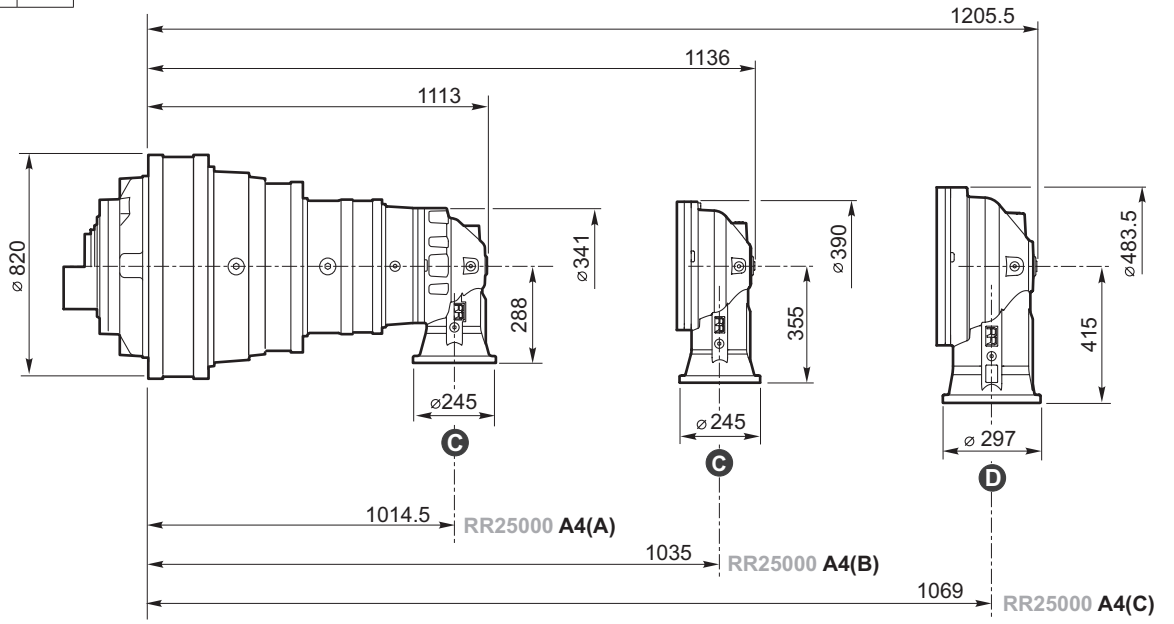

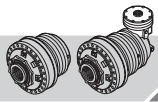

RR25000

IT EN DEFRES PT

RR25000	L..	FS	i
RR25000	A..		i

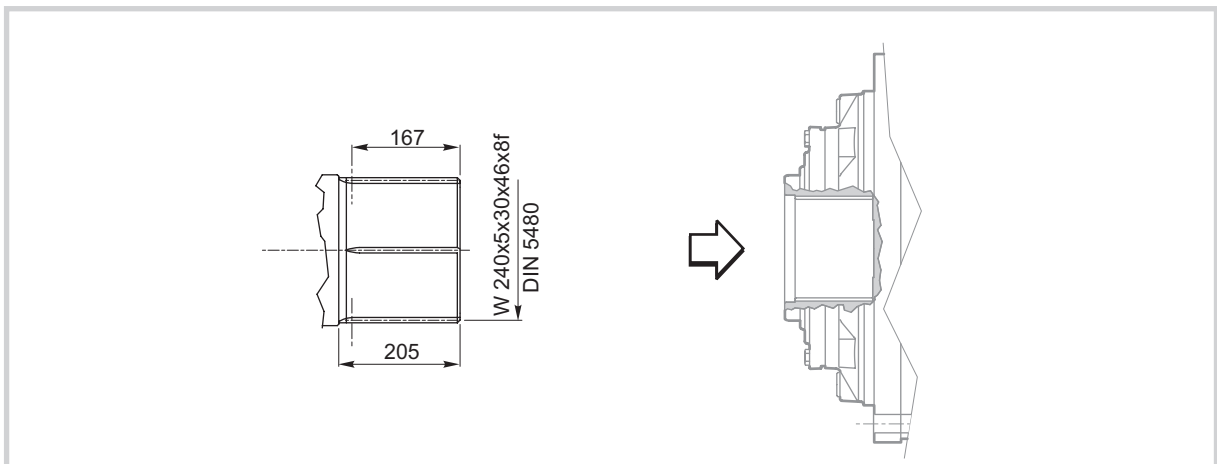
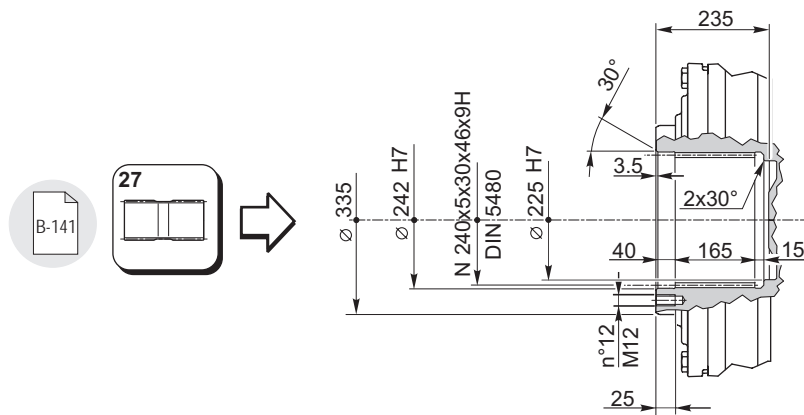
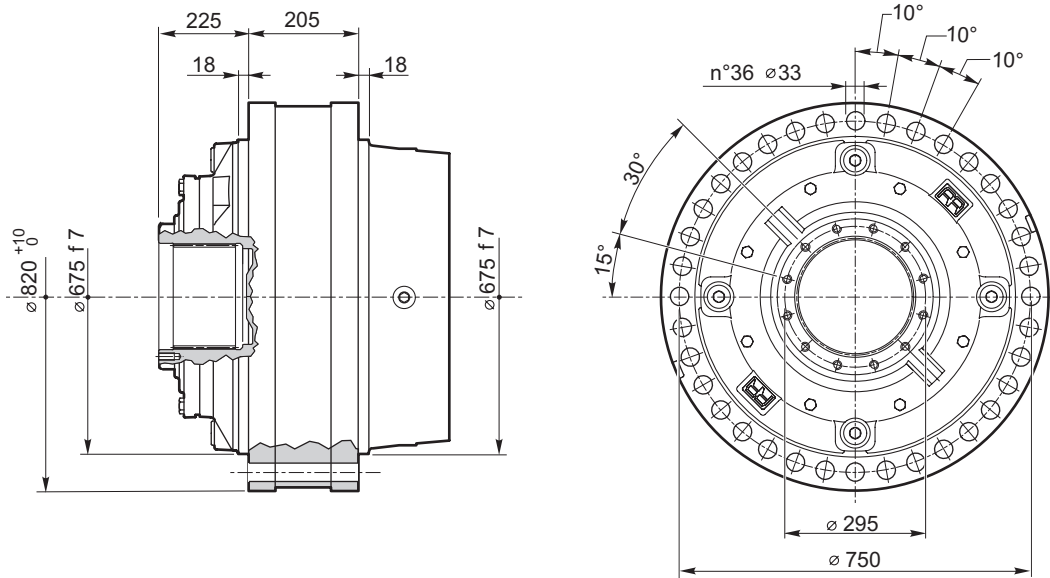

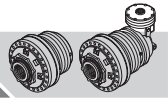

RR25000	L..	MH	i
RR25000	A..		i

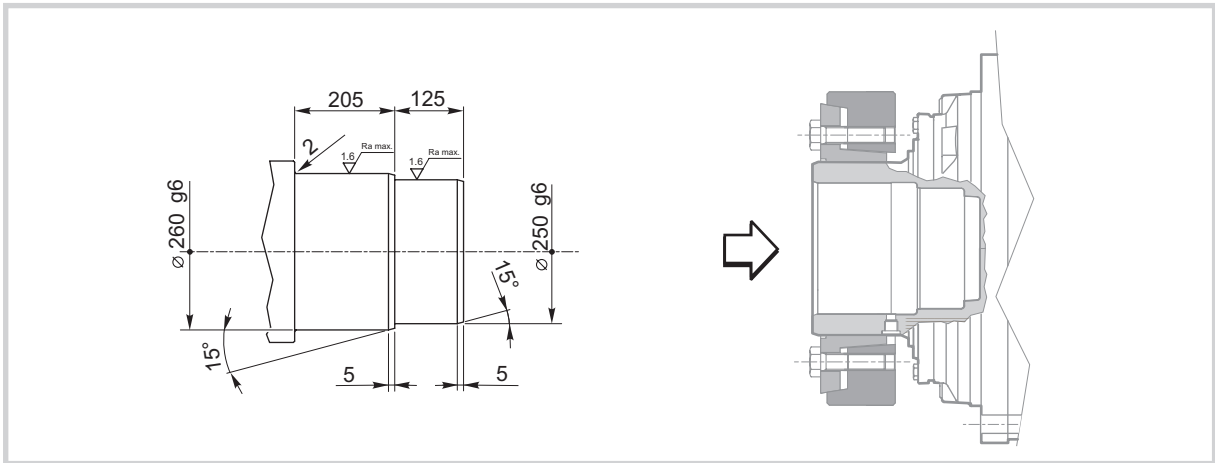
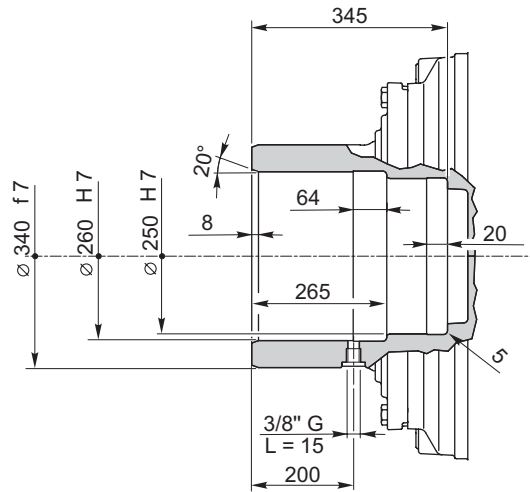
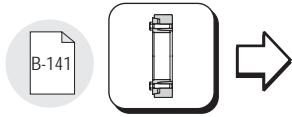
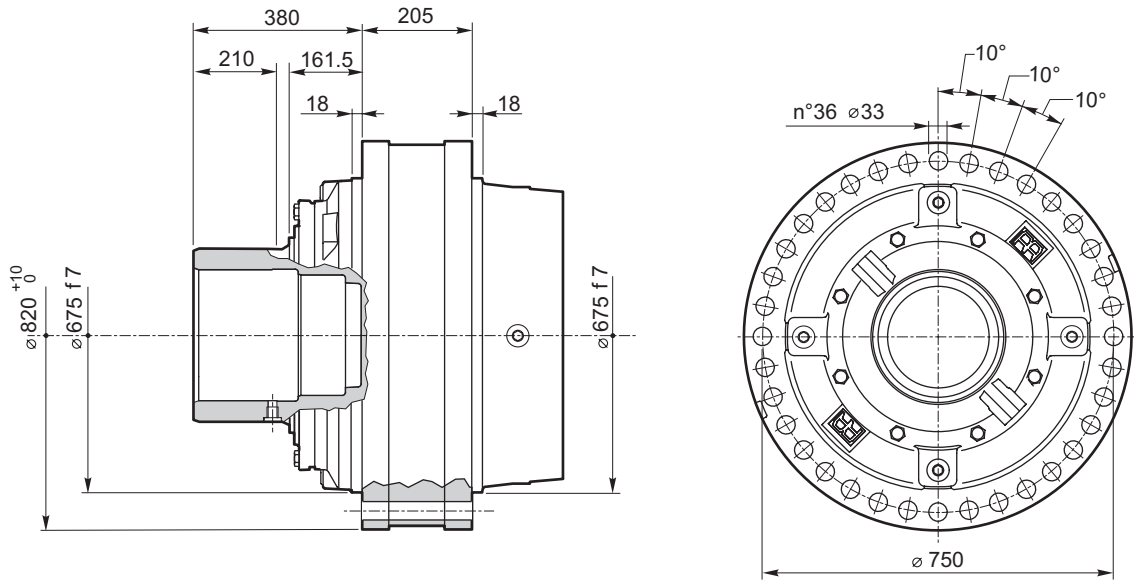

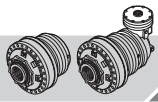

RR25000

IT EN DE FR ES PT

RF170-290



C-12

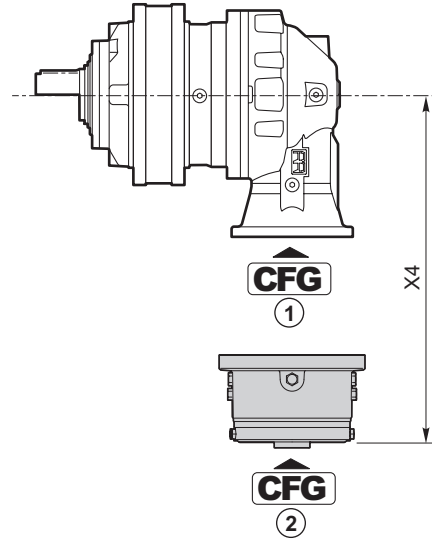
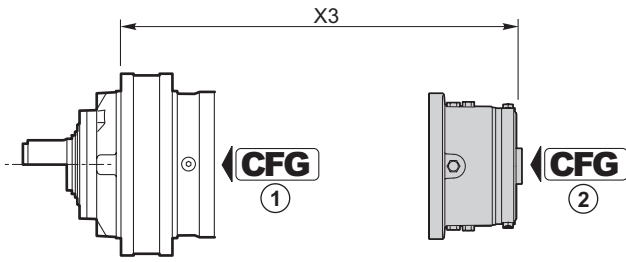

RF170-290	CFG ①	T _f [Nm]	CFG ②		
			C		
			code	X3	X4
RR25000 L4	RF	1700	154B9766M2	1214	—
		2000	154B9767M2		
		2300	154B9768M2		
		2900	154B9769M2		
RR25000 A4(A)	—	1700	154B9766M3	—	485
		2000	154B9767M3		
		2300	154B9768M3		
		2900	154B9769M3		
RR25000 A4(B)	—	1700	154B9766M3	—	552
		2000	154B9767M3		
		2300	154B9768M3		
		2900	154B9769M3		

CFG	
RF BOC	C-3
B C D	C-3

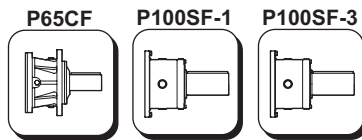

C-10

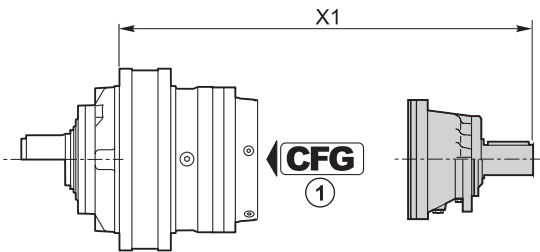

	CFG ①		code	X1
RR25000 L3	—	P100SF-3	154F3324	1279
RR25000 L4	—	P65CF	154-2404	1329

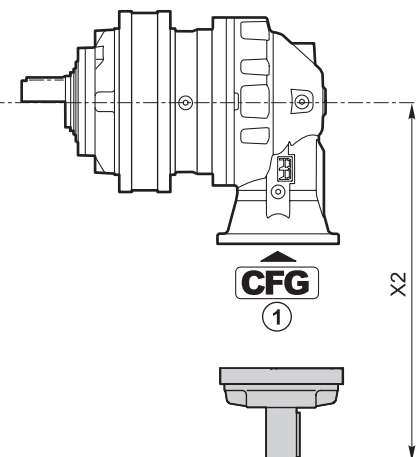

	CFG ①		code	X2
RR25000 A4(A)	—	P65CF	154-2404	600
RR25000 A4(B)	—	P65CF	154-2404	667
RR25000 A4(C)	—	P100SF-1	154F3322	791.5

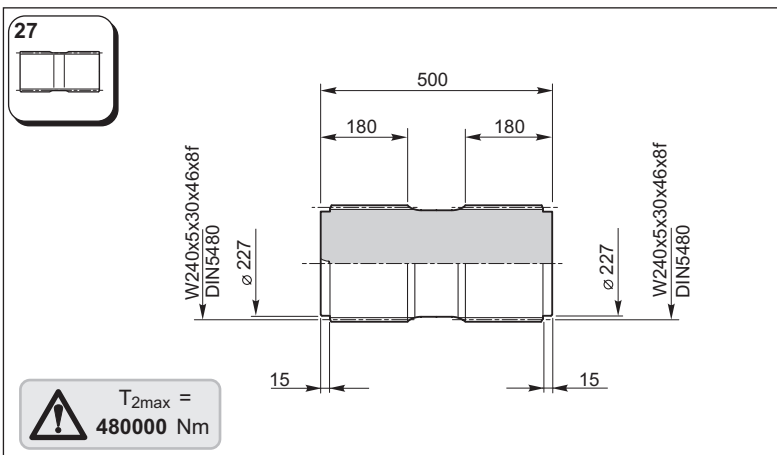
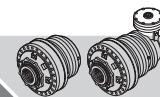

154F6043

Materiale / Material / Material / Matériau / Material / Material:
Acciaio / Steel / Stahl / Acier / Acero / Aço
EN 10083-1-42CrMo4+QT (1.7225)

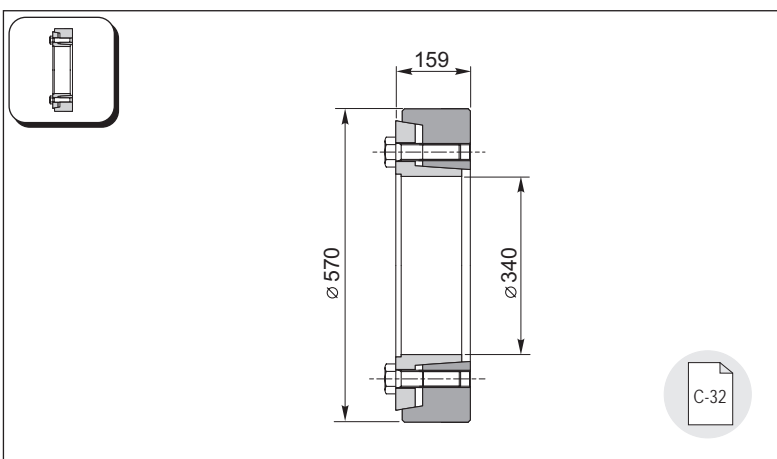

154F6071

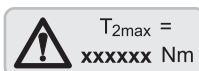
**ATTENZIONE**

Il valore di T_{2max} indicato costituisce una limitazione del valore relativo al riduttore, riportato nella tabella dei dati tecnici per ciascuna grandezza.

ATTENTION

Le valeur de T_{2max} indiquée représente une restriction de la valeur relative au réducteur et indiquée sur le tableau des caractéristiques techniques pour chaque grandeur.

ATTENTION

The T_{2max} value indicated is a limit of the reduction gear value, given in the technical data table for each size.

ATENCIÓN

El valor de T_{2max} indicado constituye una limitación del valor referente al reductor, indicado en la tabla de los datos técnicos para cada talla.

ACHTUNG!

Der angegebene Wert T_{2max} stellt eine Einschränkung vom entsprechenden Wert am Untersetzungsgetriebe dar, der in der Tabelle mit den technischen Daten für jede Größe angegeben ist.

ATENÇÃO

O valor T_{2max} indicado representa uma limitação do valor relativo ao redutor, indicado na tabela dos dados técnicos para cada grandeza.



RR30000

IT EN DE FR ES PT

RR30000 L.. .. **i**



i	T ₂ [Nm]						n _{1max} [min ⁻¹]	T _{2max} [Nm]	P _t [kW]	
	n ₂ x h									
1/...	10000 (10 ⁴)	25000 (2.5 · 10 ⁴)	50000 (5 · 10 ⁴)	100000 (10 ⁵)	500000 (5 · 10 ⁵)	1000000 (10 ⁶)				
RR30000 L1	4.17	359290	331270	326700	317040	210000	170580	300	680000	236
	4.65	355960	325700	319930	292190	205430	166860	300	680000	236
	5.29	337940	298600	264140	245720	204360	165990	300	680000	236
	6.21	283510	240980	213100	202730	183670	161570	300	680000	236
RR30000 L2	17.42	359290	331270	326700	317040	210000	170580	500	680000	143
	20.21	359290	331270	326700	317040	210000	170580	500	680000	143
	24.49	359290	331270	326700	317040	210000	170580	500	680000	143
	27.28	355960	325700	319930	292190	205430	166860	500	680000	143
	31.06	337940	298600	264140	245720	204360	165990	500	680000	143
	36.46	283510	240980	213100	202730	183670	161570	500	680000	143
RR30000 L3	72.72	359290	331270	326700	317040	210000	170580	1000	680000	103
	84.36	359290	331270	326700	317040	210000	170580	1000	680000	103
	102.21	359290	331270	326700	317040	210000	170580	1000	680000	103
	118.57	359290	331270	326700	317040	210000	170580	1000	680000	103
	143.66	359290	331270	326700	317040	210000	170580	1000	680000	103
	160.04	355960	325700	319930	292190	205430	166860	1000	680000	103
	182.21	337940	298600	264140	245720	204360	165990	1000	680000	103
	213.88	283510	240980	213100	202730	183670	161570	1000	680000	103
RR30000 L4	283.59	359290	331270	326700	317040	210000	170580	2000	680000	81
	328.99	359290	331270	326700	317040	210000	170580	2000	680000	81
	398.61	359290	331270	326700	317040	210000	170580	2000	680000	81
	450.91	359290	331270	326700	317040	210000	170580	2000	680000	81
	503.29	359290	331270	326700	317040	210000	170580	2000	680000	81
	560.26	359290	331270	326700	317040	210000	170580	2000	680000	81
	633.78	359290	331270	326700	317040	210000	170580	2000	680000	81
	738.81	359290	331270	326700	317040	210000	170580	2000	680000	81
	828.58	355960	325700	319930	292190	205430	166860	2000	680000	81
	901.12	359290	331270	326700	317040	210000	170580	2000	680000	81
	1003.90	355960	325700	319930	292190	205430	166860	2000	680000	81
	1142.96	337940	298600	264140	245720	204360	165990	2000	680000	81
	1341.62	283510	240980	213100	202730	183670	161570	2000	680000	81

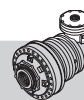

RR30000 A.. .. **i**



i	T ₂ [Nm]						n _{1max} [min ⁻¹]	T _{2max} [Nm]	P _t [kW]
	n ₂ x h								
1/...	10000 (10 ⁴)	25000 (2.5 · 10 ⁴)	50000 (5 · 10 ⁴)	100000 (10 ⁵)	500000 (5 · 10 ⁵)	1000000 (10 ⁶)			

RR30000 A4 (A)	198.32	240420	182640	148350	120490	74350	60390	2500	680000	84
	230.06	266750	202640	164600	133690	82490	67010	2500	680000	84
	278.74	305110	231780	188270	152920	94360	76640	2500	680000	84
	323.37	338540	257170	208890	169670	104690	85040	2500	680000	84
	391.79	359290	294150	238930	194070	119750	97260	2500	680000	84
	436.48	355960	317260	257690	209310	129150	104900	2500	680000	84
	496.94	337940	298600	264140	229210	141430	114880	2500	680000	84
	583.31	283510	240980	213100	202730	158220	128510	2500	680000	84
	705.81	283510	240980	213100	202730	152330	123730	2500	680000	84
	831.76	283510	240980	213100	202730	143780	116780	2500	680000	84
(B)	201.37	285490	216870	176160	143080	88290	71710	2500	680000	86
	233.60	316760	240630	195450	158760	97960	79570	2500	680000	86
	283.03	359290	275230	223560	181590	112040	91010	2500	680000	86
	328.34	359290	305380	248050	201480	124320	100980	2500	680000	86
	397.82	359290	331270	283720	230450	142190	115500	2500	680000	86
	443.20	355960	325700	306000	248550	153360	124570	2500	680000	86
	504.59	337940	298600	264140	245720	167940	136410	2500	680000	86
	577.00	337940	298600	264140	245720	170050	138130	2500	680000	86
	654.72	355960	325700	307990	250160	154360	125380	2500	680000	86
	745.41	337940	298600	264140	245720	169030	137300	2500	680000	86
874.97	283510	240980	213100	202730	183670	153600	2500	680000	86	
(C)	178.99	359290	331270	326700	303100	187020	151910	2000	680000	93
	207.65	359290	331270	326700	317040	207510	168550	2000	680000	93
	251.59	359290	331270	326700	317040	210000	170580	2000	680000	93
	291.86	359290	331270	326700	317040	210000	170580	2000	680000	93
	323.65	359290	331270	326700	317040	210000	170580	2000	680000	93
	390.24	359290	331270	326700	317040	210000	170580	2000	680000	93
	452.72	359290	331270	326700	317040	210000	170580	2000	680000	93
	506.80	355960	325700	319930	292190	205430	166860	2000	680000	93
	548.51	359290	331270	326700	317040	210000	170580	2000	680000	93
	611.07	355960	325700	319930	292190	205430	166860	2000	680000	93
	695.72	337940	298600	264140	245720	204360	165990	2000	680000	93
	816.64	283510	240980	213100	202730	183670	161570	2000	680000	93



RR30000

IT EN DE FR ES PT

RR30000 L.. .. i

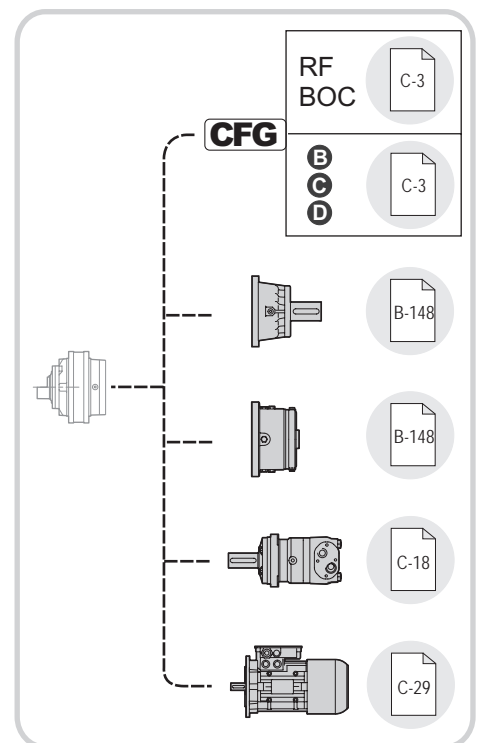
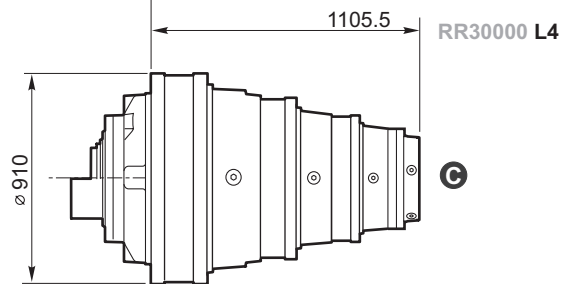
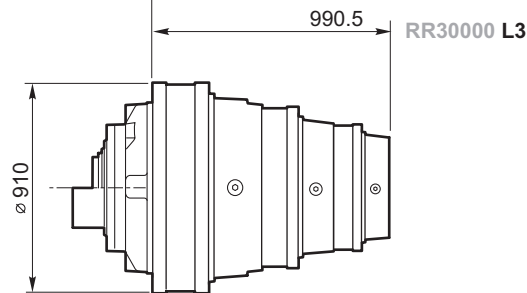
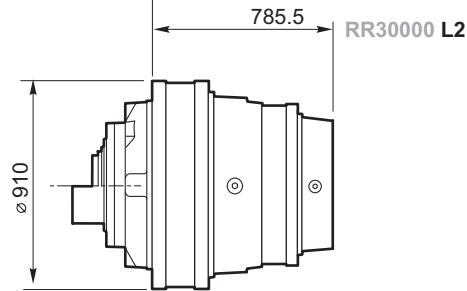
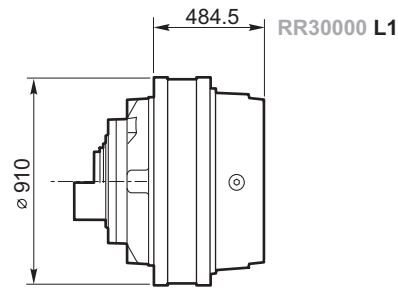

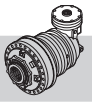

RR30000 A.. .. i

A4(..)

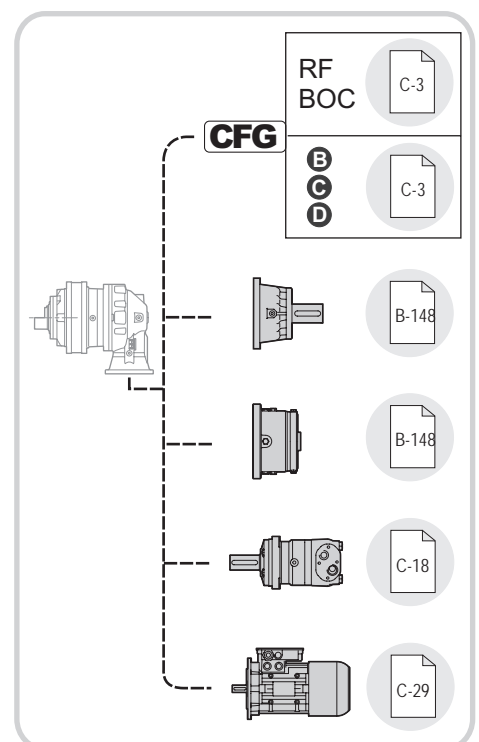
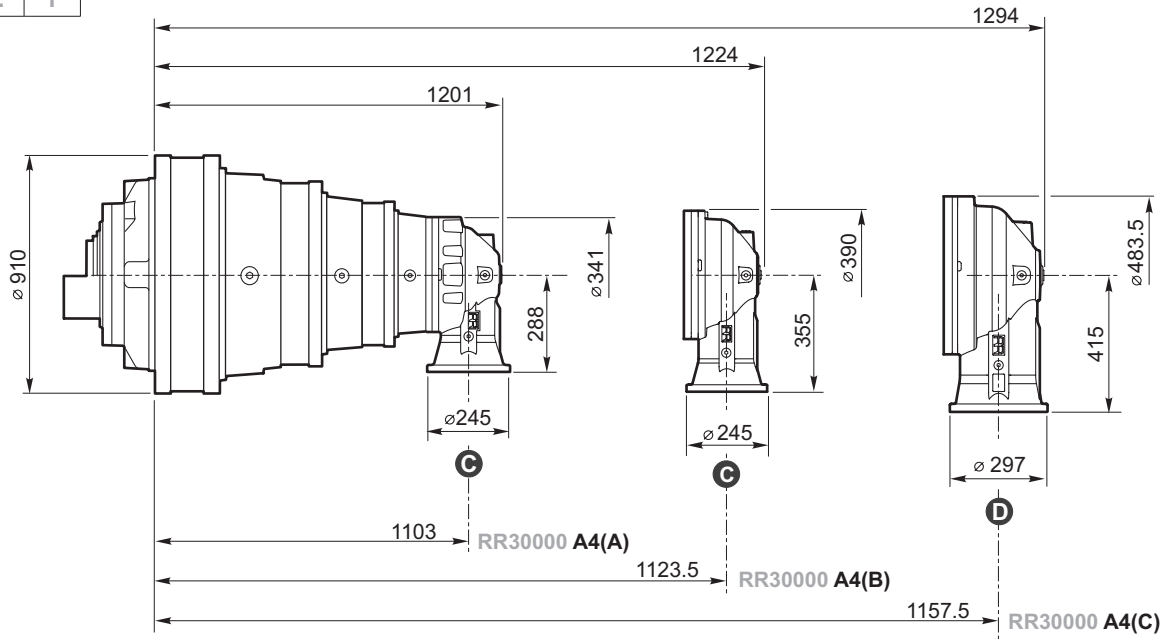

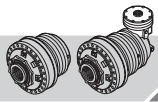

RR30000

IT EN DEFRES PT

RR30000	L..	FS	i
RR30000	A..		i

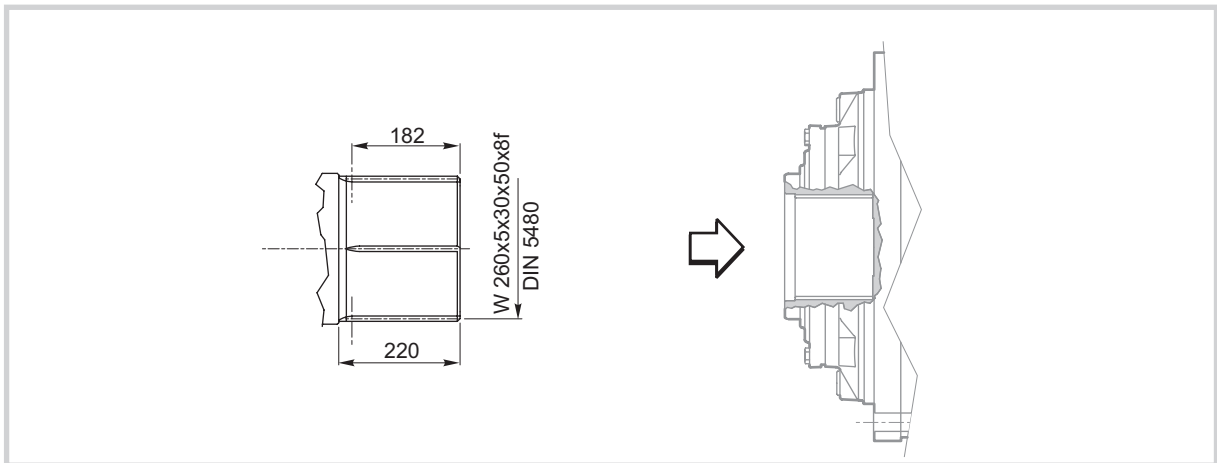
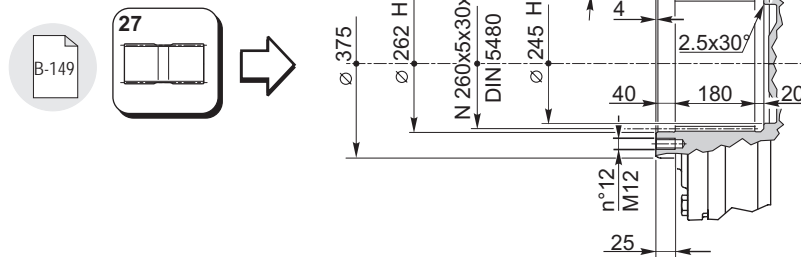
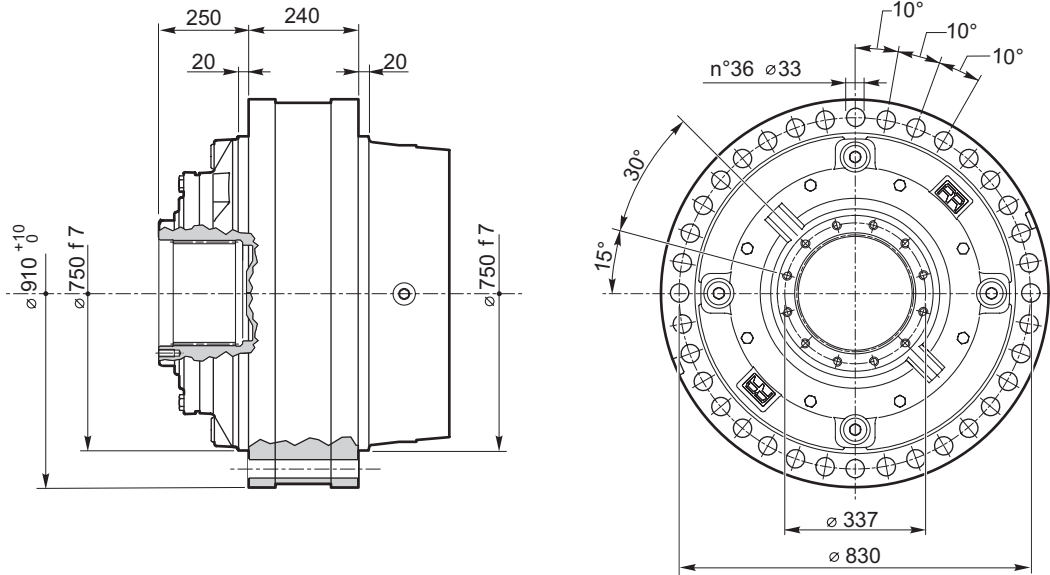

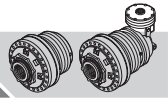

RR30000	L..	MH	i
RR30000	A..		i

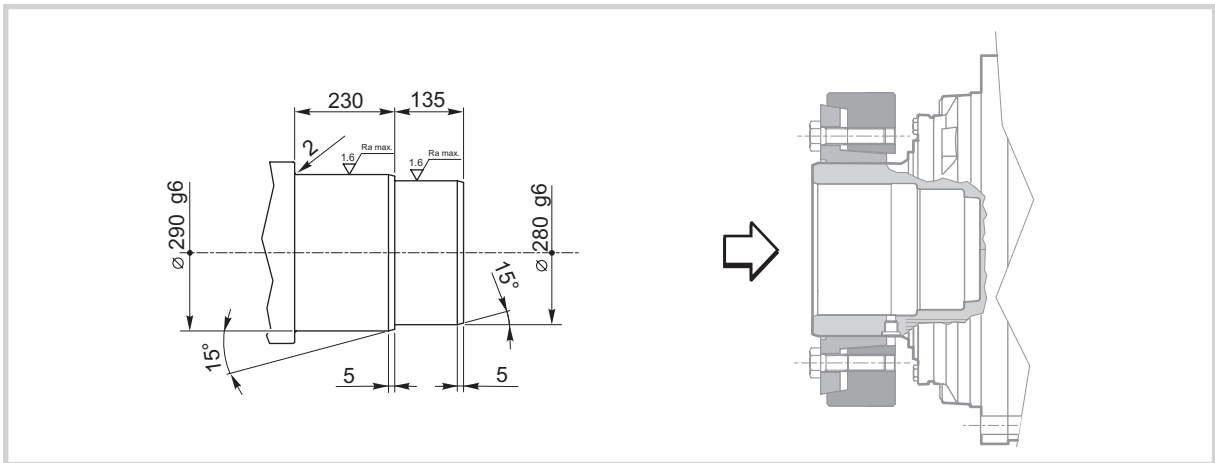
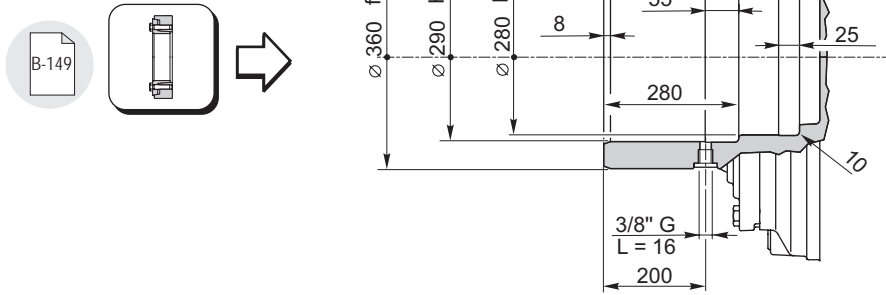
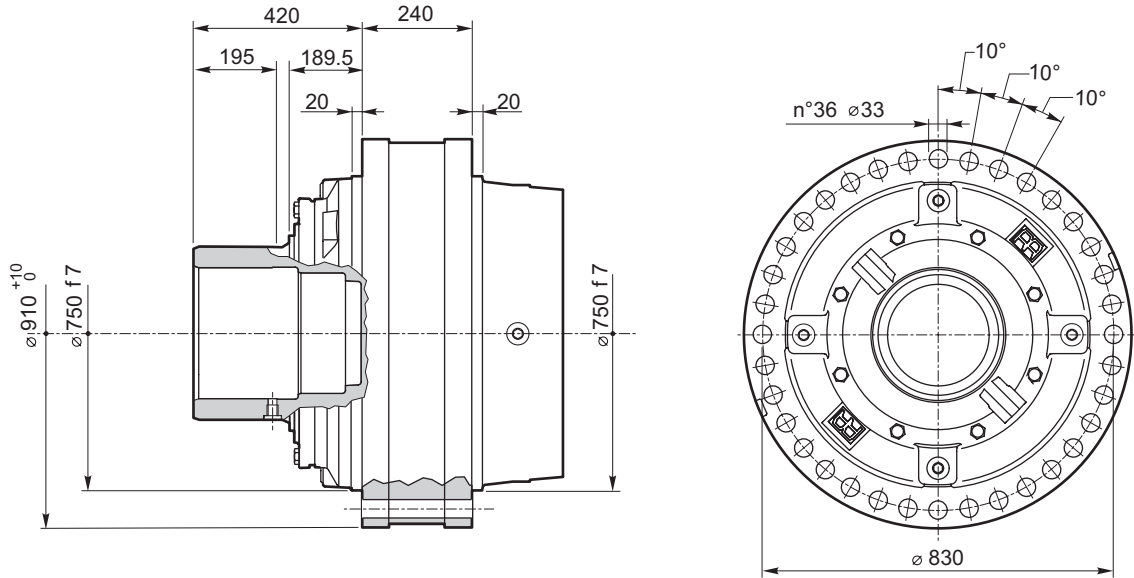

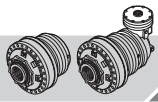

RR30000

IT EN DE FR ES PT

RF170-290



C-12

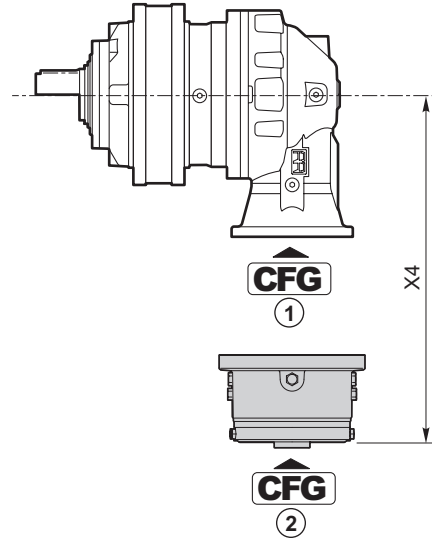
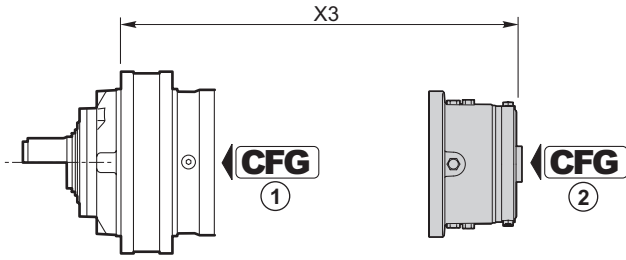

RF170-290	CFG ①	T _f [Nm]	CFG ②		
			C		
			code	X3	X4
RR30000 L4	RF	1700	154B9766M2	1302.5	—
		2000	154B9767M2		
		2300	154B9768M2		
		2900	154B9769M2		
RR30000 A4(A)	—	1700	154B9766M3	—	485
		2000	154B9767M3		
		2300	154B9768M3		
		2900	154B9769M3		
RR30000 A4(B)	—	1700	154B9766M3	—	552
		2000	154B9767M3		
		2300	154B9768M3		
		2900	154B9769M3		

CFG	
RF BOC	C-3
B C D	C-3

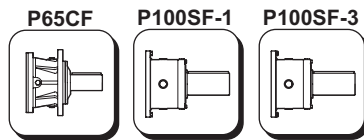

C-10

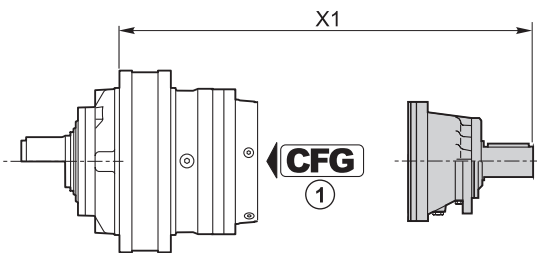

	CFG ①		code	X1
RR30000 L3	—	P100SF-3	154F3324	1367.5
RR30000 L4	—	P65CF	154-2404	1417.5

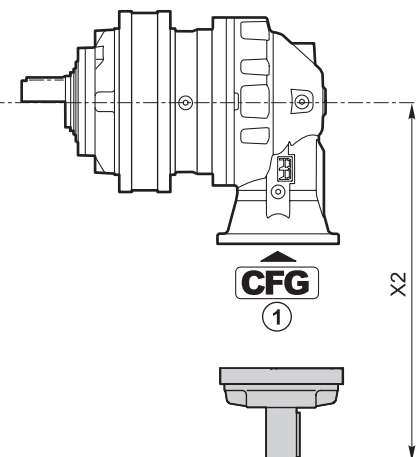

	CFG ①		code	X2
RR30000 A4(A)	—	P65CF	154-2404	600
RR30000 A4(B)	—	P65CF	154-2404	667
RR30000 A4(C)	—	P100SF-1	154F3322	791.5

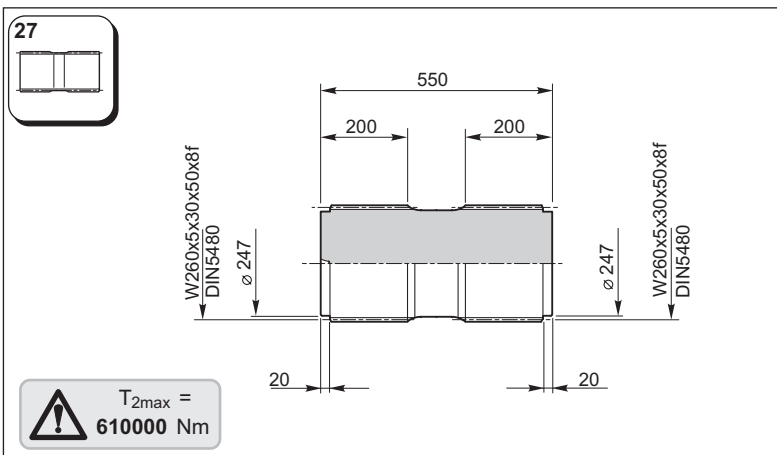
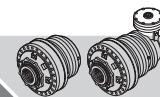

Materiale / Material / Material / Matériau / Material / Material:
Acciaio / Steel / Stahl / Acier / Acero / Aço
EN 10083-1-42CrMo4+QT (1.7225)

154F6044

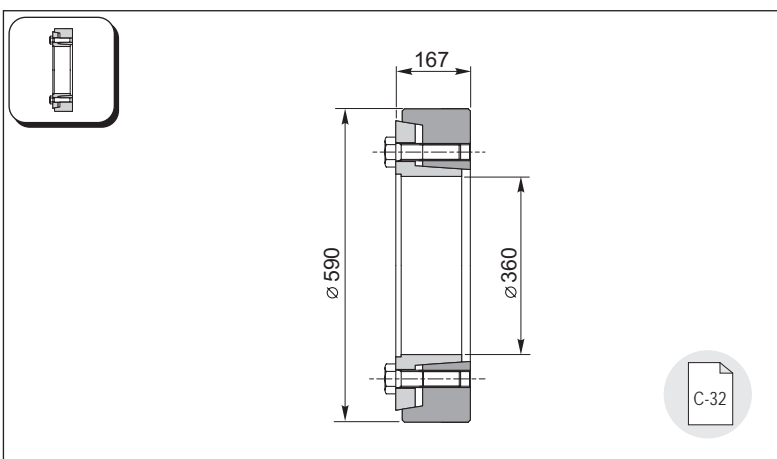

154F6072

**ATTENZIONE**

Il valore di T_{2max} indicato costituisce una limitazione del valore relativo al riduttore, riportato nella tabella dei dati tecnici per ciascuna grandezza.

ATTENTION

Le valeur de T_{2max} indiquée représente une restriction de la valeur relative au réducteur et indiquée sur le tableau des caractéristiques techniques pour chaque grandeur.

ATTENTION

The T_{2max} value indicated is a limit of the reduction gear value, given in the technical data table for each size.

ATENCIÓN

El valor de T_{2max} indicado constituye una limitación del valor referente al reductor, indicado en la tabla de los datos técnicos para cada talla.

ACHTUNG!

Der angegebene Wert T_{2max} stellt eine Einschränkung vom entsprechenden Wert am Untersetzungsgetriebe dar, der in der Tabelle mit den technischen Daten für jede Größe angegeben ist.

ATENÇÃO

O valor T_{2max} indicado representa uma limitação do valor relativo ao redutor, indicado na tabela dos dados técnicos para cada grandeza.



RR40000

IT EN DE FR ES PT

RR40000 L.. .. **i**

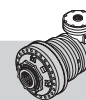

	i	T ₂ [Nm]						n _{1max} [min ⁻¹]	T _{2max} [Nm]	P _t [kW]
		n ₂ x h								
1/...		10000 (10 ⁴)	25000 (2.5 · 10 ⁴)	50000 (5 · 10 ⁴)	100000 (10 ⁵)	500000 (5 · 10 ⁵)	1000000 (10 ⁶)			
RR40000 L1	4.17	469980	433330	427360	407460	280010	227440	300	790000	236
	4.84	451820	412310	368820	350180	275270	223590	300	790000	236
	5.87	383530	325990	293510	281290	254840	219030	300	790000	236
RR40000 L2	17.42	469980	433330	427360	407460	271800	220770	500	790000	143
	20.21	469980	433330	427360	407460	267160	217000	500	790000	143
	24.49	422820	398500	381910	366020	261750	212610	500	790000	143
	28.41	451820	412310	368820	350180	290420	235900	500	790000	143
	34.42	383530	325990	293510	281290	254840	244230	500	790000	143
RR40000 L3	72.72	469980	433330	427360	404420	249540	202690	1000	790000	103
	84.36	469980	433330	427360	396370	244580	198660	1000	790000	103
	102.21	469980	433330	427360	388240	239560	194580	1000	790000	103
	118.57	469980	433330	427360	407460	265800	215900	1000	790000	103
	143.66	422820	398500	381910	366020	261750	212610	1000	790000	103
	166.65	451820	412310	368820	350180	290420	235900	1000	790000	103
	201.92	383530	325990	293510	281290	254840	244230	1000	790000	103
RR40000 L4	283.59	469980	433330	427360	404420	249540	202690	2000	790000	81
	328.99	469980	433330	427360	396370	244580	198660	2000	790000	81
	372.16	469980	433330	427360	396370	244580	198660	2000	790000	81
	398.61	469980	433330	427360	388240	239560	194580	2000	790000	81
	456.13	469980	433330	427360	404420	249540	202690	2000	790000	81
	503.29	469980	433330	427360	407460	267160	217000	2000	790000	81
	529.15	469980	433330	427360	396370	244580	198660	2000	790000	81
	609.78	469980	433330	427360	407460	265800	215900	2000	790000	81
	641.11	469980	433330	427360	388240	239560	194580	2000	790000	81
	743.75	469980	433330	427360	407460	265800	215900	2000	790000	81
	901.12	422820	398500	381910	366020	261750	212610	2000	790000	81
	1045.38	451820	412310	368820	350180	290420	235900	2000	790000	81
	1266.57	383530	325990	293510	281290	254840	244230	2000	790000	81

RR40000 A.. .. **i**

i	T ₂ [Nm]						n _{1max} [min ⁻¹]	T _{2max} [Nm]	P _t [kW]	
	n ₂ x h									
	10000 (10 ⁴)	25000 (2.5 · 10 ⁴)	50000 (5 · 10 ⁴)	100000 (10 ⁵)	500000 (5 · 10 ⁵)	1000000 (10 ⁶)				
RR40000 A4 (A)	198.32	240420	182640	148350	120490	74350	60390	2500	790000	84
	230.06	266750	202640	164600	133690	82490	67010	2500	790000	84
	278.74	305110	231780	188270	152920	94360	76640	2500	790000	84
	323.37	338540	257170	208890	169670	104690	85040	2500	790000	84
	391.79	387220	294150	238930	194070	119750	97260	2500	790000	84
	454.51	429630	326370	265100	215330	132860	107920	2500	790000	84
	550.68	383530	325990	293510	246290	151970	123440	2500	790000	84
	666.33	383530	325990	291930	237120	146310	118840	2500	790000	84
	785.24	383530	325990	275540	223810	138100	112170	2500	790000	84
(B)	201.37	285490	216870	176160	143080	88290	71710	2500	790000	86
	233.60	316760	240630	195450	158760	97960	79570	2500	790000	86
	283.03	362310	275230	223560	181590	112040	91010	2500	790000	86
	328.34	402000	305380	248050	201480	124320	100980	2500	790000	86
	397.82	422820	349300	283720	230450	142190	115500	2500	790000	86
	461.50	451820	387560	314790	255690	157770	128150	2500	790000	86
	559.16	383530	325990	293510	281290	180460	146580	2500	790000	86
	639.41	383530	325990	293510	281290	182730	148420	2500	790000	86
	826.03	383530	325990	293510	281290	181630	147530	2500	790000	86
(C)	178.99	469980	433330	373160	303100	187020	151910	2000	790000	93
	207.65	469980	433330	414040	336300	207510	168550	2000	790000	93
	251.59	469980	433330	427360	384660	237350	192790	2000	790000	93
	291.86	469980	433330	427360	407460	263350	213910	2000	790000	93
	375.47	469980	433330	427360	407460	263120	213720	2000	790000	93
	452.72	469980	433330	427360	407460	259730	210970	2000	790000	93
	548.51	422820	398500	381910	366020	261750	212610	2000	790000	93
	636.32	451820	412310	368820	350180	290420	235900	2000	790000	93
	770.96	383530	325990	293510	281290	254840	244230	2000	790000	93



RR40000

IT EN DE FR ES PT

RR40000 L.. .. i

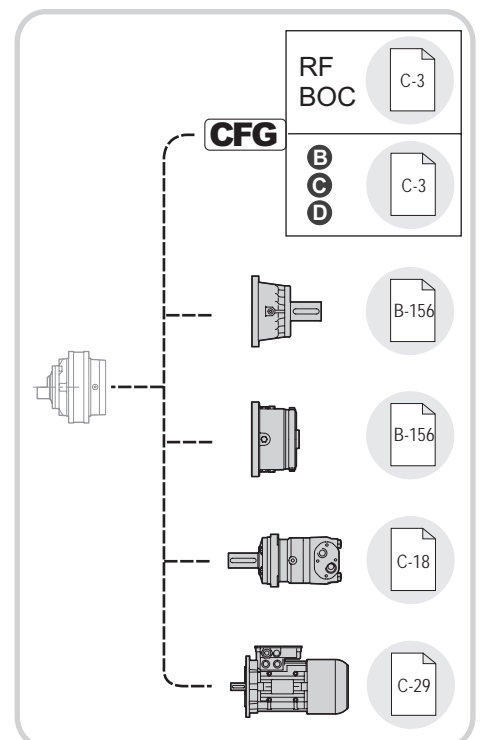
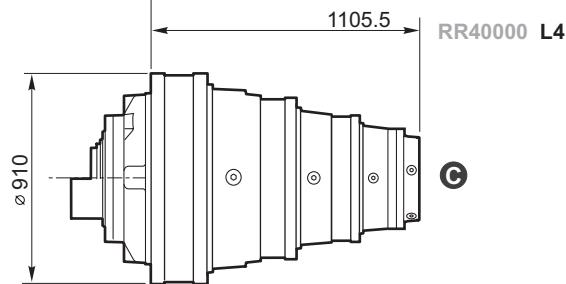
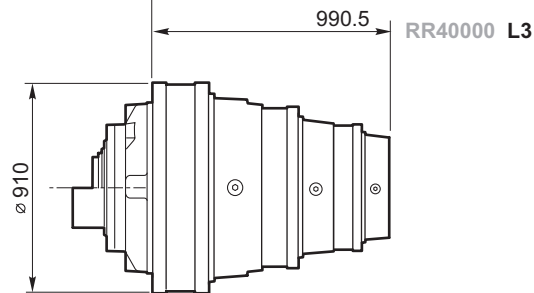
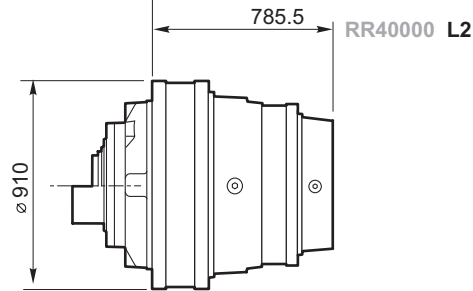
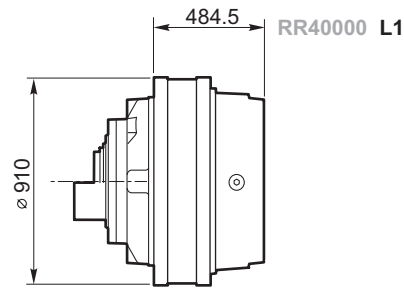

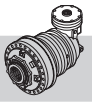

RR40000 A.. .. i

A4(..)

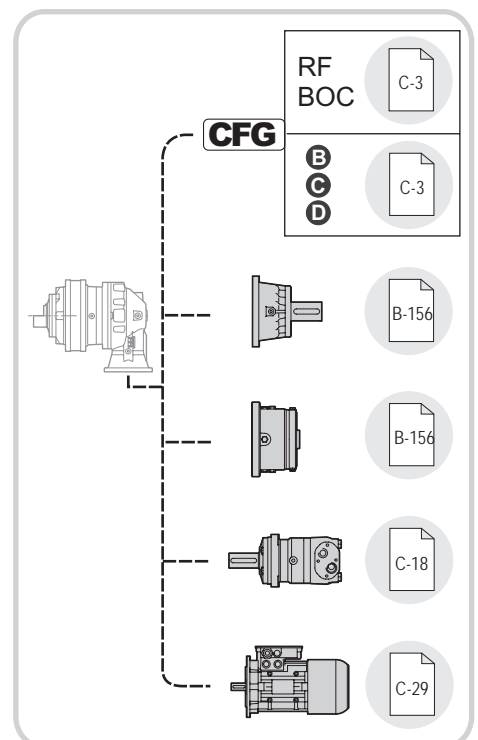
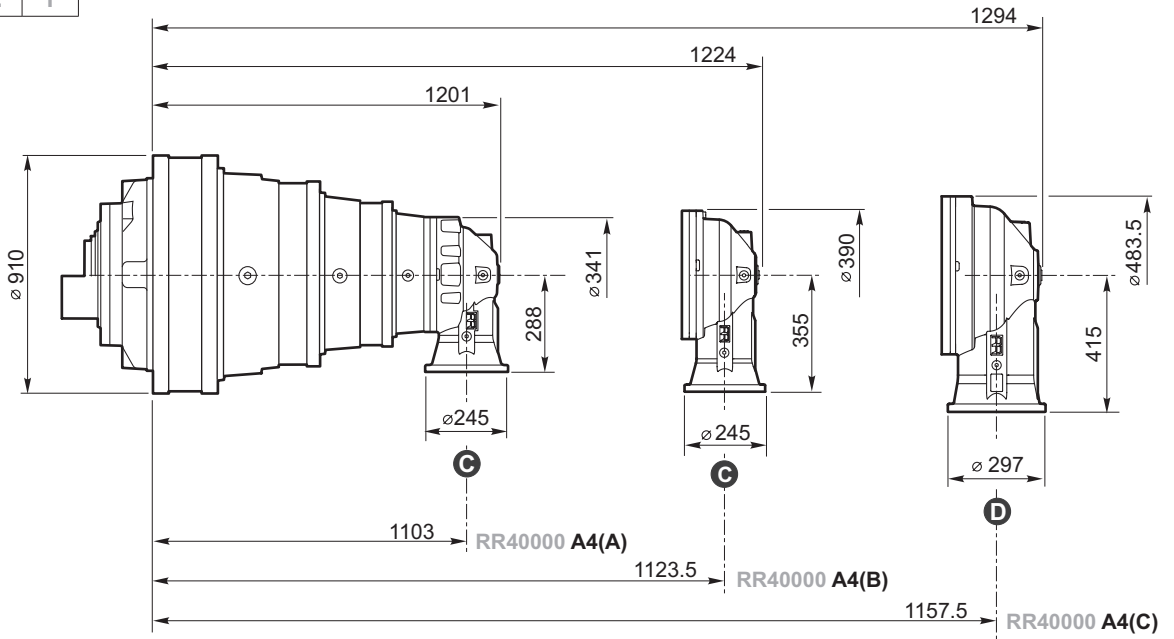

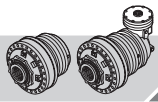

RR40000

IT EN DEFRES PT

RR40000	L..	FS	i
RR40000	A..		i

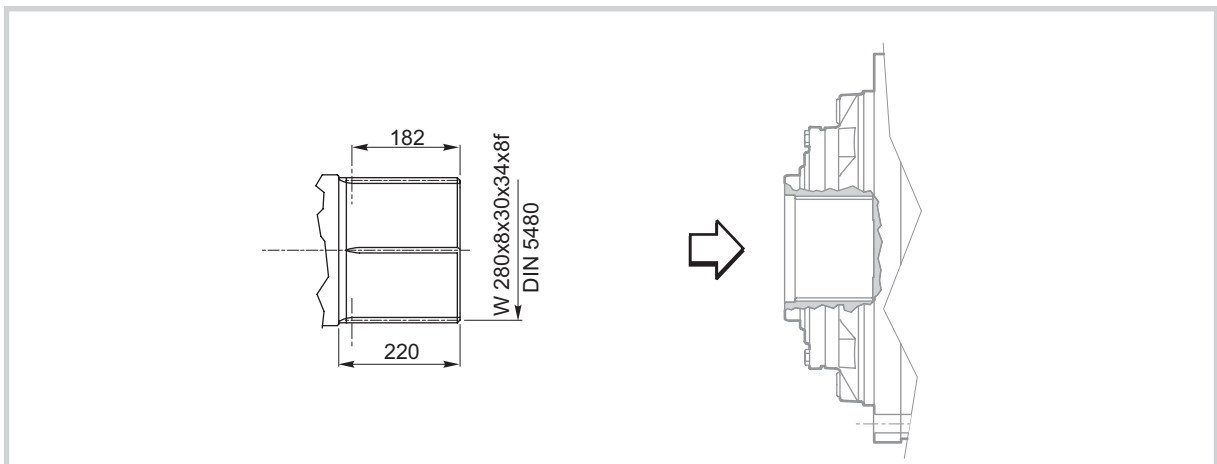
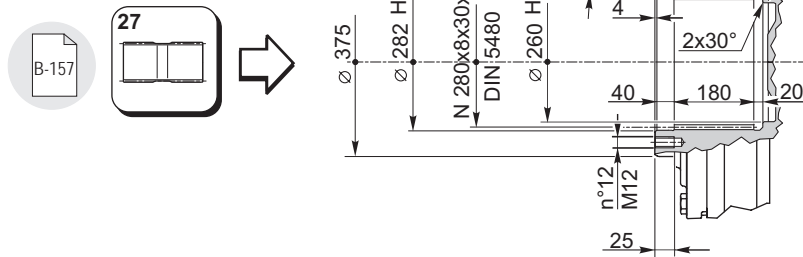
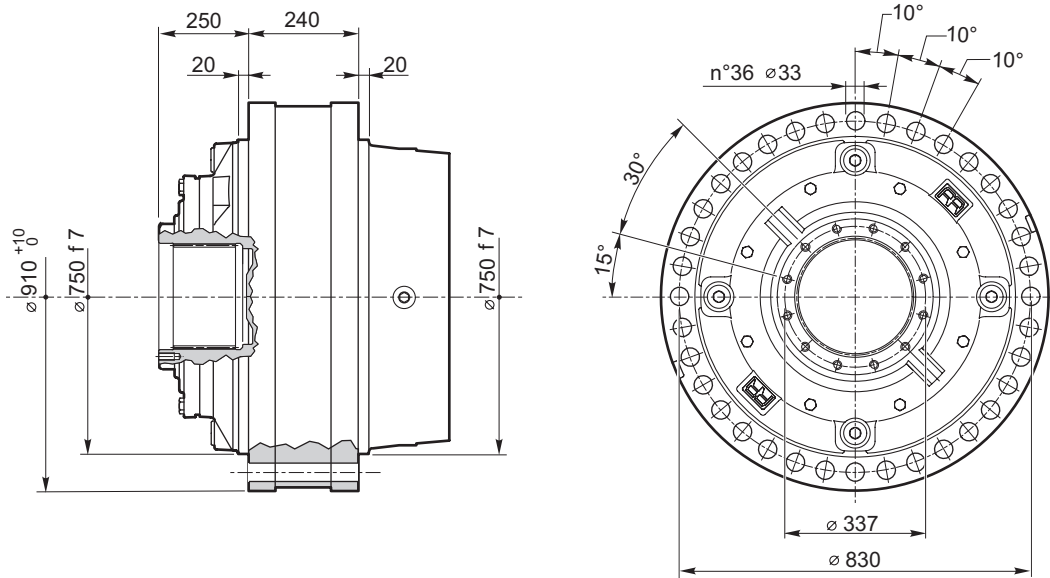

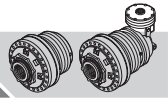

RR40000	L..	MH	i
RR40000	A..		i

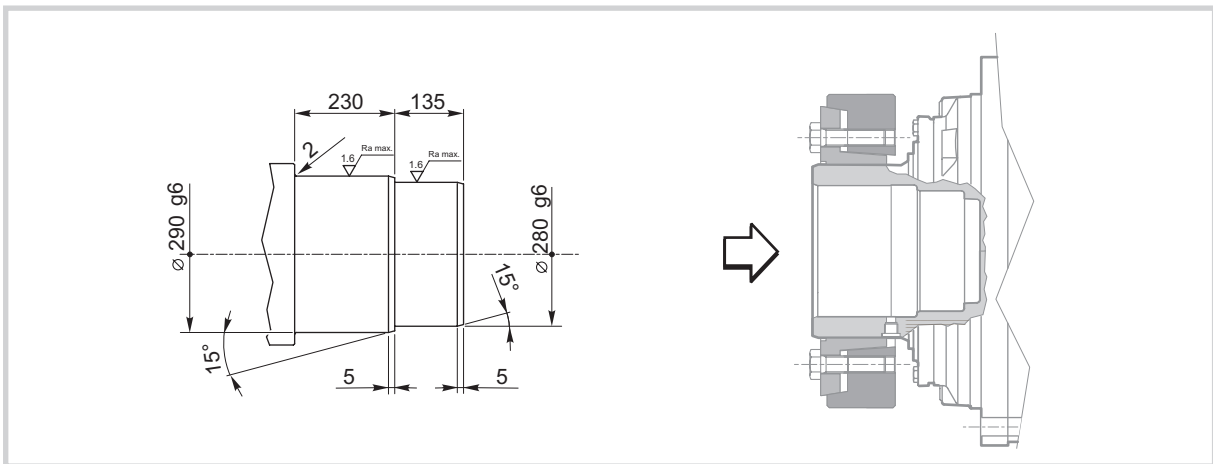
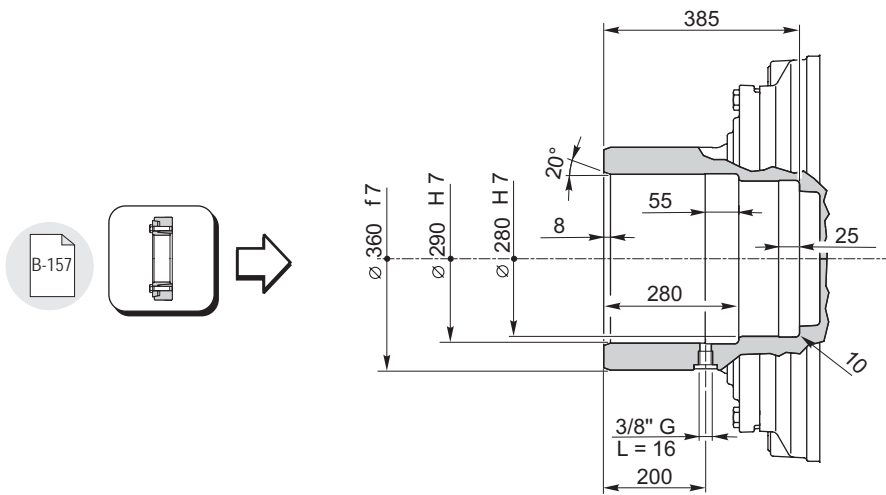
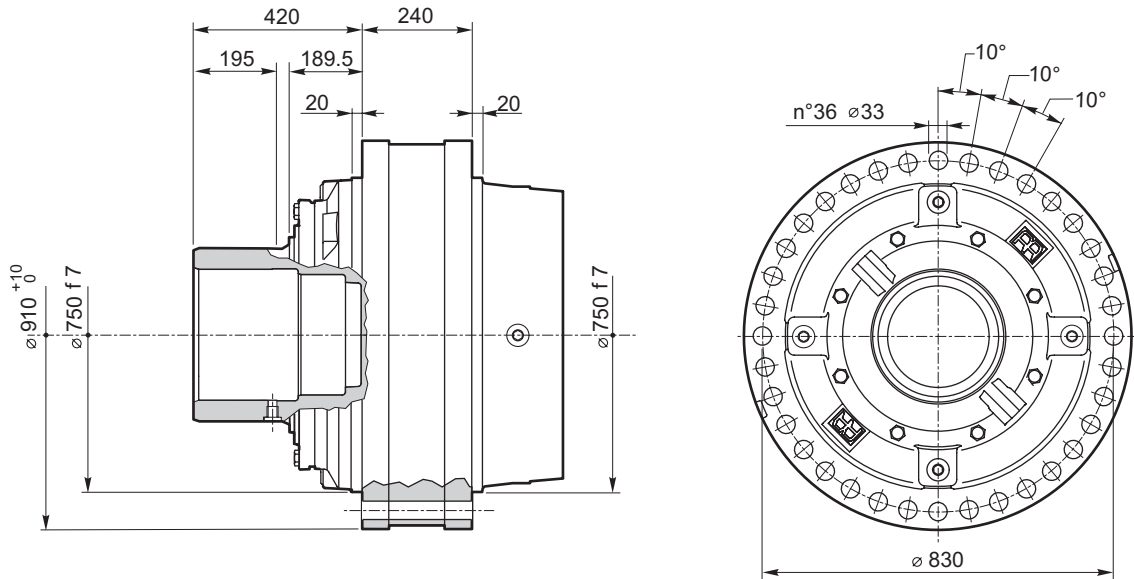

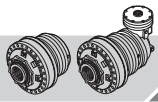

RR40000

IT EN DE FR ES PT

RF170-290



C-12

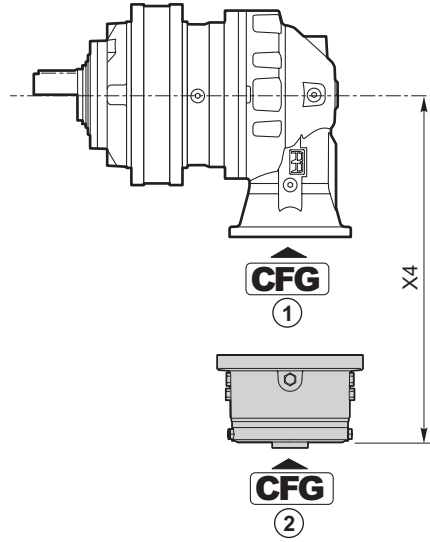
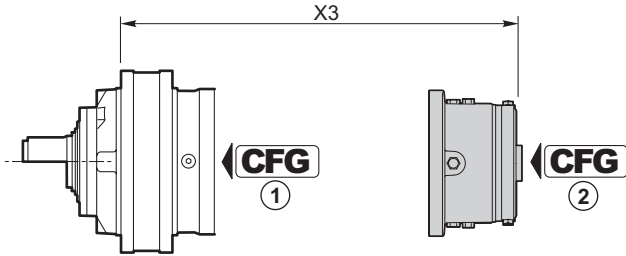

RF170-290	CFG ①	T _f [Nm]	CFG ②		
			C		
			code	X3	X4
RR40000 L4	RF	1700	154B9766M2	1302.5	—
		2000	154B9767M2		
		2300	154B9768M2		
		2900	154B9769M2		
RR40000 A4(A)	—	1700	154B9766M3	—	485
		2000	154B9767M3		
		2300	154B9768M3		
		2900	154B9769M3		
RR40000 A4(B)	—	1700	154B9766M3	—	552
		2000	154B9767M3		
		2300	154B9768M3		
		2900	154B9769M3		

CFG	
RF BOC	C-3
B C D	C-3

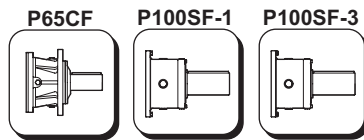

C-10

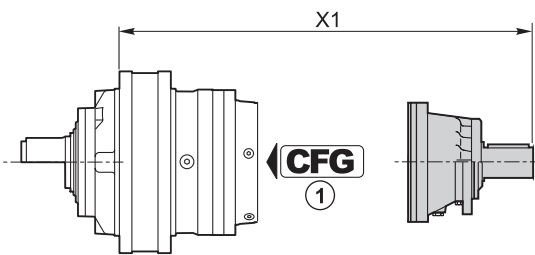

	CFG ①		code	X1
RR40000 L3	—	P100SF-3	154F3324	1367.5
RR40000 L4	—	P65CF	154-2404	1417.5

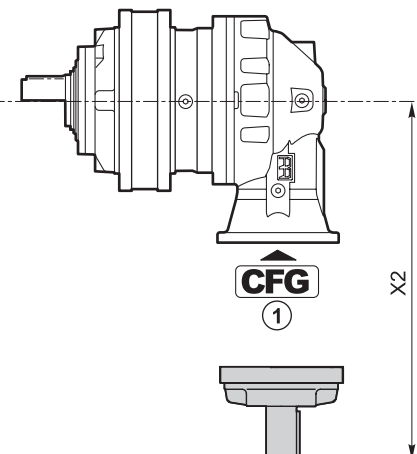

	CFG ①		code	X2
RR40000 A4(A)	—	P65CF	154-2404	600
RR40000 A4(B)	—	P65CF	154-2404	667
RR40000 A4(C)	—	P100SF-1	154F3322	791.5

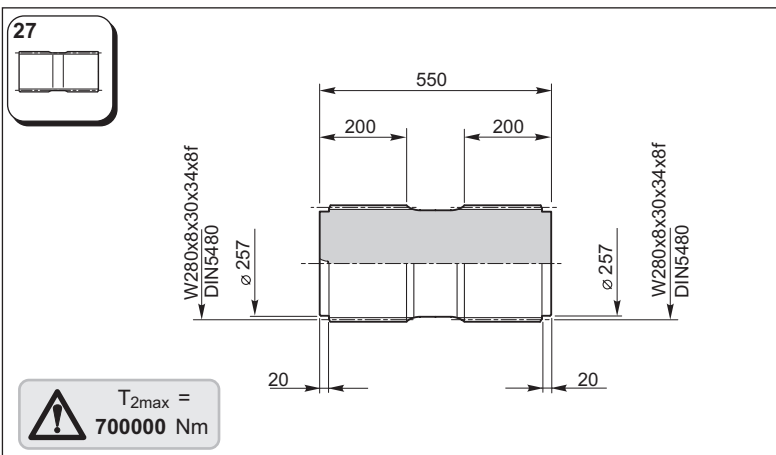
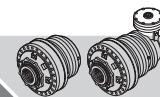

Materiale / Material / Material / Matériau / Material / Material:
Acciaio / Steel / Stahl / Acier / Acero / Aço
EN 10083-1-42CrMo4+QT (1.7225)

154F6045

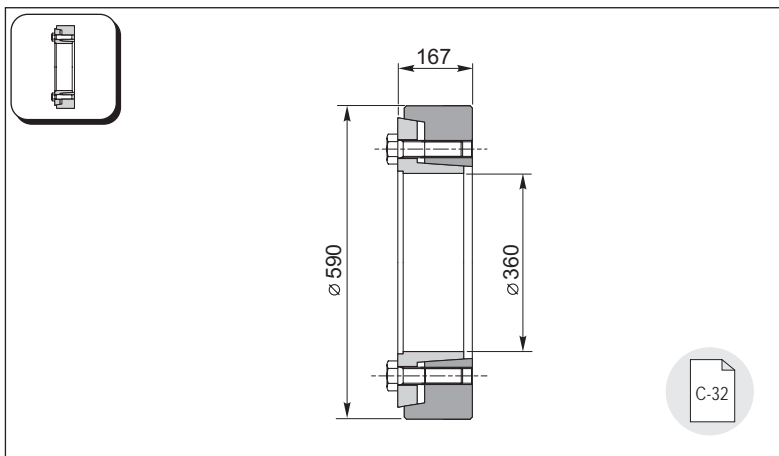

154F6072

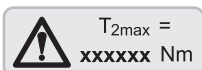
**ATTENZIONE**

Il valore di T_{2max} indicato costituisce una limitazione del valore relativo al riduttore, riportato nella tabella dei dati tecnici per ciascuna grandezza.

ATTENTION

Le valeur de T_{2max} indiquée représente une restriction de la valeur relative au réducteur et indiquée sur le tableau des caractéristiques techniques pour chaque grandeur.

ATTENTION

The T_{2max} value indicated is a limit of the reduction gear value, given in the technical data table for each size.

ATENCIÓN

El valor de $T_{2m\acute{a}x}$ indicado constituye una limitación del valor referente al reductor, indicado en la tabla de los datos técnicos para cada talla.

ACHTUNG!

Der angegebene Wert T_{2max} stellt eine Einschränkung vom entsprechenden Wert am Untersetzungsgetriebe dar, der in der Tabelle mit den technischen Daten für jede Größe angegeben ist.

ATENÇÃO

O valor T_{2max} indicado representa uma limitação do valor relativo ao redutor, indicado na tabela dos dados técnicos para cada grandeza.



RR55000

IT EN DE FR ES PT

RR55000 L.. .. **i**



	i	T ₂ [Nm]						n _{1max} [min ⁻¹]	T _{2max} [Nm]	P _t [kW]
		n ₂ x h								
1/...		10000 (10 ⁴)	25000 (2.5 · 10 ⁴)	50000 (5 · 10 ⁴)	100000 (10 ⁵)	500000 (5 · 10 ⁵)	1000000 (10 ⁶)			
RR55000 L1	4.17	675660	622480	613900	596580	386470	313910	300	950000	280
	4.84	648310	591060	536410	509350	379820	308510	300	950000	280
	5.87	556900	473810	426850	409080	370610	302250	300	950000	280
RR55000 L2	17.42	675660	622480	613900	596580	380100	308740	500	950000	170
	20.21	675660	622480	613900	596580	373580	303440	500	950000	170
	24.49	614160	578850	554750	531650	365980	297270	500	950000	170
	28.41	648310	591060	536410	509350	379820	308510	500	950000	170
	34.42	556900	473810	426850	409080	370610	302250	500	950000	170
RR55000 L3	72.72	675660	622480	599370	486840	300400	244000	1000	950000	123
	84.36	675660	622480	589110	478500	295250	239820	1000	950000	123
	102.21	675660	622480	577200	468830	289280	234970	1000	950000	123
	118.57	675660	622480	613900	520190	320970	260710	1000	950000	123
	143.66	614160	578850	554750	531650	365980	297270	1000	950000	123
	166.65	648310	591060	536410	509350	379820	308510	1000	950000	123
	201.92	556900	473810	426850	409080	370610	302250	1000	950000	123
RR55000 L4	290.86	675660	622480	599370	486840	300400	244000	2000	950000	97
	337.43	675660	622480	613900	540170	333300	270730	2000	950000	97
	391.45	675660	622480	613900	530920	327600	266090	2000	950000	97
	425.11	675660	622480	599370	486840	300400	244000	2000	950000	97
	460.52	675660	622480	613900	530920	327600	266090	2000	950000	97
	493.16	675660	622480	613900	540170	333300	270730	2000	950000	97
	557.97	675660	622480	613900	520190	320970	260710	2000	950000	97
	597.51	675660	622480	577200	468830	289280	234970	2000	950000	97
	693.17	675660	622480	613900	520190	320970	260710	2000	950000	97
	839.84	614160	578850	554750	531650	365980	297270	2000	950000	97
	974.29	648310	591060	536410	509350	379820	308510	2000	950000	97
	1180.44	556900	473810	426850	409080	370610	302250	2000	950000	97

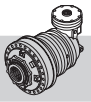

RR55000 A.. .. **i**



i	T ₂ [Nm]						n _{1max} [min ⁻¹]	T _{2max} [Nm]	P _t [kW]	
	n ₂ x h									
1/...	10000 (10 ⁴)	25000 (2.5 · 10 ⁴)	50000 (5 · 10 ⁴)	100000 (10 ⁵)	500000 (5 · 10 ⁵)	1000000 (10 ⁶)				
RR55000 A4	178.99	604770	459420	373160	303100	187020	151910	2000	950000	110
	207.65	671010	509740	414040	336300	207510	168550	2000	950000	110
	251.59	675660	583040	473580	384660	237350	192790	2000	950000	110
	291.86	675660	622480	525450	426800	263350	213910	2000	950000	110
	353.62	614160	578850	554750	488170	301220	244670	2000	950000	110
	410.23	648310	591060	536410	509350	334220	271470	2000	950000	110
	527.74	648310	591060	536410	509350	333920	271230	2000	950000	110
	636.32	648310	591060	536410	509350	329630	267740	2000	950000	110
	770.96	556900	473810	426850	409080	370610	302250	2000	950000	110



RR55000

IT EN DE FR ES PT

RR55000 L.. .. i

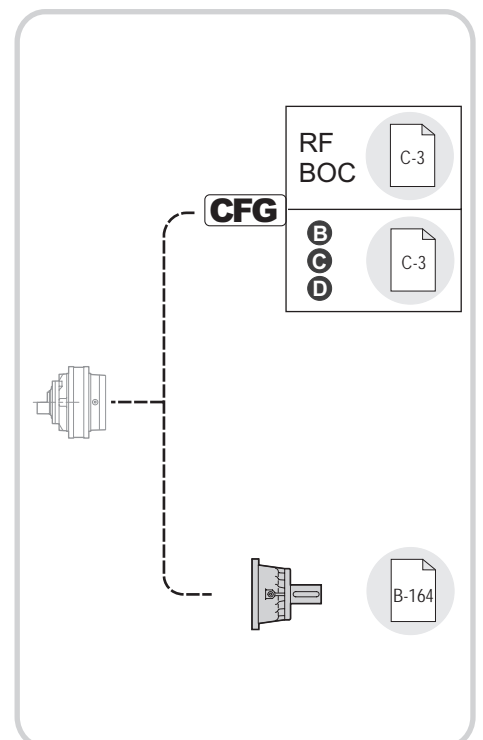
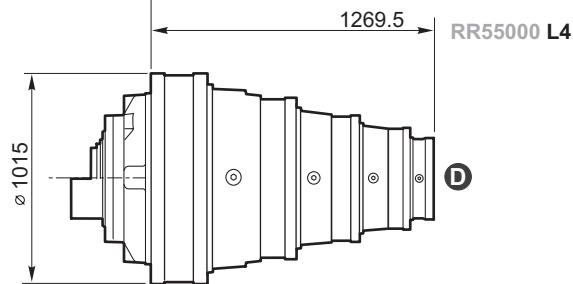
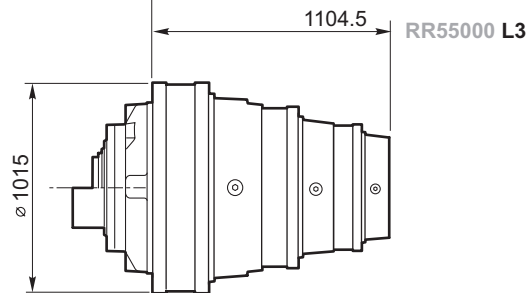
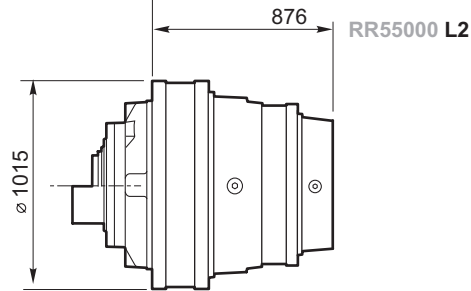
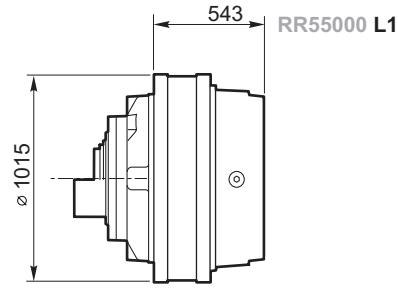

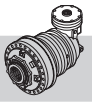

RR55000 A.. .. i

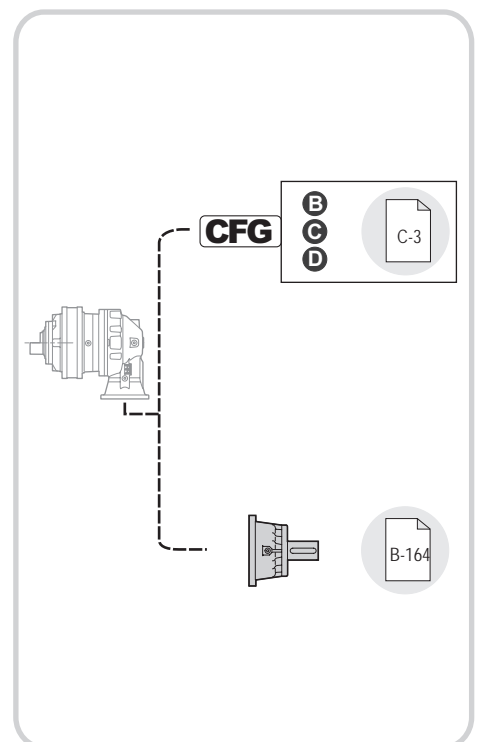
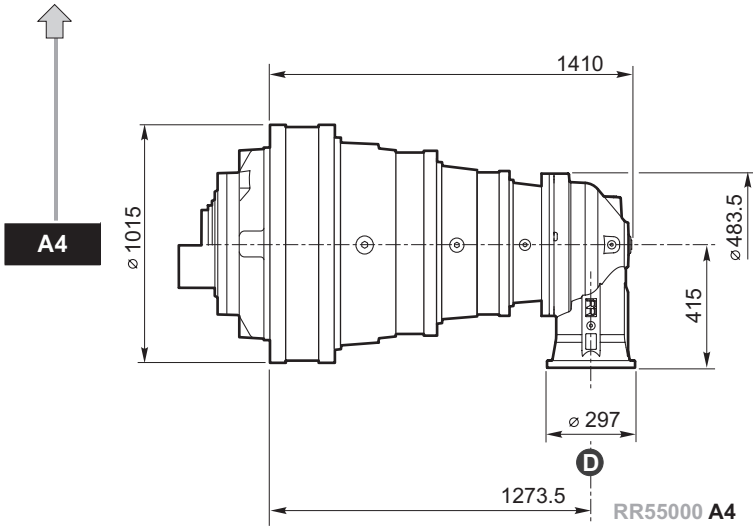

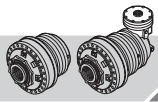

RR55000

IT EN DEFRES PT

RR55000	L..	FS	i
RR55000	A..		i

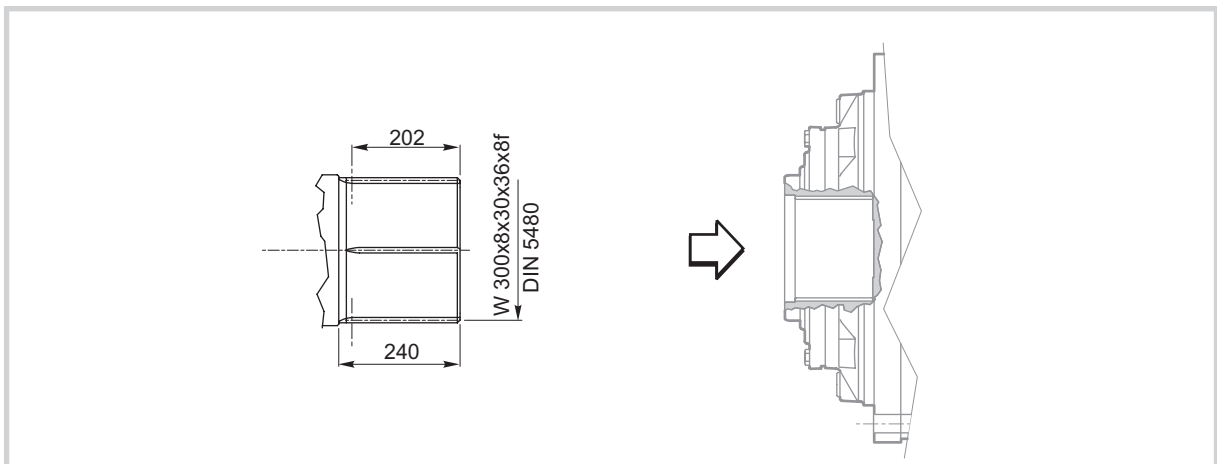
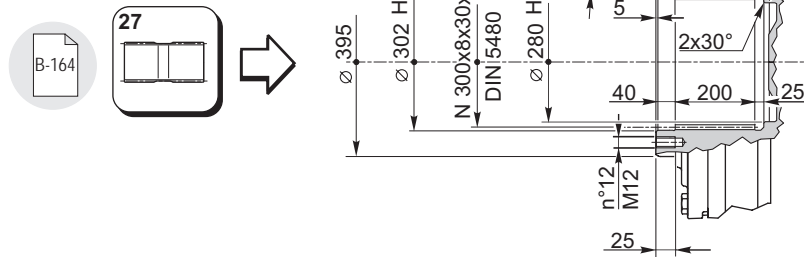
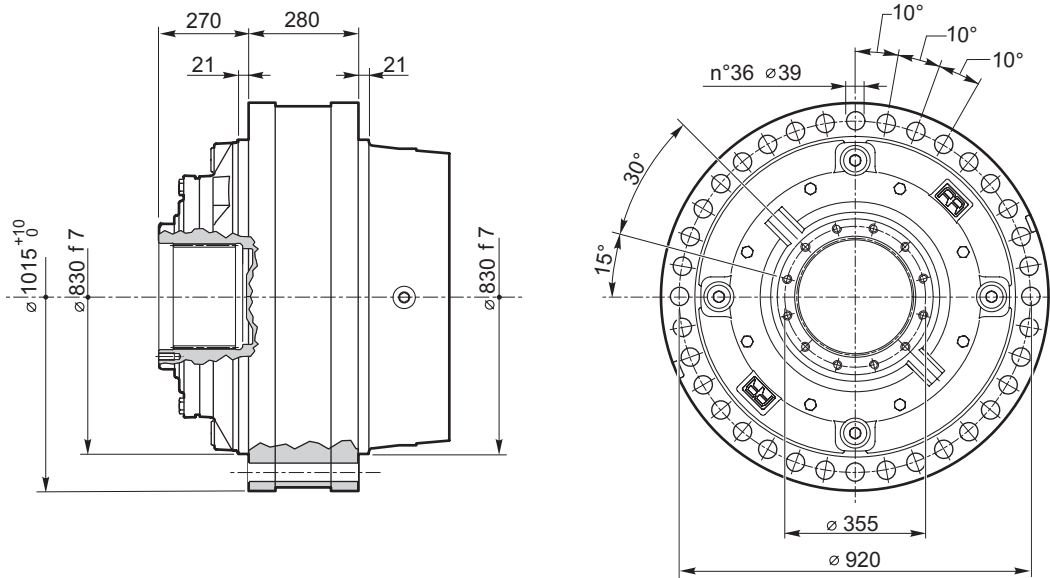

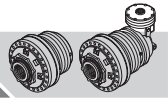

RR55000	L..	MH	i
RR55000	A..		i

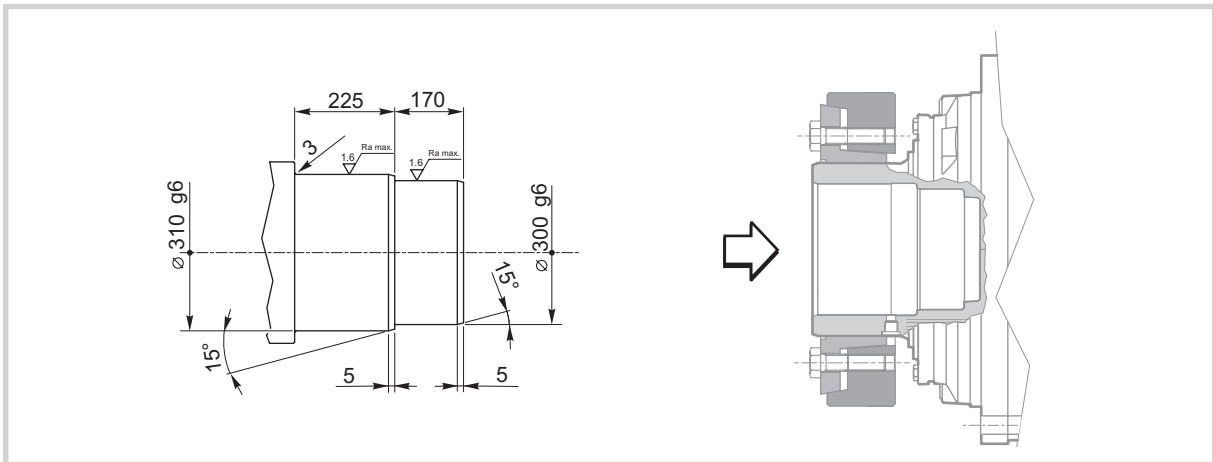
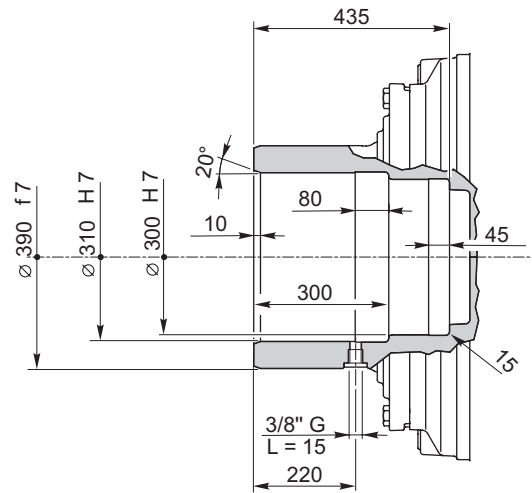
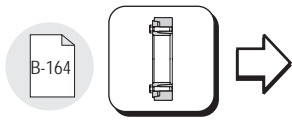
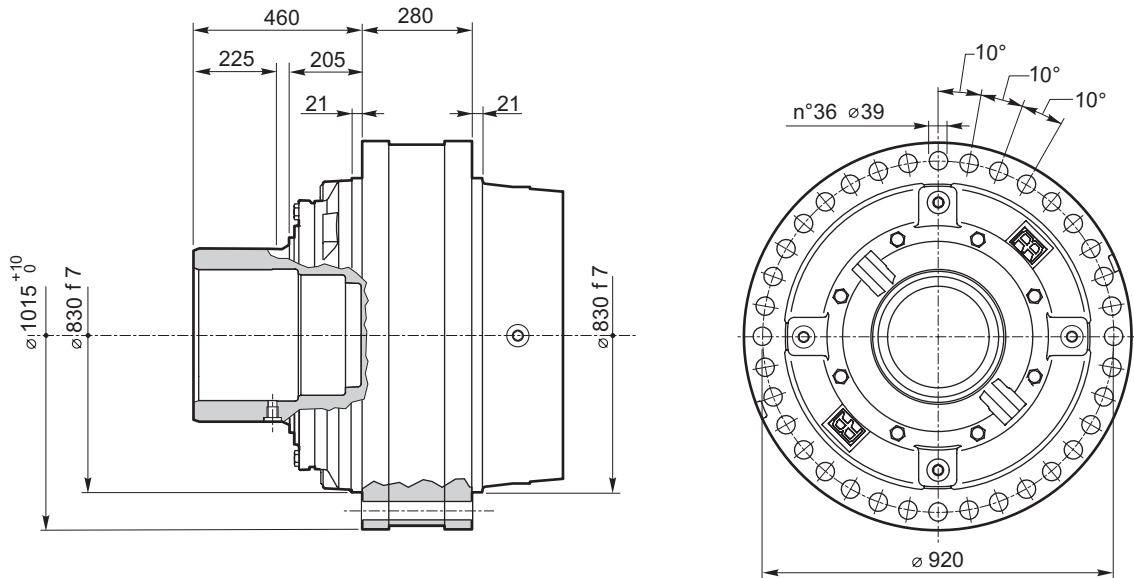

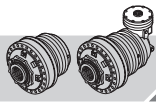

RR55000

IT EN DE FR ES PT

P100SF-1

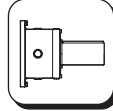

C-10

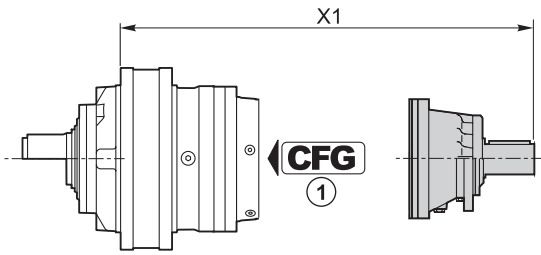

CFG	
RF	C-3
BOC	C-3
B	
G	
D	

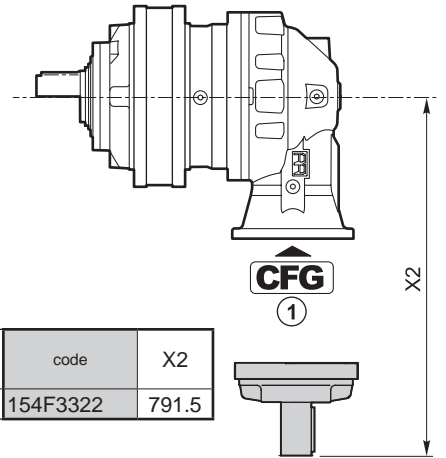

	CFG		code	X1
RR55000 L4	①	P100SF-1	154F3322	1646

	CFG		code	X2
RR55000 A4	①	P100SF-1	154F3322	791.5

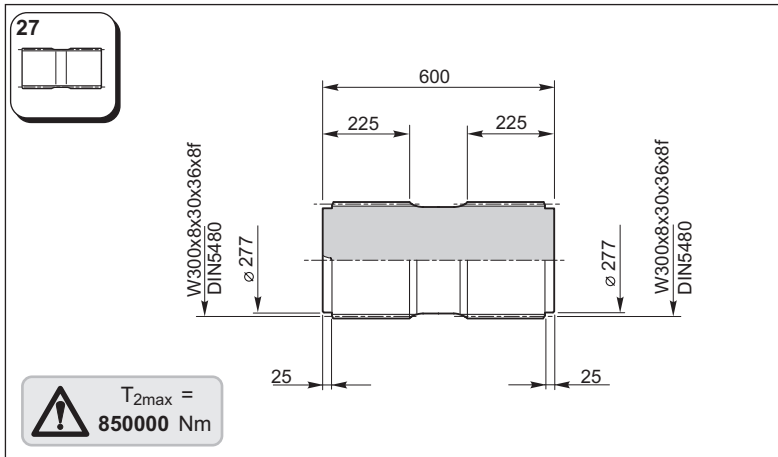

Materiale / Material / Material / Matériau / Material / Material:
 Acciaio / Steel / Stahl / Acier / Acero / Aço
 EN 10083-1-42CrMo4+QT (1.7225)

T_{2max} =
 xxxxxx Nm

ATTENZIONE

Il valore di T_{2max} indicato costituisce una limitazione del valore relativo al riduttore, riportato nella tabella dei dati tecnici per ciascuna grandezza.

ATTENTION

The T_{2max} value indicated is a limit of the reduction gear value, given in the technical data table for each size.

ACHTUNG!

Der angegebene Wert T_{2max} stellt eine Einschränkung vom entsprechenden Wert am Untersetzungsgetriebe dar, der in der Tabelle mit den technischen Daten für jede Größe angegeben ist.

ATTENTION

Le valeur de T_{2max} indiquée représente une restriction de la valeur relative au réducteur et indiquée sur le tableau des caractéristiques techniques pour chaque grandeur.

ATENCIÓN

El valor de T_{2máx} indicado constituye una limitación del valor referente al reductor, indicado en la tabla de los datos técnicos para cada talla.

ATENÇÃO

O valor T_{2max} indicado representa uma limitação do valor relativo ao redutor, indicado na tabela dos dados técnicos para cada grandeza.

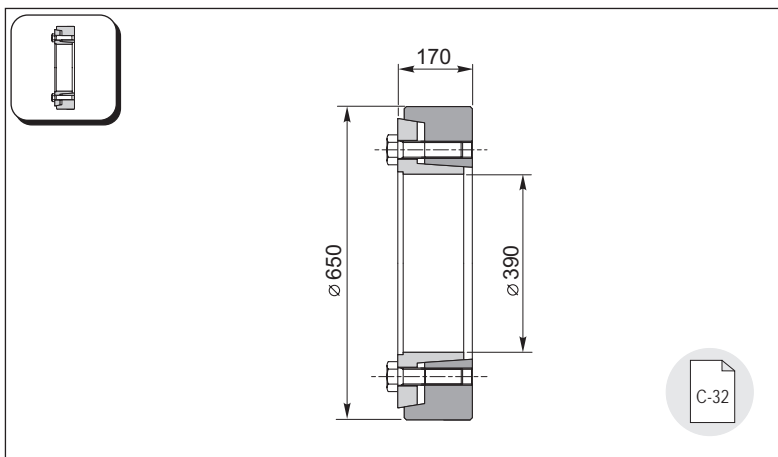

154F6073

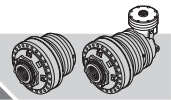

C

Configurazioni e accessori in ingresso, installazione
Input configurations and accessories, installation
Konfigurationen und Zubehör am Eingang, Installation
Configurations et accessoires à l'entrée, installation
Configuraciones y accesorios en entrada, instalación
Configurações e acessórios entrada, instalação

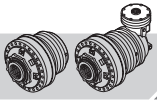

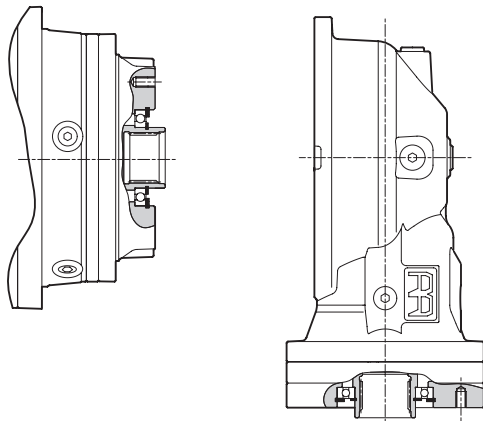
**Ingresso standard / Standard input / Standardeingang
Entrée standard / Entrada standard / Entrada padrão**
**B
C
D**

Dimensioni di ingresso per i tipi B, C, D riportate nel dettaglio nelle pagine seguenti.

Dimensions d'entrée pour les types B, C, D figurant dans le détail sur les pages suivantes.

Input dimensions for types B, C, D are detailed on the next pages.

Dimensiones de entrada para los tipos B, C, D indicadas detalladamente en las páginas siguientes.

Die Abmessungen vom Eingang für die Typen B, C und D sind detailliert auf den folgenden Seiten angegeben.

Dimensões de entrada para os tipos B, C, D indicadas detalhadamente nas páginas seguintes.

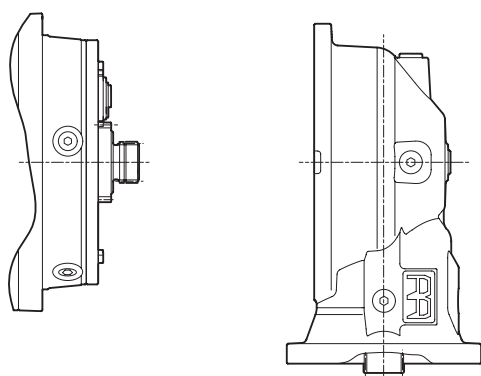
**Predisposizione RF / RF Setup / Auslegung RF
Préréglage RF / Predisposición RF / Predisposição RF**
(RF)

Entrata diretta in corona e pignone solare; dimensioni di ingresso variabili in base alla grandezza del riduttore, fornibili su richiesta. Consente il montaggio di freni, accoppiamenti motore ed altri accessori.

Entrée directe en couronne et pignon solaire; dimensions d'entrée variables en fonction de la grandeur du réducteur, communiquées sur simple demande. Elle permet de monter les freins, les accouplements moteur et d'autres accessoires.

Direct input in the crown and sun gears; input dimensions vary according to gear size, can be supplied on request. It allows brakes, motor couplings and other accessories to be mounted.

Entrada directa en corona y piñón solar; dimensiones de entrada variables según el tamaño del reductor, proporcionables a petición. Permite el montaje de frenos, acoplamiento motor y otros accesorios.

Direkter Eingang an Kranz und Planetenrad. Die Abmessungen vom Eingang variieren je nach Größe vom Untersetzungsgetriebe und sind auf Wunsch erhältlich. Erlaubt die Montage von Bremsen, Motorkupplungen und anderem Zubehör.

Entrada direta em coroa e pinhão solar; dimensões de entrada variáveis conforme a grandeza do reductor, fornecidos a pedido. Consente a montagem de freios, acoplamentos do motor e outros acessórios.

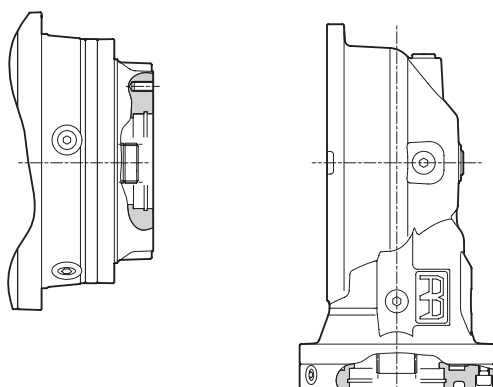
**Predisposizione BOC / BOC Setup / Auslegung BOC
Préréglage BOC / Predisposición BOC / Predisposição BOC**
(BOC)

Come ingresso standard ma con pignone solare; dimensioni di ingresso variabili in base alla grandezza del riduttore, fornibili su richiesta. Consente il montaggio di accoppiamenti motore ed altri accessori.

Comme entrée standard mais avec pignon solaire; dimensions d'entrée variables en fonction de la grandeur du réducteur, communiquées sur simple demande. Elle permet de monter les accouplements moteur et d'autres accessoires.

Like the standard input but with a sun gear; input dimensions vary according to gear size, can be supplied on request. It allows motor couplings and other accessories to be mounted.

Como entrada standard, pero con piñón solar; dimensiones de entrada variables según el tamaño del reductor, proporcionables a petición. Permite el montaje de acoplamiento motor y otros accesorios.

Wie Standardeingang, aber mit Planetenrad. Die Abmessungen vom Eingang variieren je nach Größe vom Untersetzungsgetriebe und sind auf Wunsch erhältlich. Erlaubt die Montage von Motorkupplungen und anderem Zubehör.

Como entrada padrão mas com pinhão solar; dimensões de entrada variáveis conforme a grandeza do reductor, fornecidos a pedido. Consente a montagem de acoplamentos do motor e outros acessórios.

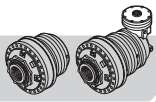

Ingresso standard / Standard input / Standardeingang
 Entrée standard / Entrada standard / Entrada padrão

B

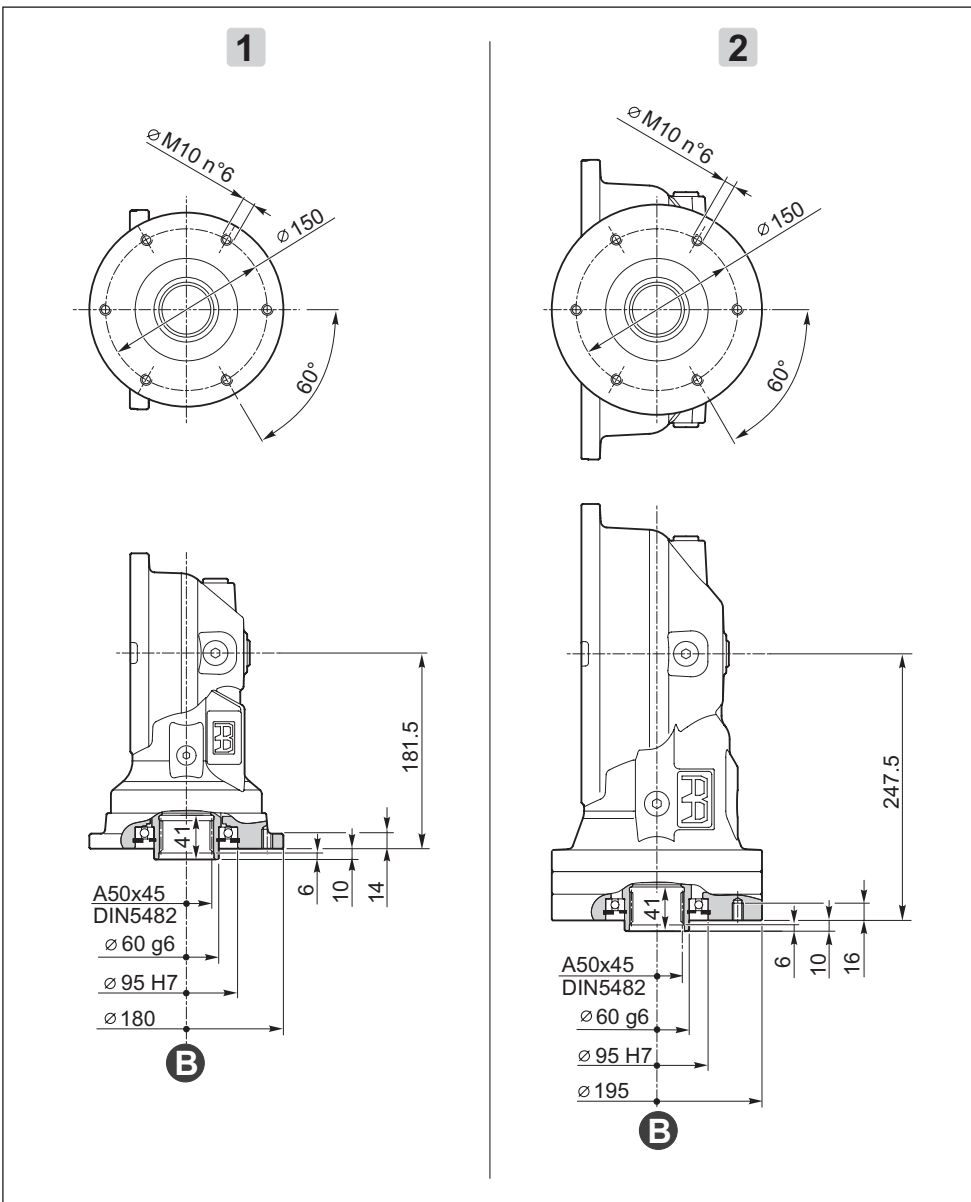
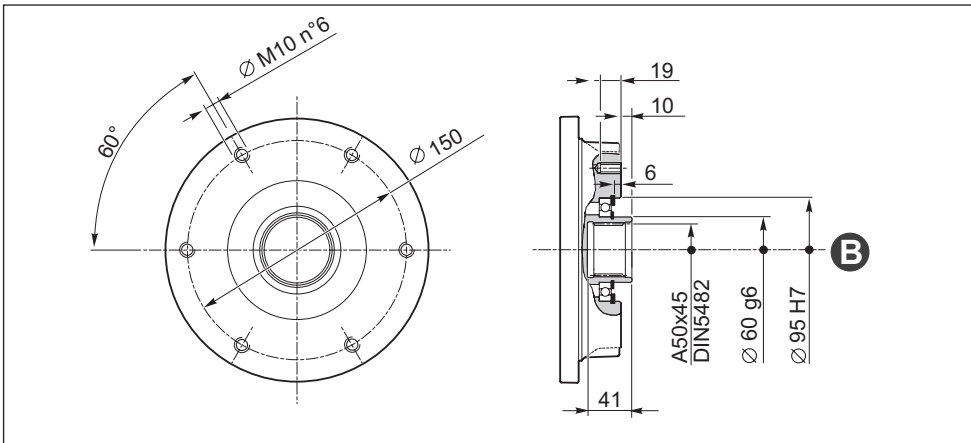

1

RR2500	A4
RR3200	—
RR4000	—
RR5200	—
RR6500	—
RR8000	—
RR10000	—
RR15000	—
RR20000	—
RR25000	—
RR30000	—
RR40000	—
RR55000	—

2

RR2500	A3
RR3200	A3(A)/A4
RR4000	A3(A)/A4
RR5200	A3(A)/A4
RR6500	A4
RR8000	A4(A)
RR10000	A4(A)
RR15000	A4(A)
RR20000	—
RR25000	—
RR30000	—
RR40000	—
RR55000	—

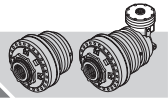

Ingresso standard / Standard input / Standardeingang
Entrée standard / Entrada standard / Entrada padrão

B

RF2

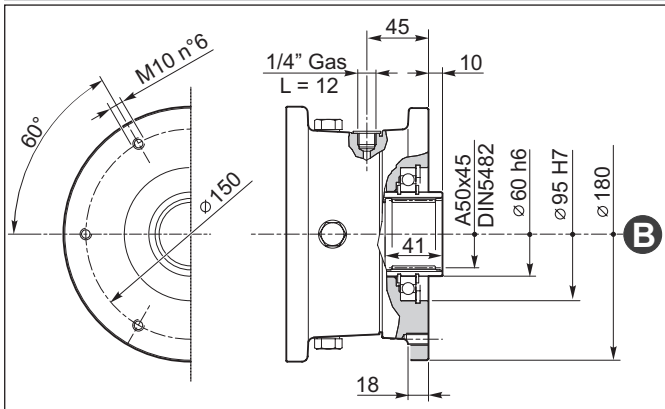

RF5

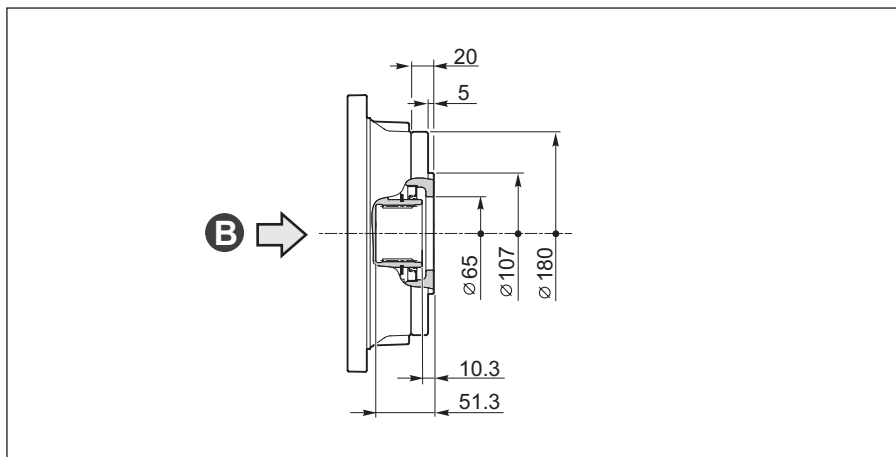
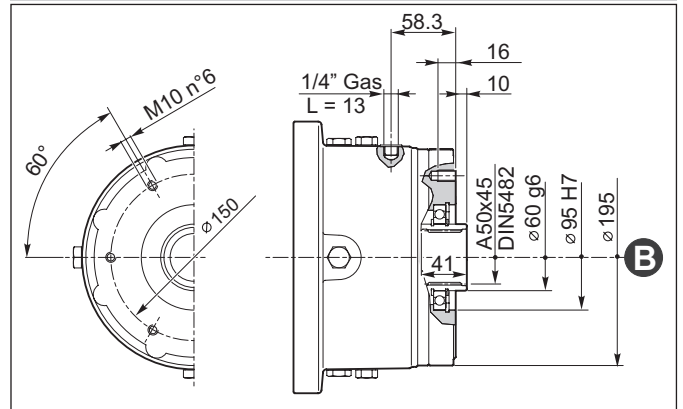

154-2300M324

Kit di chiusura per entrata tipo **(B)** completo di tenuta paraolio.

Closing kit for type **(B)** input, complete with oil seal.

Verschlussatz für Eingang Typ **(B)** komplett mit Ölabdichtung.

Kit de fermeture pour entrée type **B** avec joint étanche à l'huile.

Kit de cierre para entrada de tipo **(B)** completo de sello de aceite.

Kit de encerramento para entrada de tipo **B** munido de vedação para-óleo.

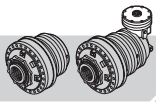

Ingresso standard / Standard input / Standardeingang
 Entrée standard / Entrada standard / Entrada padrão

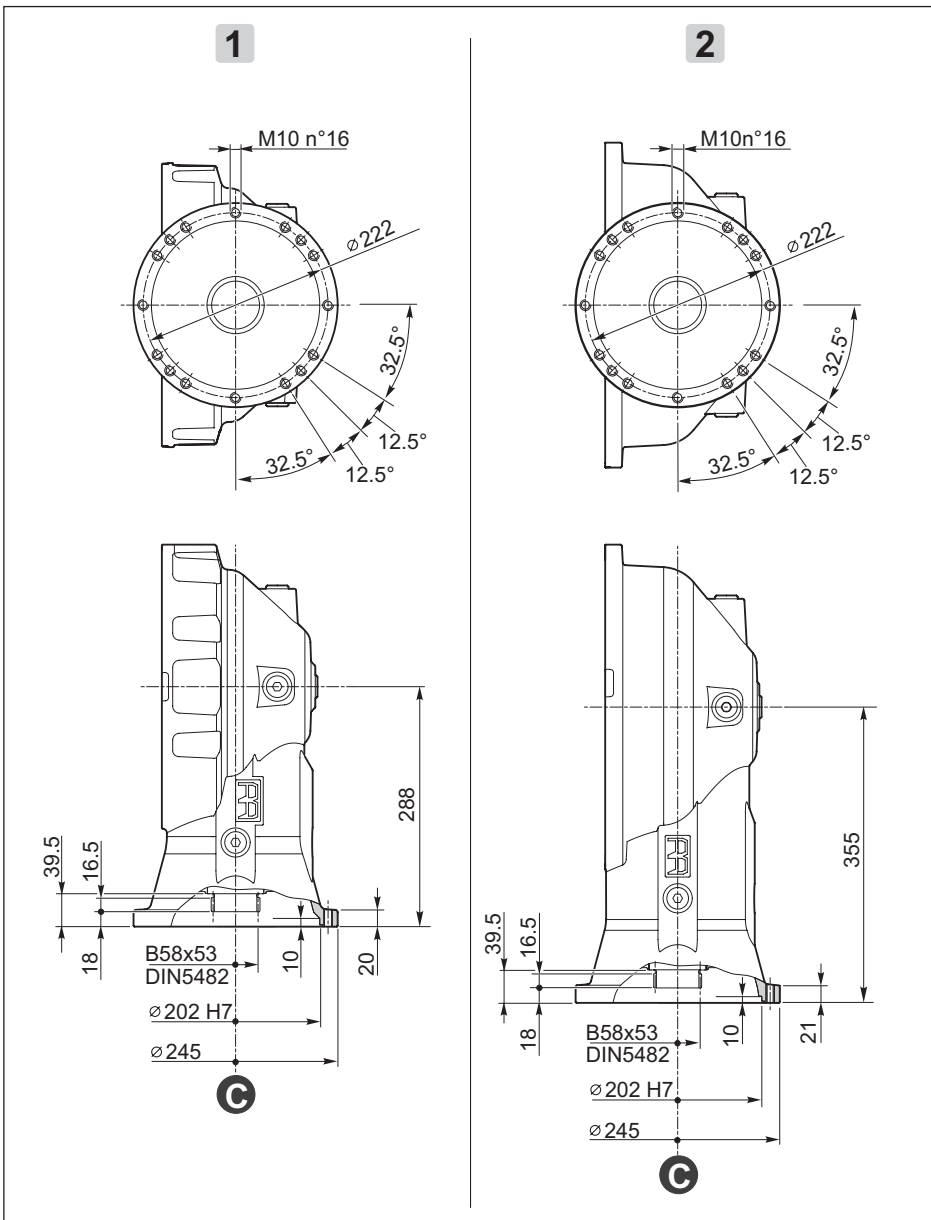
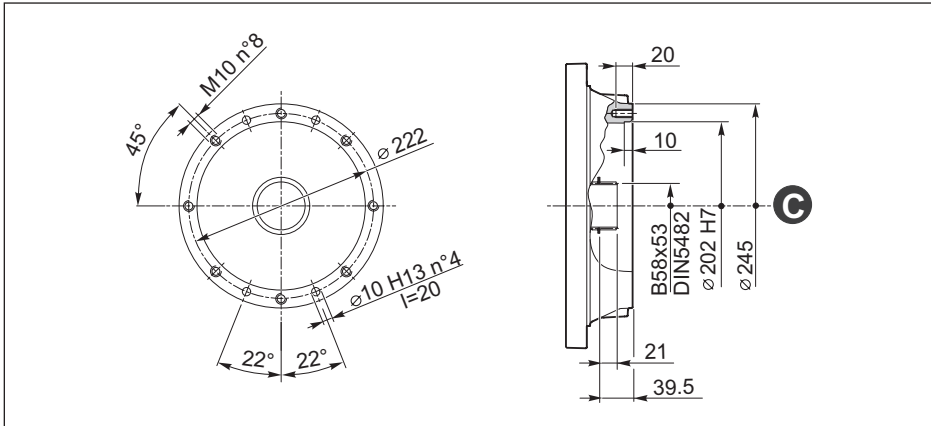

1

RR2500	A2(A)
RR3200	A2(A)/A3(B)
RR4000	A2(A)/A3(B)
RR5200	A2(A)/A3(B)
RR6500	A3(A)
RR8000	A3(A)/A4(B)
RR10000	A3(A)/A4(B)
RR15000	A3(A)/A4(B)
RR20000	A4(A)
RR25000	A4(A)
RR30000	A4(A)
RR40000	A4(A)
RR55000	—

2

RR2500	A2(B)
RR3200	A2(B)
RR4000	A2(B)
RR5200	A2(B)/A3(C)
RR6500	A3(B)
RR8000	A3(B)
RR10000	A3(B)
RR15000	A3(B)/A4(C)
RR20000	A4(B)
RR25000	A4(B)
RR30000	A4(B)
RR40000	A4(B)
RR55000	—



Ingresso standard / Standard input / Standerdeingang
Entrée standard / Entrada standard / Entrada padrão



RF170-290

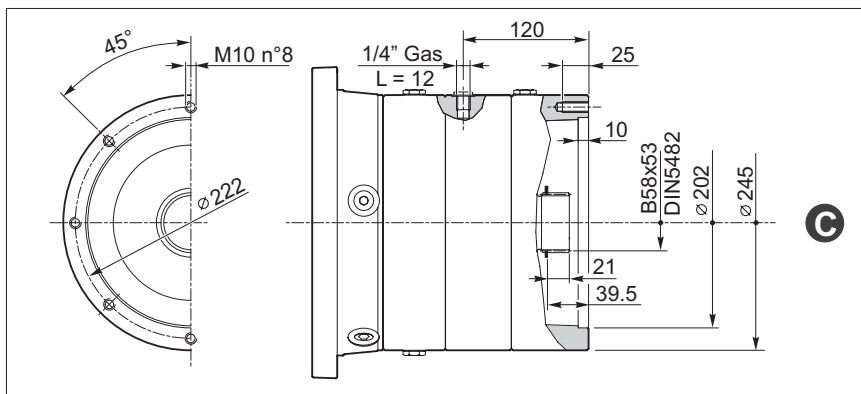

KIT CB01

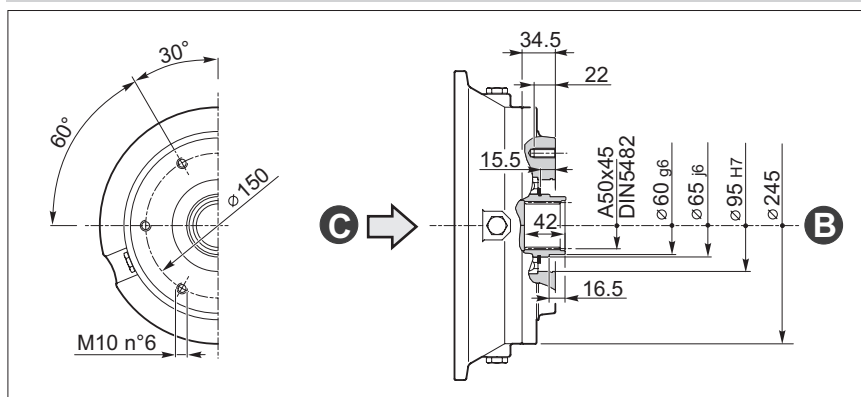

154-2357

	L2	L3	L4	A2(A)	A2(B)	A3(A)	A3(B)	A4(A)	A4(B)
RR2500									
RR3200									
RR4000									
RR5200									
RR6500									
RR8000									
RR10000									
RR15000									
RR20000									
RR25000									
RR30000									
RR40000									

Kit di trasformazione ingresso per riduttori lineari e angolari e di trasformazione per freni RF170-290; trasforma l'ingresso tipo (C) in ingresso tipo (B) consentendo il montaggio di ulteriori accoppiamenti motore.
Consultare le apposite tabelle degli accoppiamenti per verificare la compatibilità.

Input transformation kit for linear and angular reduction gears and for RF170-290 brakes; transforms a type (C) input into a type (B) input so that other motor couplings can be mounted.
Please consult the relative couplings tables to check compatibility.

Satz zur Umwandlung vom Eingang für Linear- und Winkelgetriebe und für Bremsen RF170-290. Wandelt den Eingang vom Typ (C) in einen Eingang vom Typ (B) um und erlaubt so die Montage weiterer Motorkupplungen.
Die Kompatibilität anhand der Tabellen der Kupplungen prüfen.

Kit de transformation de l'entrée pour réducteurs linéaires, angulaires et pour les freins RF170-290; transforme l'entrée type (C) en entrée type (B) pour le montage d'accouplements supplémentaires au moteur.
Voir les tableaux des accouplements pour s'assurer de la compatibilité.

Kit de transformación de entrada para reductores lineales, angulares y para los frenos RF170-290; transforma la entrada de tipo (C) en entrada de tipo (B), permitiendo el montaje de ulteriores acoplamientos motor.
Consúltense las correspondientes tablas de los acoplamientos para comprobar la compatibilidad.

Kit de transformação entrada para reductores lineares, angulares e para freios RF170-290; transforma a entrada de tipo (C) em entrada de tipo (B) consentindo a montagem de outras acoplagens de motor.
Consultar as respetivas tabelas das acoplagens para verificar a compatibilidade.

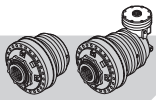

Ingresso standard / Standard input / Standardeingang
Entrée standard / Entrada standard / Entrada padrão

D

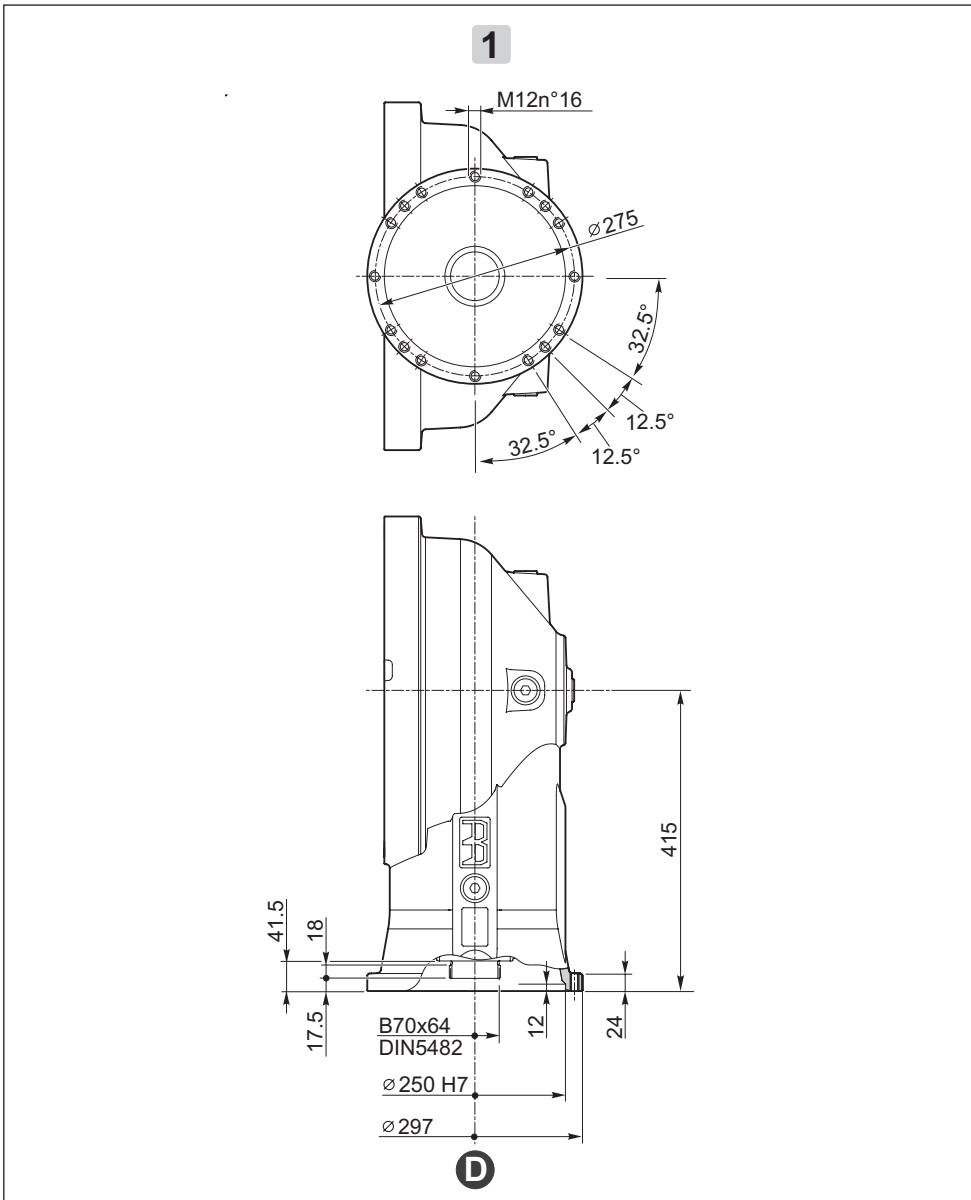
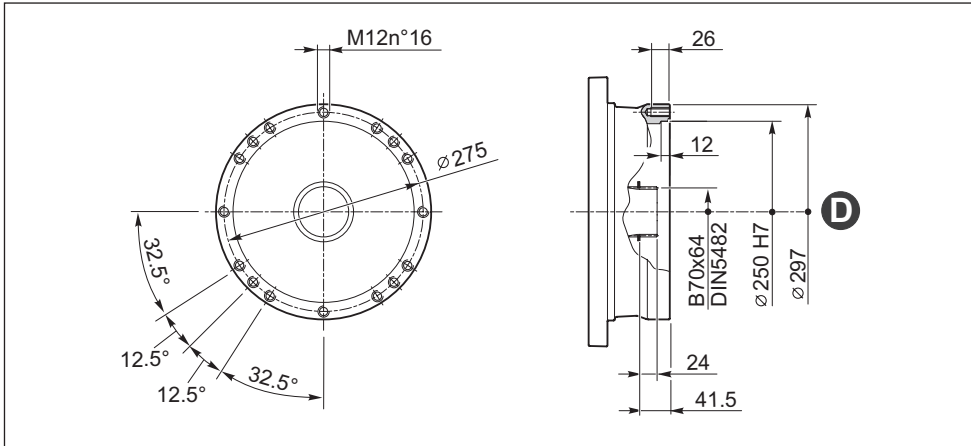

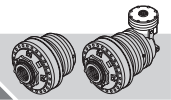

L35-2

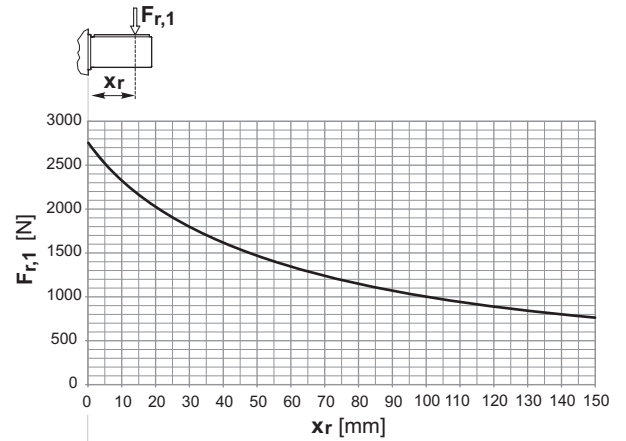
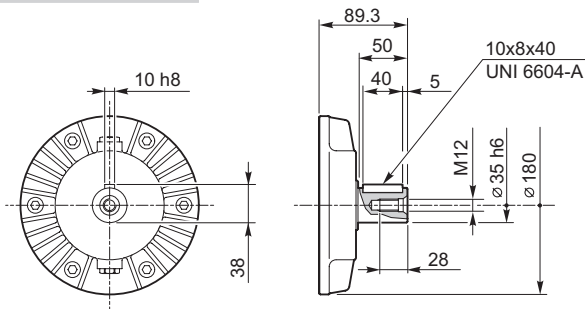

L48

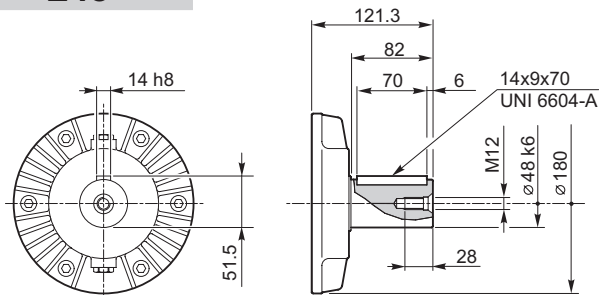

M65CF

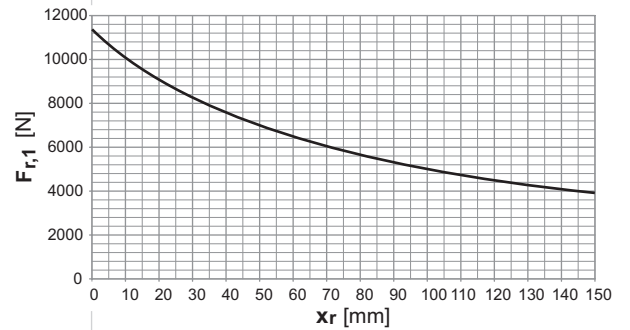
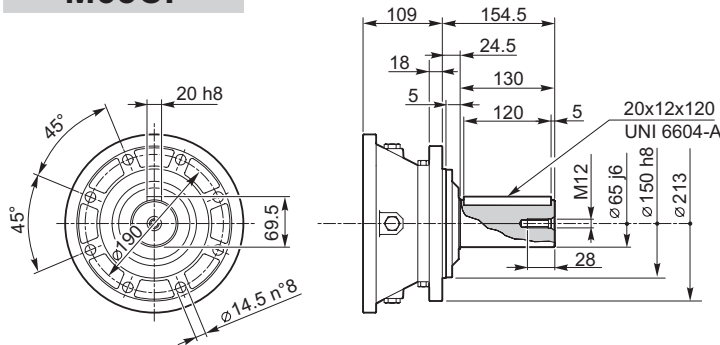

M65SF

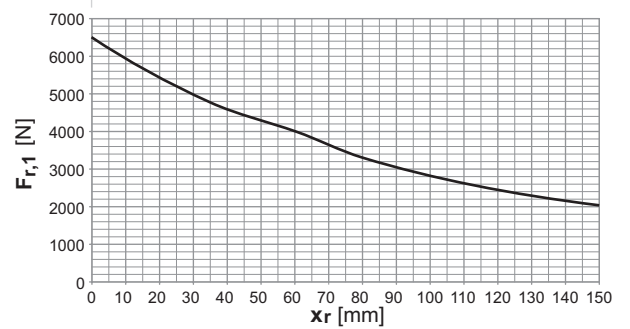
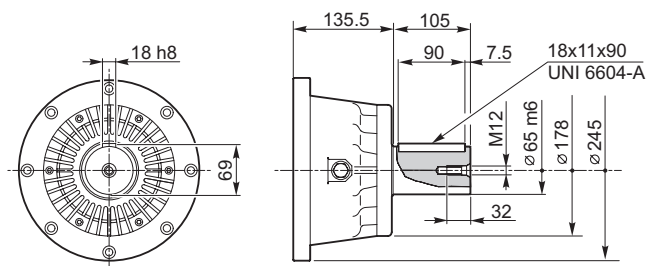

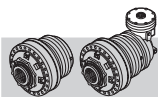

10 ENTRATE VELOCI / HIGH-SPEED INPUTS / SCHNELLE EINGÄNGE
ENTREES RAPIDES / ENTRADAS RÁPIDAS / ENTRADAS RÁPIDAS

P65CF

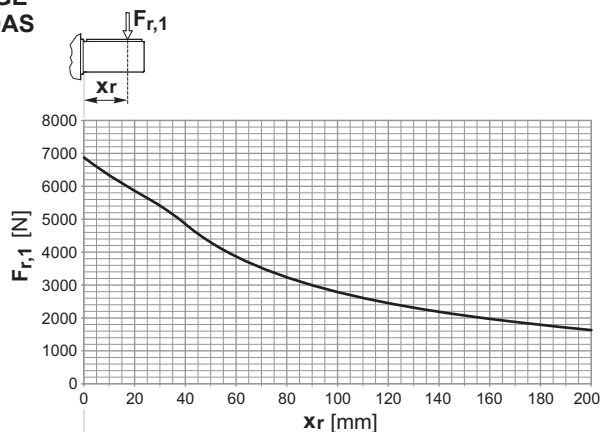
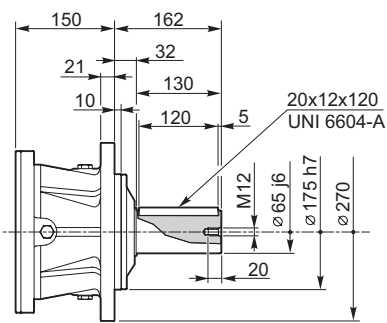
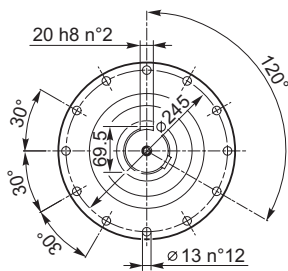

P100SF-1

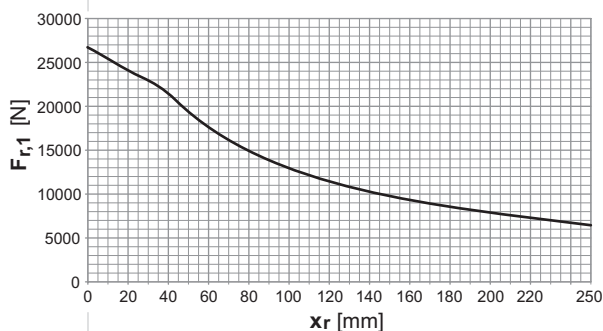
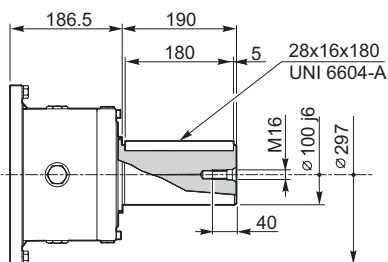
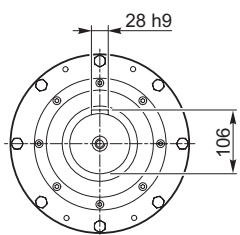

P100SF-2

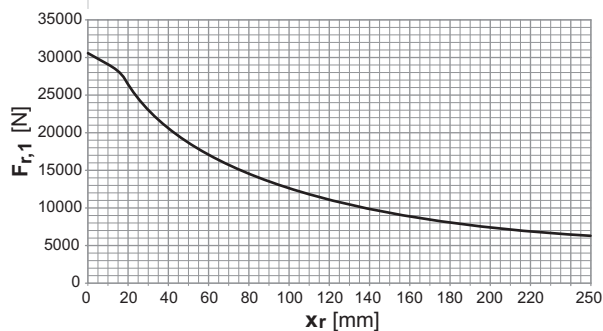
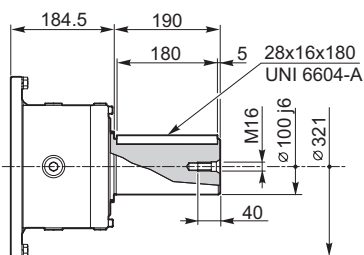
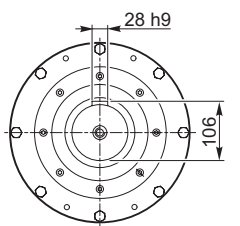

P100SF-3

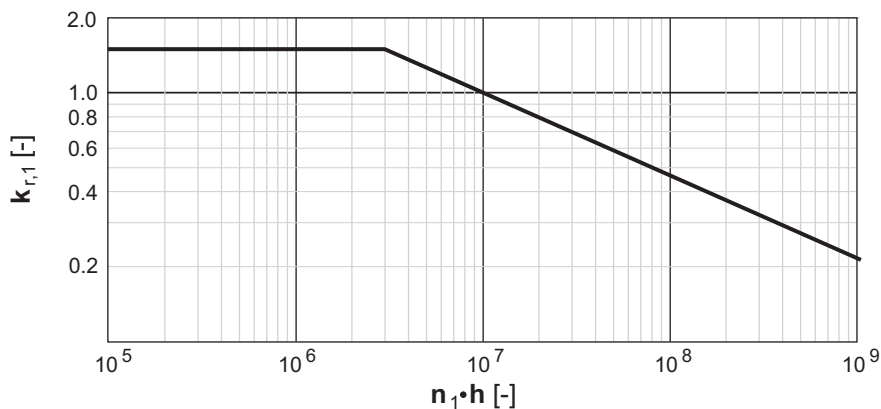
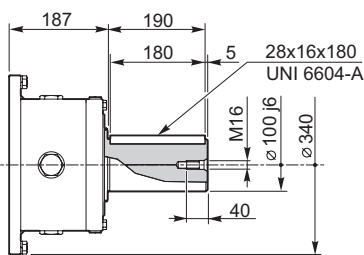
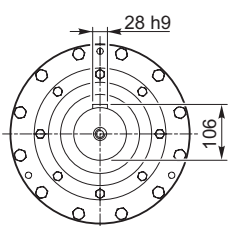



RF2/..

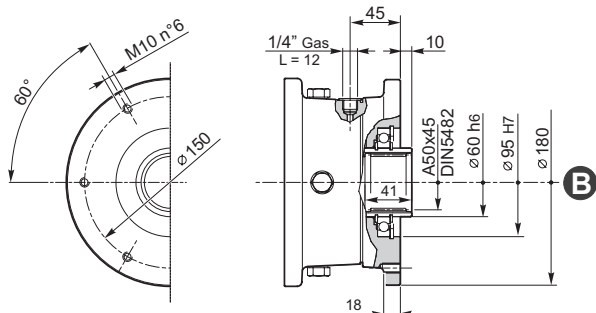

RF2/..		RF2/7	RF2/14	RF2/21	RF2/32	RF2/43	RF2/60
T_F	[Nm]	60 ÷ 80	130 ÷ 150	200 ÷ 220	310 ÷ 340	410 ÷ 450	570 ÷ 600
p_a min	[bar]	4 ÷ 5	8 ÷ 9	12 ÷ 13	18 ÷ 20	24 ÷ 26	27 ÷ 32
p_{ac}	[bar]	40					
p_a max	[bar]	250					
V_{ca}	[cm ³]	7 ÷ 8					
M	[kg]	10.5					
V_s	—	VG 150					
n_1 max	[min ⁻¹]	1500					

RF5/..- RFF5/..

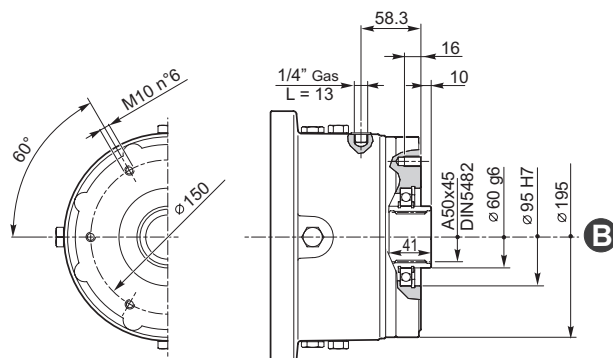

RF5/.. RFF5/..		RF5/21 RFF5/21	RF5/29 RFF5/29	RF5/43 RFF5/43	RF5/65 RFF5/65	RF5/85 RFF5/85	RF5/110 RFF5/110	RF5/130 RFF5/130
T_F	[Nm]	180 ÷ 230	280 ÷ 330	420 ÷ 460	610 ÷ 700	830 ÷ 920	1080 ÷ 1180	1260 ÷ 1360
p_a min	[bar]	4 ÷ 5	6 ÷ 7	9 ÷ 10	13 ÷ 15	18 ÷ 20	23 ÷ 25	27 ÷ 29
p_{ac}	[bar]	40						
p_a max	[bar]	250						
V_o max	[l]	0.30/0.60						
V_{ca}	[cm ³]	8 ÷ 9						
M	[kg]	21						
V_s	—	VG 32						
n_1 max	[min ⁻¹]	1000						

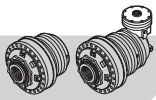

RF170 ÷ 290

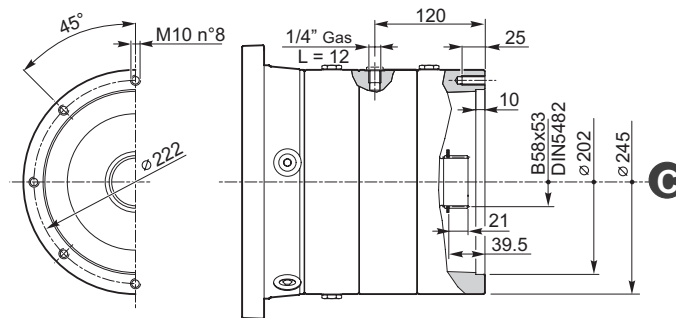

RF170 ÷ 290		RF170	RF200	RF230	RF290
T_F	[Nm]	1700	1980	2260	2830
p_a min	[bar]	25 ÷ 27	22 ÷ 24	25 ÷ 27	25 ÷ 27
p_{ac}	[bar]	40			
p_a max	[bar]	250			
V_o max	[l]	0.45/0.90			
V_{ca}	[cm ³]	27 ÷ 30			
kg	[kg]	64			
V_s	—	VG 32			
n_1 max	[min ⁻¹]	750			

I freni RF2/.. condividono la lubrificazione con il riduttore; per i freni RF5/.. RFF5/.. e RF170÷290 si consiglia l'uso di olio minerale di tipo idraulico con viscosità ISO VG 32.

In ogni caso per il comando dell'apertura del freno utilizzare olio minerale o sintetico di tipo idraulico con viscosità ISO VG 32. Non utilizzare oli vegetali.

L'huile lubrifiante pour typologie de Freins RF2/ est la même que celle qui est utilisée pour la lubrification du réducteur ; pour la lubrification des freins de typologie RF5/.. RFF5/.. et RF170-290, il est conseillé d'utiliser une huile minérale de type hydraulique avec une viscosité ISO VG 32.

Dans tous les cas, pour la commande de l'ouverture du frein, utilisez de l'huile minérale ou synthétique de type hydraulique avec viscosité ISO VG 32. Ne pas utiliser d'huiles végétales.

The RF2/.. brakes share the same lubrication with the reduction gear; we recommend using a hydraulic type mineral oil with an ISO VG 32 viscosity for the RF5/.. RFF5/.. e RF170÷290 brakes.

In all cases use either a mineral or synthetic hydraulic oil with an ISO VG 32 viscosity for the brake opening control. Do not use vegetable oils.

Los frenos RF2/.. comparten la lubricación con el reductor; para los frenos RF5/.. RFF5/.. y RF170÷290 se aconseja utilizar aceite mineral de tipo hidráulico con viscosidad ISO VG 32.

En todo caso, para el mando de la apertura del freno, utilizar aceite mineral o sintético de tipo hidráulico con viscosidad ISO VG 32. No utilizar aceites vegetales.

Die Bremsen RF2/... teilen die Schmierung mit dem Untersetzungsgetriebe: Für die Bremsen RF5/.. RFF5/.. und RF170-290 wird die Verwendung von Mineralöl vom hydraulischen Typ mit einer Viskosität von ISO VG 32 geraten.

Für die Steuerung des Öffnens der Bremse muss ein Mineralöl oder synthetisches Öl vom hydraulischen Typ mit einer Viskosität von ISO VG 32 verwendet werden. Auf keinen Fall pflanzliche Öle verwenden!

Os freios RF2/.. compartilham a lubrificação com o reductor; para freios RF5/.., RFF5/.. e RF 170÷290 aconselhamos o uso de óleo mineral de tipo hidráulico com viscosidade ISO VG 32.

Em todo o caso, para o comando da abertura do freio usar óleo mineral ou sintético de tipo hidráulico com viscosidade ISO VG 32. Nunca usar óleos vegetais.

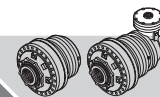

		Legenda	Legend	Zeichenerklärung
T_F	[Nm]	Coppia statica	<i>Static torque</i>	Statisches Drehmoment
p_a min	[bar]	Min. pressione di apertura	<i>Min. opening pressure</i>	Mindestöffnungsdruck
p_{ac}	[bar]	Pressione di apertura consigliata	<i>Recommended opening pressure</i>	Empfohlener Öffnungsdruck
p_a max	[bar]	Max. pressione di apertura	<i>Max. opening pressure</i>	Max. Öffnungsdruck
V_o max	[l]	Volume di olio lubrificante (Orizzontale/Verticale)	<i>Lubricating oil volume (Horizontal/Vertical)</i>	Menge Schmieröl (horizontal/vertikal)
V_s		Viscosità consigliata per l'olio di lubrificazione	<i>Recommended viscosity for the lubricant oil</i>	Empfohlene Viskosität für Schmieröl
V_{ca}	[cm ³]	Min. volume di olio comando apertura freno	<i>Min. volume of oil to control brake opening</i>	Mindestmenge Öl Steuerung Bremsenöffnung
M	[kg]	Massa	<i>Mass</i>	Gewicht
n_1 max	[min ⁻¹]	Max. giri in ingresso	<i>Max. revs in input</i>	Max. Drehzahl am Eingang

		Légende	Leyenda	Legenda
T_F	[Nm]	Couple statique	<i>Par estático</i>	Par estático
p_a min	[bar]	Pression d'ouverture minimum	<i>Presión mín. de apertura</i>	Min. pressão de abertura
p_{ac}	[bar]	Pression d'ouverture conseillée	<i>Presión de apertura aconsejada</i>	Pressão de abertura aconselhável
p_a max	[bar]	Pression d'ouverture maximum	<i>Presión máx. de apertura</i>	Max. pressão de abertura
V_o max	[l]	Volume d'huile lubrifiante (horizontal/vertical)	<i>Volumen de aceite lubricante (Horizontal/Vertical)</i>	Volume de óleo lubrificante (Horizontal/Vertical)
V_s		Viscosité conseillée pour l'huile de lubrification	<i>Viscosidad aconsejada para el aceite de lubricación</i>	Viscosidade aconselhável para o óleo de lubrificação
V_{ca}	[cm ³]	Volume minimum d'huile de commande d'ouverture du frein	<i>Volumen mín. de aceite mando apertura freno</i>	Min. volume de óleo comando abertura freio
M	[kg]	Masse	<i>Masa</i>	Massa
n_1 max	[min ⁻¹]	Max. tours en entrée	<i>Revoluciones máx. en entrada</i>	Max. Rotações em entrada

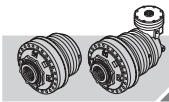

12 ACCOPPIAMENTI PER MOTORI IDRAULICI ED ELETTRICI

Nelle pagine seguenti sono riportati gli accoppiamenti disponibili per motori idraulici ed elettrici.

Per ciascun accoppiamento sono indicati il codice d'ordine e la quota **X** da sommare alla lunghezza del riduttore, in configurazione di ingresso standard, per ottenere l'ingombro totale.

È inoltre indicato il tipo di configurazione in ingresso richiesta sul riduttore (standard, predisposizione **RF** o predisposizione **BOC**) per consentire il montaggio dell'accoppiamento.

Nel caso di riduttori con predisposizione RF la lunghezza da considerare per il riduttore è sempre quella relativa al riduttore in configurazione standard.

Altri tipi di accoppiamenti sono disponibili a richiesta.

Esempio 1

Si vuole selezionare un accoppiamento per un motore idraulico con flangiatura SAE A 2 fori ed albero cilindrico da 25 mm su un riduttore RR5200 L4.

Consultando la tabella degli accoppiamenti per motori idraulici si vede che l'accoppiamento richiesto è disponibile e può essere montato sul riduttore con ingresso in configurazione standard; il codice dell'accoppiamento è 154-2300M317, mentre la quota da sommare alla lunghezza del riduttore, che in questo caso è 492.5 mm, è X=25 mm.

L'ingombro totale sarà dunque pari a 492.5+25=517.5 mm.

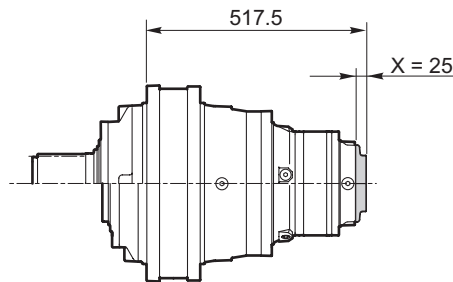

12 HYDRAULIC AND ELECTRIC MOTORS COUPLINGS

The couplings available for hydraulic and electric motors are given on the following pages.

The order code and value **X** are given for each coupling; this value has to be added to the length of the reduction gear (in the standard input configuration) to find the total dimension.

The type of input configuration required for the reduction gear is also indicated (standard, **RF** setup or **BOC** setup) so the coupling can be mounted.

For those reduction gears with RF setup, the length to consider for the reduction gear is always the length of the standard configuration reduction gear.

Other coupling types are available on request.

Example 1

You want to select a coupling for a hydraulic motor with a 2-hole SAE flanging and a 25 mm cylindrical shaft on an RR5200 L4 reduction gear.

If you look at the couplings table for hydraulic motors you will see that the coupling required is available and can be mounted on the reduction gear with a standard configuration input; the coupling code is 154-2300M317 while the value to add to the length of the reduction gear, which is 492.5 mm in this case, is X=25 mm. So we have a total dimension of 492.5+25=517.5 mm.

12 KUPPLUNGEN FÜR HYDRAULIK- MOTOREN UND ELEKTROMOTOREN

Auf den folgenden Seiten sind die für Hydraulikmotoren und Elektromotoren erhältlichen Kupplungen aufgelistet.

Für jede Kupplung sind die Bestellnummer und der Wert **X** angegeben, der zur Länge vom Planetengetriebe bei Konfiguration mit Standardeingang addiert werden muss, um den Gesamttraumbedarf zu ermitteln.

Außerdem ist die am Planetengetriebe erforderliche Eingangskonfiguration angegeben (Standard, ausgelegt auf RF oder ausgelegt auf **BOC**), um die Montage der Kupplung zu ermöglichen.

Bei Planetengetriebe, die auf **RF** ausgelegt sind, entspricht die Länge, die für das Planetengetriebe berücksichtigt werden muss, immer der des Planetengetriebes in der Standardkonfiguration.

Auf Wunsch sind auch andere Kupplungen erhältlich.

Beispiel 1

Es soll eine Kupplung für einen Hydraulikmotor mit Flansch SAE mit zwei Bohrungen und 25 mm Zylinderwelle auf einem Planetengetriebe RR5200 L4 ausgewählt werden.

Der Tabelle mit den Kupplungen für Hydraulikmotoren kann entnommen werden, dass die erforderliche Kupplung verfügbar ist und auf dem Planetengetriebe mit Eingang mit Standardkonfiguration montiert werden kann. Die Bestellnummer der Kupplung ist 154-2300M317, der Wert, der zur Länge vom Planetengetriebe (in diesem Fall 492.5 mm) addiert werden muss, beträgt X=25 mm. Für den Gesamttraumbedarf ergibt sich damit ein Wert von 492.5+25=517.5 mm.

	Code	SAE A 2B 16/32 x 13				SAE A 2/MB 16/32 x 13				SAE A 2/MB 16/32 x 19				SAE A 2B ø25			
		154-2300M267	154-2300M674	154-2300M653	154-2300M675	154-2300M654	154-2300M673	154-2300M652	154-2300M315	154-2300M671	154-2300M660	154-2300M673	154-2300M652	154-2300M315	154-2300M671	154-2300M660	
	X	24	23	44	23	44	23	44	23	44	24	23	44	23	44		
RR2500	L2	•	•	•	•	•	•	•	•	•	•	•	•	•	•		
	L3	•	•	•	•	•	•	•	•	•	•	•	•	•	•		
	L4	•	•	•	•	•	•	•	•	•	•	•	•	•	•		
	A2	•	•	•	•	•	•	•	•	•	•	•	•	•	•		
RR3200	L2	•	•	•	•	•	•	•	•	•	•	•	•	•	•		
	L3	•	•	•	•	•	•	•	•	•	•	•	•	•	•		
	L4	•	•	•	•	•	•	•	•	•	•	•	•	•	•		
	A2	•	•	•	•	•	•	•	•	•	•	•	•	•	•		
RR4000	L2	•	•	•	•	•	•	•	•	•	•	•	•	•	•		
	L3	•	•	•	•	•	•	•	•	•	•	•	•	•	•		
	L4	•	•	•	•	•	•	•	•	•	•	•	•	•	•		
	A2	•	•	•	•	•	•	•	•	•	•	•	•	•	•		
RR5200	L2	•	•	•	•	•	•	•	•	•	•	•	•	•	•		
	L3	•	•	•	•	•	•	•	•	•	•	•	•	•	•		
	L4	•	•	•	•	•	•	•	•	•	•	•	•	•	•		
	A2	•	•	•	•	•	•	•	•	•	•	•	•	•	•		



12 ACCOUPLEMENTS POUR MOTEURS HYDRAULIQUES ET ELECTRIQUES

Les accouplements existants pour les moteurs hydrauliques et électriques sont indiqués sur les pages suivantes.

A chaque accouplement correspond l'indication du code à utiliser au moment de la commande et la cote **X** à additionner à la longueur du réducteur, en configuration d'entrée standard, pour obtenir l'encombrement total.

Le type de configuration en entrée demandée sur le réducteur (standard, pré-réglage **RF** ou pré-réglage **BOC**) est aussi indiqué pour permettre le montage de l'accouplement.

Pour des réducteurs avec pré-réglage RF, la longueur à prendre en considération pour le réducteur est toujours la longueur relative au réducteur en configuration standard.

Il est possible d'obtenir d'autres types d'accouplement sur simple demande.

Exemple 1

Pour trouver un accouplement pour un moteur hydraulique avec bridage SAE à 2 trous et arbre cylindrique de 25 mm sur un réducteur RR5200 L4, en consultant le tableau des accouplements pour moteurs hydraulique, on voit que l'accouplement demandé existe et peut être monté sur le réducteur avec entrée en configuration standard; le code de l'accouplement est 154-2300M317, alors que la cote à additionner à la longueur du réducteur, qui dans ce cas est de 492.5 mm, est X=25 mm. L'encombrement total sera donc de 492.5+25=517.5 mm.

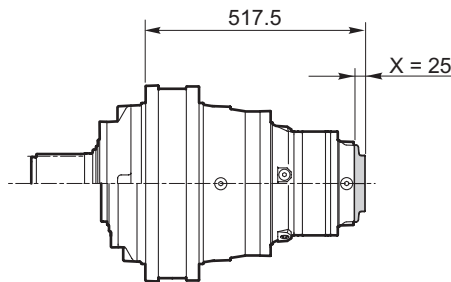

12 ACOPLAMIENTOS PARA MOTORES HIDRÁULICOS Y ELÉCTRICOS

En las páginas siguientes se presentan los acoplamientos disponibles para motores hidráulicos y eléctricos.

Para cada acoplamiento se indican el código de pedido y la cota **X** a sumar a la longitud del reductor, en configuración de entrada estándar, para obtener las medidas máximas totales.

Además se indica el tipo de configuración en entrada pedida en el reductor (estándar, predisposición **RF** o predisposición **BOC**) para consentir el montaje del acoplamiento.

En el caso de reductores con predisposición RF, la longitud a considerar para el reductor es siempre aquella relativa al reductor en configuración estándar.

Otros tipos de acoplamiento están disponibles a petición.

Ejemplo 1

Se desea seleccionar un acoplamiento para un motor hidráulico con brida SAE de 2 agujeros y eje cilíndrico de 25 mm en un reductor RR5200 L4.

Consultando la tabla de los acoplamientos para motores hidráulicos podemos ver que el acoplamiento requerido está disponible y se puede montar en el reductor con entrada en configuración estándar; el código del acoplamiento es el 154-2300M317, mientras que la cota a sumar a la longitud del reductor, que en este caso es 492.5 mm, es X=25 mm. Las medidas máximas totales serán por lo tanto 492.5+25=517.5 mm.

12 ACOPLAGENS PARA MOTORES HIDRÁULICOS E ELÉTRICOS

Nas páginas seguintes estão indicadas as acoplagens disponíveis para motores hidráulicos e elétricos.

Para cada acoplamento estão indicados o código de encomenda e a cota **X** a somar ao comprimento do reductor, em configuração de entrada padrão, para obter a dimensão total.

Também está indicado o tipo de configuração em entrada necessária no reductor (padrão, predisposição **RF** ou predisposição **BOC**) para consentir a montagem da acoplagem.

No caso de reductores com predisposição RF o comprimento a considerar para o reductor é sempre aquele relativa ao reductor em configuração padrão.

Outros tipos de acoplamentos podem ser fornecidos a pedido.

Exemplo 1

Deseja-se selecionar uma acoplagem para um motor hidráulico com flange SAE de 2 furos e veio cilíndrico de 25 mm sobre um reductor RR5200 L4.

Consultando a tabela das acoplagens para motores hidráulicos pode-se ver que a acoplagem necessária é disponível e pode ser montada sobre o reductor com entrada em configuração padrão; o código da acoplagem é 154-2300M317, enquanto que a cota a somar ao comprimento do reductor, que neste caso é 492.5 mm, é X=25 mm. Portanto, a dimensão total será igual a 492.5+25=517.5 mm.

Code	SAE A 2B				SAE A 2B Ø25	SAE				
	16/Ø2 x13	16/Ø2 x13	16/Ø2 x13	16/Ø2 x15		Ø7/8"	Ø1"	Ø1"	Ø1"	
154-2300M637	24	23	44	23	44	23	44	24	23	44
154-2300M674										
154-2300M653										
154-2300M675										
154-2300M654										
154-2300M317					25					
154-2300M673										
154-2300M652										
154-2300M615										
154-2300M671										
154-2300M650										
RR2500										
RR3200										
RR4000										
RR5200										

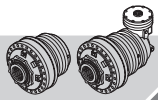

Esempio 2

Si vuole selezionare un accoppiamento per un motore idraulico con flangiatura SAE A 4 fori ed albero cilindrico da 1 pollice su un riduttore RR5200 L4.

Consultando la tabella degli accoppiamenti per motori idraulici si vede che l'accoppiamento richiesto è disponibile e può essere montato sul riduttore con ingresso predisposto RF; il codice dell'accoppiamento è 154-2300M560, mentre la quota da sommare alla lunghezza del riduttore, che in questo caso è 492.5 mm, è X=44 mm. L'ingombro totale sarà dunque pari a 492.5+44=536.5 mm.

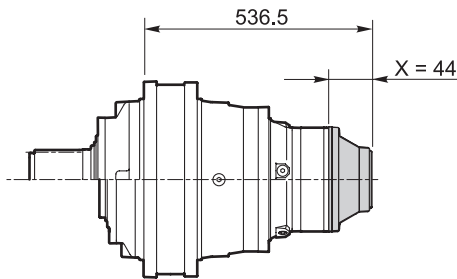

Example 2

You want to select a coupling for a hydraulic motor with a 4-hole SAE flanging and a 1 inch cylindrical shaft on an RR5200 L4 reduction gear.

If you look at the couplings table for hydraulic motors you will see that the coupling required is available and can be mounted on the reduction gear with an RF setup input; the coupling code is 154-2300M560 while the value to add to the length of the reduction gear, which is 492.5 mm in this case, is X=44 mm. So we have a total dimension of 492.5+44=536.5 mm.

Beispiel 2

Es soll eine Kupplung für einen Hydraulikmotor mit Flansch SAE mit 4 Bohrungen und 1 Zoll Zylinderwelle auf einem Planetengetriebe RR5200 L4 ausgewählt werden. Der Tabelle mit den Kupplungen für Hydraulikmotoren kann entnommen werden, dass die erforderliche Kupplung verfügbar ist und auf dem Planetengetriebe mit einem auf RF ausgelegten Eingang montiert werden kann. Die Bestellnummer der Kupplung ist 154-2300M560, der Wert, der zur Länge v.m Planetengetriebe (in diesem Fall 492.5 mm) addiert werden muss, beträgt X=44 mm. Für den Gesamttraumbedarf ergibt sich damit ein Wert von 492.5+44=536.5 mm.

Code	SAE									
	SAE A 2B 16oz 213	SAE A 2AB 16oz 213	SAE A 2AB 16oz 213	SAE A 2AB 16oz 213	SAE A 2B 242	SAE A 2AB 242	SAE A 2B 242	SAE A 2B 242	SAE A 2B 242	SAE A 2B 242
X	24	23	44	23	44	24	23	44	24	23
RR2500	*	*	*	*	*	*	*	*	*	*
RR3200	*	*	*	*	*	*	*	*	*	*
RR4000	*	*	*	*	*	*	*	*	*	*
RR5200	*	*	*	*	*	*	*	*	*	*

Esempio 3

Si vuole selezionare un accoppiamento per un motore elettrico IEC grandezza 80 su un riduttore RR5200 A3(A).

Consultando la tabella degli accoppiamenti per motori elettrici si vede che l'accoppiamento richiesto è disponibile e può essere montato sul riduttore con ingresso in configurazione standard; il codice dell'accoppiamento è 154-2300M229, mentre la quota da sommare all'altezza del riduttore, che in questo caso è 247.5 mm, è X=24 mm. L'ingombro totale sarà dunque pari a 247.5+24=271.5 mm.

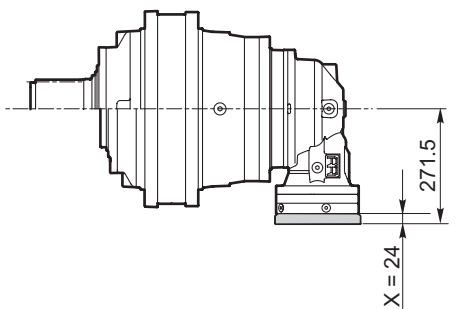

Example 3

You want to select a coupling for a size 80 IEC electric motor on an RR5200 A3(A) reduction gear.

If you look at the couplings table for electric motors you will see that the coupling required is available and can be mounted on the reduction gear with a standard configuration input; the coupling code is 154-2300M229 while the value to add to the height of the reduction gear, which is 247.5 mm in this case, is X=24 mm. So we have a total dimension of 247.5+24=271.5 mm.

Beispiel 3

Es soll eine Kupplung für einen Elektromotor IEC mit einer Größe von 80 auf einem Planetengetriebe RR5200 A3(A) ausgewählt werden.

Der Tabelle mit den Kupplungen für Elektromotoren kann entnommen werden, dass die erforderliche Kupplung verfügbar ist und auf dem Planetengetriebe mit Eingang mit Standardkonfiguration montiert werden kann. Die Bestellnummer der Kupplung ist 154-2300M229, der Wert, der zur Höhe vom Planetengetriebe (in diesem Fall 247.5 mm) addiert werden muss, beträgt X=24 mm. Für den Gesamttraumbedarf ergibt sich damit ein Wert von 247.5+24=271.5 mm.

Code	IEC B5									
	63	71	80	90	100-112	132	160	180	200	225
X	24	18.5	18.1	25.2	24	32.5	30	32.5	32	32
RR2500	*	*	*	*	*	*	*	*	*	*
RR3200	*	*	*	*	*	*	*	*	*	*
RR4000	*	*	*	*	*	*	*	*	*	*
RR5200	*	*	*	*	*	*	*	*	*	*

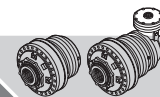

Exemple 2

Pour choisir un accouplement pour un moteur hydraulique avec bridage SAE à 4 trous et arbre cylindrique d'1 pouce sur un réducteur RR5200 L4, consulter le tableau des accouplements pour moteurs hydrauliques, on voit que l'accouplement demandé existe et peut être monté sur le réducteur avec entrée préréglé RF; le code de l'accouplement est 154-2300M560, alors que la cote à additionner à la longueur du réducteur, qui dans ce cas est de 492.5 mm, est X=44 mm. L'encombrement total sera donc de 492.5+44=536.5 mm.

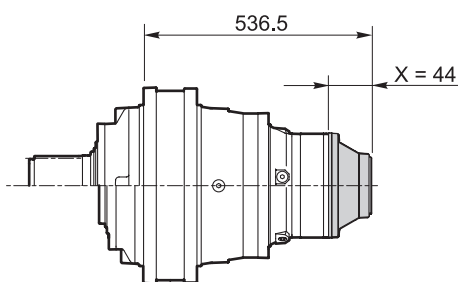

Ejemplo 2

Se desea seleccionar un acoplamiento para un motor hidráulico con brida SAE de 4 agujeros y eje cilíndrico de 1 pulgada en un reductor RR5200 L4. Consultando la tabla de los acoplamientos para motores hidráulicos podemos ver que el acoplamiento requerido está disponible y se puede montar en el reductor con entrada predispuesta RF; el código del acoplamiento es el 154-2300M560, mientras que la cota a sumar a la longitud del reductor, que en este caso es 492.5 mm, es X=44 mm. Las medidas máximas totales serán por lo tanto 492.5+44=536.5 mm

Exemplo 2

Deseja-se selecionar uma acoplagem para um motor hidráulico com flange SAE de 4 furos e veio cilíndrico de 1 polegada sobre um redutor RR5200 L4. Consultando a tabela das acoplagens para motores hidráulicos pode-se ver que a acoplagem necessária é disponível e pode ser montada no redutor com entrada predisposta RF; o código da acoplagem é 154-2300M560, enquanto que a cota a somar ao comprimento do redutor, que neste caso é 492.5 mm, é X=44 mm. Portanto, a dimensão total será igual a 492.5+44=536.5 mm.

Code	SAE											
	SAE A 2B 1/2" 213	SAE A 2/4B 1/2" 213	SAE A 3/4B 1/2" 213	SAE A 1/2B 213	SAE A 3/4B 213	SAE A 2B 213	SAE A 3/4B 213	SAE A 2B 213	SAE A 3/4B 213	SAE A 2B 213	SAE A 3/4B 213	SAE A 2B 213
RR2500	*	*	*	*	*	*	*	*	*	*	*	*
RR3200	*	*	*	*	*	*	*	*	*	*	*	*
RR4000	*	*	*	*	*	*	*	*	*	*	*	*
RR5200	*	*	*	*	*	*	*	*	*	*	*	*

Exemple 3

Pour choisir un accouplement pour un moteur électrique IEC grandeur 80 sur un réducteur RR5200 A3(A), consulter le tableau des accouplements pour moteurs électriques, on voit que l'accouplement demandé existe et peut être monté sur le réducteur avec entrée en configuration standard; le code de l'accouplement est 154-2300M229, alors que la cote à additionner à la hauteur du réducteur, qui dans ce cas est de 247.5 mm, est X=24 mm. L'encombrement total sera donc de 247.5+24=271.5 mm.

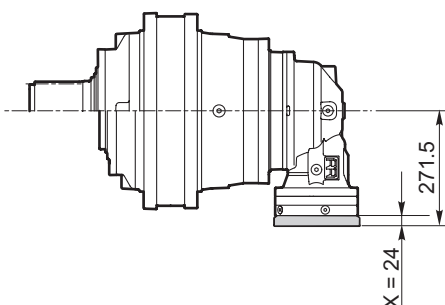

Ejemplo 3

Se desea seleccionar un acoplamiento para un motor eléctrico IEC talla 80 en un reductor RR5200 A3(A). Consultando la tabla de los acoplamientos para motores eléctricos podemos ver que el acoplamiento requerido está disponible y se puede montar en el reductor con entrada en configuración estándar; el código del acoplamiento es el 154-2300M229, mientras que la cota a sumar a la altura del reductor, que en este caso es 247,5 mm, es X=24 mm. Las medidas máximas totales serán por lo tanto 247.5+24=271.5 mm.

Exemplo 3

Deseja-se selecionar uma acoplagem para um motor elétrico IEC grandeza 80 sobre um redutor RR5200 A3(A). Consultando a tabela das acoplagens para motores elétricos pode-se ver que a acoplagem necessária é disponível e pode ser montada no redutor com entrada em configuração padrão; o código da acoplagem é 154-2300M229, enquanto que a cota a somar à altura do redutor, que neste caso é 247.5 mm, é X=24 mm. Portanto, a dimensão total será igual a 247.5+24=271.5 mm

Code	IEC B5											
	63	71	90	100-112	132	160	180	200	250	315	355	400
RR2500	*	*	*	*	*	*	*	*	*	*	*	*
RR3200	*	*	*	*	*	*	*	*	*	*	*	*
RR4000	*	*	*	*	*	*	*	*	*	*	*	*
RR5200	*	*	*	*	*	*	*	*	*	*	*	*

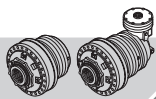

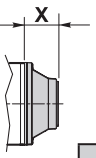
	SAE															
	SAE A 2B 16/32 z13	SAE A 2/4B 16/32 z13	SAE A 2/4B 16/32 z15	SAE A 2B ø25	SAE A 2/4B ø7/8"	SAE A 2B ø1"	SAE A 2/4B ø1"	SAE A 2B ø1 1/4"	SAE A 2B 1" 6B	SAE A 2/4B 1" 6B						
	Code	154-2300M267	154-2300M574	154-2300M563	154-2300M575	154-2300M564	154-2300M317	154-2300M573	154-2300M562	154-2300M315	154-2300M571	154-2300M560	154-2300M269	154-2300M272	154B2702	154B2700
X	24	23	44	23	44	25	23	44	25	23	44	24	24	23	44	
RR2500	L2	• 1)					• 1)			• 1)			• 1)	• 1)		
	L3	•		■		■	•			•		■	•	•		■
	L4	•	■		■		•	■		•	■		•	•	■	■
	A2 (A)	• 1)					• 1)			• 1)			• 1)	• 1)		
	A2 (B)	• 1)					• 1)			• 1)			• 1)	• 1)		
RR3200	L2	• 1)					• 1)			• 1)			• 1)	• 1)		
	L3	•		■		■	•			•		■	•	•		■
	L4	•	■		■		•	■		•	■		•	•	■	■
	A2 (A)	• 1)					• 1)			• 1)			• 1)	• 1)		
	A2 (B)	• 1)					• 1)			• 1)			• 1)	• 1)		
RR4000	L2	• 1)					• 1)			• 1)			• 1)	• 1)		
	L3	•		■		■	•			•		■	•	•		■
	L4	•	■		■		•	■		•	■		•	•	■	■
	A2 (A)	• 1)					• 1)			• 1)			• 1)	• 1)		
	A2 (B)	• 1)					• 1)			• 1)			• 1)	• 1)		
RR5200	L2	• 1)					• 1)			• 1)			• 1)	• 1)		
	L3	•		■		■	•			•		■	•	•		■
	L4	•	■		■		•	■		•	■		•	•	■	■
	A2 (A)	• 1)					• 1)			• 1)			• 1)	• 1)		
	A2 (B)	• 1)					• 1)			• 1)			• 1)	• 1)		
RR6500	L2	• 1)					• 1)			• 1)			• 1)	• 1)		
	L3	• 1)		■		■	• 1)			• 1)		■	• 1)	• 1)		■
	L4	•		■		■	•			•		■	•	•		■
	A3 (A)	• 1)					• 1)			• 1)			• 1)	• 1)		
	A3 (B)	• 1)					• 1)			• 1)			• 1)	• 1)		
RR8000	L2	• 1)					• 1)			• 1)			• 1)	• 1)		
	L3	• 1)		■		■	• 1)			• 1)		■	• 1)	• 1)		■
	L4	•		■		■	•			•		■	•	•		■
	A3 (A)	• 1)					• 1)			• 1)			• 1)	• 1)		
	A3 (B)	• 1)					• 1)			• 1)			• 1)	• 1)		
RR10000	L2	• 1)					• 1)			• 1)			• 1)	• 1)		
	L3	• 1)		■		■	• 1)			• 1)		■	• 1)	• 1)		■
	L4	•		■		■	•			•		■	•	•		■
	A3 (A)	• 1)					• 1)			• 1)			• 1)	• 1)		
	A3 (B)	• 1)					• 1)			• 1)			• 1)	• 1)		
RR15000	L2	• 1)					• 1)			• 1)			• 1)	• 1)		
	L3	• 1)		■		■	• 1)			• 1)		■	• 1)	• 1)		■
	L4	•		■		■	•			•		■	•	•		■
	A3 (A)	• 1)					• 1)			• 1)			• 1)	• 1)		
	A3 (B)	• 1)					• 1)			• 1)			• 1)	• 1)		
RR20000	L4	• 1)					• 1)			• 1)			• 1)	• 1)		
	A4 (A)	• 1)					• 1)			• 1)			• 1)	• 1)		
	A4 (B)	• 1)					• 1)			• 1)			• 1)	• 1)		
RR25000	L4	• 1)					• 1)			• 1)			• 1)	• 1)		
	A4 (A)	• 1)					• 1)			• 1)			• 1)	• 1)		
RR30000	L4	• 1)					• 1)			• 1)			• 1)	• 1)		
	A4 (A)	• 1)					• 1)			• 1)			• 1)	• 1)		
RR40000	L4	• 1)					• 1)			• 1)			• 1)	• 1)		
	A4 (A)	• 1)					• 1)			• 1)			• 1)	• 1)		
RF2/...	•					•			•			•	•			
RF5/...-RFF5/...	•					•			•			•	•			
RF170÷290	• 1)					• 1)			• 1)			• 1)	• 1)			

• Ingresso standard / Standard input / Standardeingang / Entrée standard / Entrada standard / Entrada padrão (—)
 ■ Predisposizione RF / RF Setup / Auslegung RF / Préréglage RF / Predisposición RF / Predisposição RF
 ○ Predisposizione BOC / BOC Setup / Auslegung BOC / Préréglage BOC / Predisposición BOC / Predisposição BOC
 1) Con / With / Mit / Avec / Con / Com **KIT CB01**

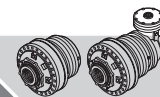

	SAE															
	SAE B 2B 16/32 z13	SAE B 2/4B 16/32 z13	SAE B 2B 16/32 z15	SAE B 2/4B 16/32 z15	SAE B 2B ø7/8"	SAE B 2/4B ø7/8"	SAE B 2B ø1"	SAE B 2/4B ø1"	SAE B 2B ø1 1/4"	SAE B 2/4B 1" 6B						
	Code	154-2300M284	154-2300M579	154-2300M568	154-2300M283	154-2300M580	154-2300M569	154-2300M290	154-2300M578	154-2300M567	154-2300M285	154-2300M576	154-2300M565	154-2300M286	154B2703	154B2701
X	24	23	44	24	23	44	24	23	44	24	23	44	24	23	44	
RR2500	L2	• 1)			• 1)			• 1)			• 1)			• 1)		
	L3	•		■	•		■	•		■	•		■	•		■
	L4	•	■	■	•	■	■	•	■	■	•	■	■	•	■	■
	A2 (A)	• 1)			• 1)			• 1)			• 1)			• 1)		
	A2 (B)	• 1)			• 1)			• 1)			• 1)			• 1)		
RR3200	L2	• 1)			• 1)			• 1)			• 1)			• 1)		
	L3	•		■	•		■	•		■	•		■	•		■
	L4	•	■	■	•	■	■	•	■	■	•	■	■	•	■	■
	A2 (A)	• 1)			• 1)			• 1)			• 1)			• 1)		
	A2 (B)	• 1)			• 1)			• 1)			• 1)			• 1)		
RR4000	L2	• 1)			• 1)			• 1)			• 1)			• 1)		
	L3	•		■	•		■	•		■	•		■	•		■
	L4	•	■	■	•	■	■	•	■	■	•	■	■	•	■	■
	A2 (A)	• 1)			• 1)			• 1)			• 1)			• 1)		
	A2 (B)	• 1)			• 1)			• 1)			• 1)			• 1)		
RR5200	L2	• 1)			• 1)			• 1)			• 1)			• 1)		
	L3	•		■	•		■	•		■	•		■	•		■
	L4	•	■	■	•	■	■	•	■	■	•	■	■	•	■	■
	A2 (A)	• 1)			• 1)			• 1)			• 1)			• 1)		
	A2 (B)	• 1)			• 1)			• 1)			• 1)			• 1)		
RR6500	L2	• 1)			• 1)			• 1)			• 1)			• 1)		
	L3	•		■	•		■	•		■	•		■	•		■
	L4	•	■	■	•	■	■	•	■	■	•	■	■	•	■	■
	A3 (A)	• 1)			• 1)			• 1)			• 1)			• 1)		
	A3 (B)	• 1)			• 1)			• 1)			• 1)			• 1)		
RR8000	L2	• 1)			• 1)			• 1)			• 1)			• 1)		
	L3	•		■	•		■	•		■	•		■	•		■
	L4	•	■	■	•	■	■	•	■	■	•	■	■	•	■	■
	A3 (A)	• 1)			• 1)			• 1)			• 1)			• 1)		
	A3 (B)	• 1)			• 1)			• 1)			• 1)			• 1)		
RR10000	L2	• 1)			• 1)			• 1)			• 1)			• 1)		
	L3	•		■	•		■	•		■	•		■	•		■
	L4	•	■	■	•	■	■	•	■	■	•	■	■	•	■	■
	A3 (A)	• 1)			• 1)			• 1)			• 1)			• 1)		
	A3 (B)	• 1)			• 1)			• 1)			• 1)			• 1)		
RR15000	L2	• 1)			• 1)			• 1)			• 1)			• 1)		
	L3	•		■	•		■	•		■	•		■	•		■
	L4	•	■	■	•	■	■	•	■	■	•	■	■	•	■	■
	A3 (A)	• 1)			• 1)			• 1)			• 1)			• 1)		
	A3 (B)	• 1)			• 1)			• 1)			• 1)			• 1)		
RR20000	L2	• 1)			• 1)			• 1)			• 1)			• 1)		
	L3	•		■	•		■	•		■	•		■	•		■
	L4	•	■	■	•	■	■	•	■	■	•	■	■	•	■	■
	A4 (A)	• 1)			• 1)			• 1)			• 1)			• 1)		
	A4 (B)	• 1)			• 1)			• 1)			• 1)			• 1)		
RR25000	L2	• 1)			• 1)			• 1)			• 1)			• 1)		
	L3	•		■	•		■	•		■	•		■	•		■
	L4	•	■	■	•	■	■	•	■	■	•	■	■	•	■	■
	A4 (A)	• 1)			• 1)			• 1)			• 1)			• 1)		
	A4 (B)	• 1)			• 1)			• 1)			• 1)			• 1)		
RR30000	L2	• 1)			• 1)			• 1)			• 1)			• 1)		
	L3	•		■	•		■	•		■	•		■	•		■
	L4	•	■	■	•	■	■	•	■	■	•	■	■	•	■	■
	A4 (A)	• 1)			• 1)			• 1)			• 1)			• 1)		
	A4 (B)	• 1)			• 1)			• 1)			• 1)			• 1)		
RR40000	L2	• 1)			• 1)			• 1)			• 1)			• 1)		
	L3	•		■	•		■	•		■	•		■	•		■
	L4	•	■	■	•	■	■	•	■	■	•	■	■	•	■	■
	A4 (A)	• 1)			• 1)			• 1)			• 1)			• 1)		
	A4 (B)	• 1)			• 1)			• 1)			• 1)			• 1)		
RF2/...	•			•			•			•			•			
RF5/...-RFF5/...	•			•			•			•			•			
RF170÷290	• 1)			• 1)			• 1)			• 1)			• 1)			

• Ingresso standard / Standard input / Standardeingang / Entrée standard / Entrada standard / Entrada padrão (—)
 ■ Predisposizione RF / RF Setup / Auslegung RF / Préréglage RF / Predisposición RF / Predisposição RF
 ○ Predisposizione BOC / BOC Setup / Auslegung BOC / Préréglage BOC / Predisposición BOC / Predisposição BOC
 1) Con / With / Mit / Avec / Con / Com **KIT CB01**

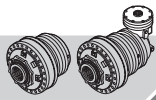

	Code	SAE													
		SAE C 2/4B 12/24 z14	SAE C 2/4B 12/24 z17	SAE C 2/4B 16/32 z21	SAE C 2/4B 16/32 z23	SAE C 4B 16/32 z23	SAE C 2/4B ø1 1/4"	SAE D 4B 16/32 z27	SAE D 4B 8/16 z13	SAE E 4B 8/16 z13	SAE E 4B 8/16 z15				
	X	31.5	46	46.5	31.5	31.5	31.5	46.5	31.5	124	70	108	70	74	112
RR2500	L2			•	•1)	•1)	•1)	•	•1)		•		•		•1)
	L3	•	■		•	•	•		•					○	•
	L4	•			•	•	•		•						•
	A2 (A)			•	•1)	•1)	•1)	•	•1)		•		•		•1)
	A2 (B)			•	•1)	•1)	•1)	•	•1)		•		•		•1)
RR3200	L2			•	•1)	•1)	•1)	•	•1)		•		•		•1)
	L3		■		•	•	•		•					○	•
	L4		■		•	•	•		•					○	•
	A2 (A)			•	•1)	•1)	•1)	•	•1)		•		•		•1)
	A2 (B)			•	•1)	•1)	•1)	•	•1)		•		•		•1)
RR4000	L2			•	•1)	•1)	•1)	•	•1)		•		•		•1)
	L3		■		•	•	•		•					○	•
	L4		■		•	•	•		•					○	•
	A2 (A)			•	•1)	•1)	•1)	•	•1)		•		•		•1)
	A2 (B)			•	•1)	•1)	•1)	•	•1)		•		•		•1)
RR5200	L2			•	•1)	•1)	•1)	•	•1)		•		•		•1)
	L3		■		•	•	•		•					○	•
	L4		■		•	•	•		•					○	•
	A2 (A)			•	•1)	•1)	•1)	•	•1)		•		•		•1)
	A2 (B)			•	•1)	•1)	•1)	•	•1)		•		•		•1)
RR6500	L3			•	•1)	•1)	•1)	•	•1)		•		•		•1)
	L4		■		•	•	•		•					○	•
	A3 (A)			•	•1)	•1)	•1)	•	•1)		•		•		•1)
	A3 (B)			•	•1)	•1)	•1)	•	•1)		•		•		•1)
	A4			•	•1)	•1)	•1)	•	•1)		•		•		•1)
RR8000	L3			•	•1)	•1)	•1)	•	•1)		•		•		•1)
	L4		■		•	•	•		•					○	•
	A3 (A)			•	•1)	•1)	•1)	•	•1)		•		•		•1)
	A3 (B)			•	•1)	•1)	•1)	•	•1)		•		•		•1)
	A4 (A)			•	•1)	•1)	•1)	•	•1)		•		•		•1)
RR10000	L3			•	•1)	•1)	•1)	•	•1)		•		•		•1)
	L4		■		•	•	•		•					○	•
	A3 (A)			•	•1)	•1)	•1)	•	•1)		•		•		•1)
	A3 (B)			•	•1)	•1)	•1)	•	•1)		•		•		•1)
	A4 (A)			•	•1)	•1)	•1)	•	•1)		•		•		•1)
RR15000	L3			•	•1)	•1)	•1)	•	•1)		•		•		•1)
	L4		■		•	•	•		•					○	•
	A3 (A)			•	•1)	•1)	•1)	•	•1)		•		•		•1)
	A3 (B)			•	•1)	•1)	•1)	•	•1)		•		•		•1)
	A4 (A)			•	•1)	•1)	•1)	•	•1)		•		•		•1)
RR20000	L4			•	•1)	•1)	•1)	•	•1)		•		•		•1)
	A4 (A)			•	•1)	•1)	•1)	•	•1)		•		•		•1)
	A4 (B)			•	•1)	•1)	•1)	•	•1)		•		•		•1)
	A4 (C)			•	•1)	•1)	•1)	•	•1)		•		•		•1)
	A4 (B)			•	•1)	•1)	•1)	•	•1)		•		•		•1)
RR25000	L4			•	•1)	•1)	•1)	•	•1)		•		•		•1)
	A4 (A)			•	•1)	•1)	•1)	•	•1)		•		•		•1)
	A4 (B)			•	•1)	•1)	•1)	•	•1)		•		•		•1)
	A4 (C)			•	•1)	•1)	•1)	•	•1)		•		•		•1)
	A4 (B)			•	•1)	•1)	•1)	•	•1)		•		•		•1)
RR30000	L4			•	•1)	•1)	•1)	•	•1)		•		•		•1)
	A4 (A)			•	•1)	•1)	•1)	•	•1)		•		•		•1)
	A4 (B)			•	•1)	•1)	•1)	•	•1)		•		•		•1)
	A4 (C)			•	•1)	•1)	•1)	•	•1)		•		•		•1)
	A4 (B)			•	•1)	•1)	•1)	•	•1)		•		•		•1)
RR40000	L4			•	•1)	•1)	•1)	•	•1)		•		•		•1)
	A4 (A)			•	•1)	•1)	•1)	•	•1)		•		•		•1)
	A4 (B)			•	•1)	•1)	•1)	•	•1)		•		•		•1)
	A4 (C)			•	•1)	•1)	•1)	•	•1)		•		•		•1)
	A4 (B)			•	•1)	•1)	•1)	•	•1)		•		•		•1)
RF2/...		•		•	•	•		•		•		•		•	
RF5/...-RFF5/...		•		•	•	•		•		•		•		•	
RF170÷290			•	•1)	•1)	•1)	•	•1)		•		•		•1)	

• Ingresso standard / Standard input / Standardeingang / Entrée standard / Entrada standard / Entrada padrão (—)
 ■ Predisposizione RF / RF Setup / Auslegung RF / Préréglage RF / Predisposición RF / Predisposição RF
 ○ Predisposizione BOC / BOC Setup / Auslegung BOC / Préréglage BOC / Predisposición BOC / Predisposição BOC
 1) Con / With / Mit / Avec / Con / Com **KIT CB01**

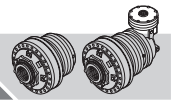

	SAUER DANFOSS																	
		OMM			OMP-OMR		OMP-OMR		OMP-OMR		OMP-OMR		OMP-OMR		OMP-OMR			
	Code	154-5975	154-5976	154-5977	154B2704	154B2706	154-5980	154B2708	154B2709	154-5978	154-2300M571	154B2707	154-5981	154B2711	154B2710	154-5979	154B2702	154B2700
X	28	28	25	23	44	41.5	57	36	25.5	23	44	25.5	36	57	25	23	44	
RR2500	L2	● 1)	● 1)	● 1)			● 1)		● 1)			● 1)			● 1)			
	L3	●	●	●		■		■			■			■			■	
	L4	●	●	●	■				■		■			■			■	
	A2 (A)	● 1)	● 1)	● 1)			● 1)			● 1)			● 1)			● 1)		
	A2 (B)	● 1)	● 1)	● 1)			● 1)			● 1)			● 1)			● 1)		
RR3200	L2	● 1)	● 1)	● 1)			● 1)		● 1)			● 1)			● 1)			
	L3	●	●	●		■		■			■			■			■	
	L4	●	●	●		■		■			■			■			■	
	A2 (A)	● 1)	● 1)	● 1)			● 1)			● 1)			● 1)			● 1)		
	A2 (B)	● 1)	● 1)	● 1)			● 1)			● 1)			● 1)			● 1)		
RR4000	L2	● 1)	● 1)	● 1)			● 1)		● 1)			● 1)			● 1)			
	L3	●	●	●		■		■			■			■			■	
	L4	●	●	●		■		■			■			■			■	
	A2 (A)	● 1)	● 1)	● 1)			● 1)			● 1)			● 1)			● 1)		
	A2 (B)	● 1)	● 1)	● 1)			● 1)			● 1)			● 1)			● 1)		
RR5200	L2	● 1)	● 1)	● 1)			● 1)		● 1)			● 1)			● 1)			
	L3	●	●	●		■		■			■			■			■	
	L4	●	●	●		■		■			■			■			■	
	A2 (A)	● 1)	● 1)	● 1)			● 1)			● 1)			● 1)			● 1)		
	A2 (B)	● 1)	● 1)	● 1)			● 1)			● 1)			● 1)			● 1)		
RR6500	L3	● 1)	● 1)	● 1)			● 1)		● 1)			● 1)			● 1)			
	L4	●	●	●		■		■			■			■			■	
	A3 (A)	● 1)	● 1)	● 1)			● 1)			● 1)			● 1)			● 1)		
	A3 (B)	● 1)	● 1)	● 1)			● 1)			● 1)			● 1)			● 1)		
	A4	●	●	●			●			●			●			●		
RR8000	L3	● 1)	● 1)	● 1)			● 1)		● 1)			● 1)			● 1)			
	L4	●	●	●		■		■			■			■			■	
	A3 (A)	● 1)	● 1)	● 1)			● 1)			● 1)			● 1)			● 1)		
	A3 (B)	● 1)	● 1)	● 1)			● 1)			● 1)			● 1)			● 1)		
	A4 (A)	●	●	●			●			●			●			●		
RR10000	L3	● 1)	● 1)	● 1)			● 1)		● 1)			● 1)			● 1)			
	L4	●	●	●		■		■			■			■			■	
	A3 (A)	● 1)	● 1)	● 1)			● 1)			● 1)			● 1)			● 1)		
	A3 (B)	● 1)	● 1)	● 1)			● 1)			● 1)			● 1)			● 1)		
	A4 (A)	●	●	●			●			●			●			●		
RR15000	L3	● 1)	● 1)	● 1)			● 1)		● 1)			● 1)			● 1)			
	L4	●	●	●		■		■			■			■			■	
	A3 (A)	● 1)	● 1)	● 1)			● 1)			● 1)			● 1)			● 1)		
	A3 (B)	● 1)	● 1)	● 1)			● 1)			● 1)			● 1)			● 1)		
	A4 (A)	●	●	●			●			●			●			●		
RR20000	L4	● 1)	● 1)	● 1)			● 1)		● 1)			● 1)			● 1)			
	A4 (A)	● 1)	● 1)	● 1)			● 1)		● 1)			● 1)			● 1)			
	A4 (B)	● 1)	● 1)	● 1)			● 1)		● 1)			● 1)			● 1)			
RR25000	L4	● 1)	● 1)	● 1)			● 1)		● 1)			● 1)			● 1)			
	A4 (A)	● 1)	● 1)	● 1)			● 1)		● 1)			● 1)			● 1)			
RR30000	L4	● 1)	● 1)	● 1)			● 1)		● 1)			● 1)			● 1)			
	A4 (A)	● 1)	● 1)	● 1)			● 1)		● 1)			● 1)			● 1)			
RR40000	L4	● 1)	● 1)	● 1)			● 1)		● 1)			● 1)			● 1)			
	A4 (A)	● 1)	● 1)	● 1)			● 1)		● 1)			● 1)			● 1)			
RF2/...	●	●	●			●			●			●			●			
RF5/...-RFF5/...	●	●	●			●			●			●			●			
RF170÷290	● 1)	● 1)	● 1)			● 1)			● 1)			● 1)			● 1)			

● Ingresso standard / Standard input / Standardeingang / Entrée standard / Entrada standard / Entrada padrão (—)
 ■ Predisposizione RF / RF Setup / Auslegung RF / Préréglage RF / Predisposición RF / Predisposição RF
 ○ Predisposizione BOC / BOC Setup / Auslegung BOC / Préréglage BOC / Predisposición BOC / Predisposição BOC
 1) Con / With / Mit / Avec / Con / Com **KIT CB01**

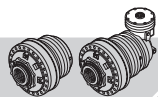

		SAUER DANFOSS																		
		OMS 12/24 z14			OMS ø32			OMSS 12/24 z12			OMT ø 40		OMTS 12/24 z16			OMV ø 50		OMYS 10/20 z16		
		Code	154F3442	154F3441	154-2256	154B2688	154B2691	154B2692	154F3443	154F3446	154B2690	154-2258M1	154-2267	154B2693	154B9758	154F3444	154F3445	154B2689	154-2263	154B2694
X	38	38	37	37	24	16.7	105	102	48	48	51	27.7	51	113	110	55	58	34.7	58	
RR2500	L2	● 1)	● 1)	● 1)				○	●	■		○			○	●	●			
	L3	●	●		■												■			
	L4	●	●			■					○									
	A2 (A)	● 1)	● 1)	● 1)					●			●				●		●		
	A2 (B)	● 1)	● 1)	● 1)					●			●				●		●		
A3	●	●				■						■							■	
A4	●	●	●										■							
RR3200	L2	● 1)	● 1)	● 1)				○	●	■					○	●	●	●		
	L3	●	●		■												■			
	L4	●	●			■														
	A2 (A)	● 1)	● 1)	● 1)					●			●				●		●		
	A2 (B)	● 1)	● 1)	● 1)					●			●				●		●		
A3 (A)	●	●				■						■							■	
A3 (B)	● 1)	● 1)	● 1)					●			●				●		●			
A4	●	●	●									■								
RR4000	L2	● 1)	● 1)	● 1)				○	●	■					○	●	●	●		
	L3	●	●		■												■			
	L4	●	●			■														
	A2 (A)	● 1)	● 1)	● 1)					●			●				●		●		
	A2 (B)	● 1)	● 1)	● 1)					●			●				●		●		
A3 (A)	●	●				■						■							■	
A3 (B)	● 1)	● 1)	● 1)					●			●				●		●			
A4	●	●	●									■								
RR5200	L2	● 1)	● 1)	● 1)				○	●	■					○	●	●	●		
	L3	●	●		■												■			
	L4	●	●			■														
	A2 (A)	● 1)	● 1)	● 1)					●			●				●		●		
	A2 (B)	● 1)	● 1)	● 1)					●			●				●		●		
A3 (A)	●	●				■						■							■	
A3 (B)	● 1)	● 1)	● 1)					●			●				●		●			
A3 (C)	● 1)	● 1)	● 1)					●			●				●		●			
A4	●	●	●									■								
RR6500	L3	● 1)	● 1)	● 1)				○	●	■					○	●	●	●		
	L4	●	●		■												■			
	A3 (A)	● 1)	● 1)	● 1)					●			●				●		●		
	A3 (B)	● 1)	● 1)	● 1)					●			●				●		●		
	A4	●	●	●									■							
RR8000	L3	● 1)	● 1)	● 1)				○	●	■					○	●	●	●		
	L4	●	●		■												■			
	A3 (A)	● 1)	● 1)	● 1)					●			●				●		●		
	A3 (B)	● 1)	● 1)	● 1)					●			●				●		●		
	A4 (A)	●	●				■						■							■
A4 (B)	● 1)	● 1)	● 1)					●			●				●		●			
RR10000	L3	● 1)	● 1)	● 1)				○	●	■					○	●	●	●		
	L4	●	●		■												■			
	A3 (A)	● 1)	● 1)	● 1)					●			●				●		●		
	A3 (B)	● 1)	● 1)	● 1)					●			●				●		●		
	A4 (A)	●	●				■						■							■
A4 (B)	● 1)	● 1)	● 1)					●			●				●		●			
RR15000	L3	● 1)	● 1)	● 1)				○	●	■					○	●	●	●		
	L4	●	●		■												■			
	A3 (A)	● 1)	● 1)	● 1)					●			●				●		●		
	A3 (B)	● 1)	● 1)	● 1)					●			●				●		●		
	A4 (A)	●	●				■						■							■
A4 (B)	● 1)	● 1)	● 1)					●			●				●		●			
A4 (C)	● 1)	● 1)	● 1)					●			●				●		●			
RR20000	L4	● 1)	● 1)	● 1)																
	A4 (A)	● 1)	● 1)	● 1)					●			●				●		●		
A4 (B)	● 1)	● 1)	● 1)					●			●				●		●			
RR25000	L4	● 1)	● 1)	● 1)																
	A4 (A)	● 1)	● 1)	● 1)					●			●				●		●		
A4 (B)	● 1)	● 1)	● 1)					●			●				●		●			
RR30000	L4	● 1)	● 1)	● 1)																
	A4 (A)	● 1)	● 1)	● 1)					●			●				●		●		
A4 (B)	● 1)	● 1)	● 1)					●			●				●		●			
RR40000	L4	● 1)	● 1)	● 1)																
	A4 (A)	● 1)	● 1)	● 1)					●			●				●		●		
A4 (B)	● 1)	● 1)	● 1)					●			●				●		●			
RF2/...	●	●	●																	
RF5/...-RFF5/...	●	●	●																	
RF170÷290	● 1)	● 1)	● 1)						●					●		●				●

- Ingresso standard / Standard input / Standardeingang / Entrée standard / Entrada standard / Entrada padrão (—)
 - Predisposizione RF / RF Setup / Auslegung RF / Préréglage RF / Predisposición RF / Predisposição RF
 - Predisposizione BOC / BOC Setup / Auslegung BOC / Préréglage BOC / Predisposición BOC / Predisposição BOC
- 1) Con / With / Mit / Avec / Con / Com **KIT CB01**

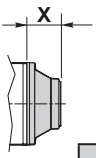

	CALZONI										CHAR-LYNN (EATON)					
	MR 190 N		MR 300 N		MR 450 N		MR 700 N	MR 1100 N	MRV 450		MRV 700	SERIE 2000 SAE A 2B 12/24 Z14	SERIE 2000 SAE A 4B 12/24 Z14	SERIE 2000 SAE A 2B ø1 1/4"	SERIE 2000 BEARING- LESS 12/24 z12	SERIE 6000 SAE C 2/4B 12/24 z17
	Code	154-2300M109	154-2300M156	154-2300M206	154-2300M157	154-2300M204	154-2300M205	154-2300M207	154-2300M373	154-2300M415	154-2300M374	154-2300M734	154-2300M553	154-2300M220	154-2300M457	154-2300M111
X	50	70	67.5	91	85.5	90	104	30	98	33	40	38	41	37	47.5	
RR2500	L2	• 1)		•		•	•	•		•	• 1)	• 1)	• 1)	• 1)	• 1)	
	L3		○		○				○							
	L4	•									•	•	•	•	•	
	A2 (A)	• 1)		•		•	•	•	•	•	•	• 1)	• 1)	• 1)	• 1)	
	A2 (B)	• 1)		•		•	•	•	•	•	•	• 1)	• 1)	• 1)	• 1)	
RR3200	L2	• 1)		•		•	•	•		•	• 1)	• 1)	• 1)	• 1)	• 1)	
	L3	•	○		○				○		•	•	•	•	•	
	L4	•	○		○				○		•	•	•	•	•	
	A2 (A)	• 1)		•		•	•	•	•	•	• 1)	• 1)	• 1)	• 1)	• 1)	
	A2 (B)	• 1)		•		•	•	•	•	•	• 1)	• 1)	• 1)	• 1)	• 1)	
RR4000	L2	• 1)		•		•	•	•		•	• 1)	• 1)	• 1)	• 1)	• 1)	
	L3	•	○		○				○		•	•	•	•	•	
	L4	•	○		○				○		•	•	•	•	•	
	A2 (A)	• 1)		•		•	•	•	•	•	• 1)	• 1)	• 1)	• 1)	• 1)	
	A2 (B)	• 1)		•		•	•	•	•	•	• 1)	• 1)	• 1)	• 1)	• 1)	
RR5200	L2	• 1)		•		•	•	•		•	• 1)	• 1)	• 1)	• 1)	• 1)	
	L3	•	○		○				○		•	•	•	•	•	
	L4	•	○		○				○		•	•	•	•	•	
	A2 (A)	• 1)		•		•	•	•	•	•	• 1)	• 1)	• 1)	• 1)	• 1)	
	A2 (B)	• 1)		•		•	•	•	•	•	• 1)	• 1)	• 1)	• 1)	• 1)	
RR6500	L2	• 1)		•		•	•	•		•	• 1)	• 1)	• 1)	• 1)	• 1)	
	L3	•	○		○				○		•	•	•	•	•	
	L4	•	○		○				○		•	•	•	•	•	
	A3 (A)	• 1)		•		•	•	•	•	•	• 1)	• 1)	• 1)	• 1)	• 1)	
	A3 (B)	• 1)		•		•	•	•	•	•	• 1)	• 1)	• 1)	• 1)	• 1)	
RR8000	L2	• 1)		•		•	•	•		•	• 1)	• 1)	• 1)	• 1)	• 1)	
	L3	•	○		○				○		•	•	•	•	•	
	L4	•	○		○				○		•	•	•	•	•	
	A3 (A)	• 1)		•		•	•	•	•	•	• 1)	• 1)	• 1)	• 1)	• 1)	
	A3 (B)	• 1)		•		•	•	•	•	•	• 1)	• 1)	• 1)	• 1)	• 1)	
RR10000	L2	• 1)		•		•	•	•		•	• 1)	• 1)	• 1)	• 1)	• 1)	
	L3	•	○		○				○		•	•	•	•	•	
	L4	•	○		○				○		•	•	•	•	•	
	A3 (A)	• 1)		•		•	•	•	•	•	• 1)	• 1)	• 1)	• 1)	• 1)	
	A3 (B)	• 1)		•		•	•	•	•	•	• 1)	• 1)	• 1)	• 1)	• 1)	
RR15000	L2	• 1)		•		•	•	•		•	• 1)	• 1)	• 1)	• 1)	• 1)	
	L3	•	○		○				○		•	•	•	•	•	
	L4	•	○		○				○		•	•	•	•	•	
	A3 (A)	• 1)		•		•	•	•	•	•	• 1)	• 1)	• 1)	• 1)	• 1)	
	A3 (B)	• 1)		•		•	•	•	•	•	• 1)	• 1)	• 1)	• 1)	• 1)	
RR20000	L4	• 1)		•		•	•	•		•	• 1)	• 1)	• 1)	• 1)	• 1)	
	A4 (A)	• 1)		•		•	•	•	•	•	• 1)	• 1)	• 1)	• 1)	• 1)	
	A4 (B)	• 1)		•		•	•	•	•	•	• 1)	• 1)	• 1)	• 1)	• 1)	
RR25000	L4	• 1)		•		•	•	•		•	• 1)	• 1)	• 1)	• 1)	• 1)	
	A4 (A)	• 1)		•		•	•	•	•	•	• 1)	• 1)	• 1)	• 1)	• 1)	
	A4 (B)	• 1)		•		•	•	•	•	•	• 1)	• 1)	• 1)	• 1)	• 1)	
RR30000	L4	• 1)		•		•	•	•		•	• 1)	• 1)	• 1)	• 1)	• 1)	
	A4 (A)	• 1)		•		•	•	•	•	•	• 1)	• 1)	• 1)	• 1)	• 1)	
	A4 (B)	• 1)		•		•	•	•	•	•	• 1)	• 1)	• 1)	• 1)	• 1)	
RR40000	L4	• 1)		•		•	•	•		•	• 1)	• 1)	• 1)	• 1)	• 1)	
	A4 (A)	• 1)		•		•	•	•	•	•	• 1)	• 1)	• 1)	• 1)	• 1)	
	A4 (B)	• 1)		•		•	•	•	•	•	• 1)	• 1)	• 1)	• 1)	• 1)	
RF2/...	•										•	•	•	•		
RF5/...-RFF5/...	•										•	•	•	•		
RF170÷290	• 1)		•		•	•	•	•		•	• 1)	• 1)	• 1)	• 1)	• 1)	

- Ingresso standard / Standard input / Standardeingang / Entrée standard / Entrada standard / Entrada padrão (—)
 - Predisposizione RF / RF Setup / Auslegung RF / Préréglage RF / Predisposición RF / Predisposição RF
 - Predisposizione BOC / BOC Setup / Auslegung BOC / Préréglage BOC / Predisposición BOC / Predisposição BOC
- 1) Con / With / Mit / Avec / Con / Com **KIT CB01**

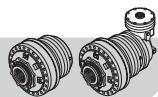

	DINAMIC OIL		LINDE						OLIOSTIP			
	AH 100 BH150/175/200	CH 250 DH 300	MMF 43 16/32 z15	MMF 63 12/24 z14	HMF 28-35	HMF 50-75 HMV 75	HMF 105 HMV 105	HMF 135 HMV 135	RMF 100-150	RMF 200-300	RMF 400-600	
	Code 154-2300M101	154-2300M103	154-2300M283	154-2300M302	154-2300M283	154-2300M300	154-2300M299	154-2300M394	154-2300M52	154-2300M51	154-2300M211	154-2300M202
X	50	50	24	31.5	24	31.5	31.5	124	50	50	64.5	75
RR2500	L2	• 1)	• 1)	• 1)	• 1)	• 1)	• 1)	• 1)	• 1)	•	•	•
	L3	•	•	•	•	•	•	•	•	•	•	•
	L4	•	•	•	•	•	•	•	•	•	•	•
	A2 (A)	• 1)	• 1)	• 1)	• 1)	• 1)	• 1)	• 1)	• 1)	•	•	•
	A2 (B)	• 1)	• 1)	• 1)	• 1)	• 1)	• 1)	• 1)	• 1)	•	•	•
	A3	•	•	•	•	•	•	•	•	•	•	•
RR3200	L2	• 1)	• 1)	• 1)	• 1)	• 1)	• 1)	• 1)	• 1)	•	•	•
	L3	•	•	•	•	•	•	•	•	•	•	•
	L4	•	•	•	•	•	•	•	•	•	•	•
	A2 (A)	• 1)	• 1)	• 1)	• 1)	• 1)	• 1)	• 1)	• 1)	•	•	•
	A2 (B)	• 1)	• 1)	• 1)	• 1)	• 1)	• 1)	• 1)	• 1)	•	•	•
	A3 (A)	•	•	•	•	•	•	•	•	•	•	•
RR4000	L2	• 1)	• 1)	• 1)	• 1)	• 1)	• 1)	• 1)	• 1)	•	•	•
	L3	•	•	•	•	•	•	•	•	•	•	•
	L4	•	•	•	•	•	•	•	•	•	•	•
	A2 (A)	• 1)	• 1)	• 1)	• 1)	• 1)	• 1)	• 1)	• 1)	•	•	•
	A2 (B)	• 1)	• 1)	• 1)	• 1)	• 1)	• 1)	• 1)	• 1)	•	•	•
	A3 (A)	•	•	•	•	•	•	•	•	•	•	•
RR5200	L2	• 1)	• 1)	• 1)	• 1)	• 1)	• 1)	• 1)	• 1)	•	•	•
	L3	•	•	•	•	•	•	•	•	•	•	•
	L4	•	•	•	•	•	•	•	•	•	•	•
	A2 (A)	• 1)	• 1)	• 1)	• 1)	• 1)	• 1)	• 1)	• 1)	•	•	•
	A2 (B)	• 1)	• 1)	• 1)	• 1)	• 1)	• 1)	• 1)	• 1)	•	•	•
	A3 (A)	•	•	•	•	•	•	•	•	•	•	•
RR6500	L2	• 1)	• 1)	• 1)	• 1)	• 1)	• 1)	• 1)	• 1)	•	•	•
	L3	•	•	•	•	•	•	•	•	•	•	•
	L4	•	•	•	•	•	•	•	•	•	•	•
	A3 (A)	• 1)	• 1)	• 1)	• 1)	• 1)	• 1)	• 1)	• 1)	•	•	•
	A3 (B)	• 1)	• 1)	• 1)	• 1)	• 1)	• 1)	• 1)	• 1)	•	•	•
	A4	•	•	•	•	•	•	•	•	•	•	•
RR8000	L2	• 1)	• 1)	• 1)	• 1)	• 1)	• 1)	• 1)	• 1)	•	•	•
	L3	•	•	•	•	•	•	•	•	•	•	•
	L4	•	•	•	•	•	•	•	•	•	•	•
	A3 (A)	• 1)	• 1)	• 1)	• 1)	• 1)	• 1)	• 1)	• 1)	•	•	•
	A3 (B)	• 1)	• 1)	• 1)	• 1)	• 1)	• 1)	• 1)	• 1)	•	•	•
	A4 (A)	•	•	•	•	•	•	•	•	•	•	•
RR10000	L2	• 1)	• 1)	• 1)	• 1)	• 1)	• 1)	• 1)	• 1)	•	•	•
	L3	•	•	•	•	•	•	•	•	•	•	•
	L4	•	•	•	•	•	•	•	•	•	•	•
	A3 (A)	• 1)	• 1)	• 1)	• 1)	• 1)	• 1)	• 1)	• 1)	•	•	•
	A3 (B)	• 1)	• 1)	• 1)	• 1)	• 1)	• 1)	• 1)	• 1)	•	•	•
	A4 (A)	•	•	•	•	•	•	•	•	•	•	•
RR15000	L2	• 1)	• 1)	• 1)	• 1)	• 1)	• 1)	• 1)	• 1)	•	•	•
	L3	•	•	•	•	•	•	•	•	•	•	•
	L4	•	•	•	•	•	•	•	•	•	•	•
	A3 (A)	• 1)	• 1)	• 1)	• 1)	• 1)	• 1)	• 1)	• 1)	•	•	•
	A3 (B)	• 1)	• 1)	• 1)	• 1)	• 1)	• 1)	• 1)	• 1)	•	•	•
	A4 (A)	•	•	•	•	•	•	•	•	•	•	•
RR20000	L2	• 1)	• 1)	• 1)	• 1)	• 1)	• 1)	• 1)	• 1)	•	•	•
	L3	•	•	•	•	•	•	•	•	•	•	•
	L4	•	•	•	•	•	•	•	•	•	•	•
	A4 (A)	• 1)	• 1)	• 1)	• 1)	• 1)	• 1)	• 1)	• 1)	•	•	•
	A4 (B)	• 1)	• 1)	• 1)	• 1)	• 1)	• 1)	• 1)	• 1)	•	•	•
	A4 (C)	•	•	•	•	•	•	•	•	•	•	•
RR25000	L2	• 1)	• 1)	• 1)	• 1)	• 1)	• 1)	• 1)	• 1)	•	•	•
	L3	•	•	•	•	•	•	•	•	•	•	•
	L4	•	•	•	•	•	•	•	•	•	•	•
	A4 (A)	• 1)	• 1)	• 1)	• 1)	• 1)	• 1)	• 1)	• 1)	•	•	•
	A4 (B)	• 1)	• 1)	• 1)	• 1)	• 1)	• 1)	• 1)	• 1)	•	•	•
	A4 (C)	•	•	•	•	•	•	•	•	•	•	•
RR30000	L2	• 1)	• 1)	• 1)	• 1)	• 1)	• 1)	• 1)	• 1)	•	•	•
	L3	•	•	•	•	•	•	•	•	•	•	•
	L4	•	•	•	•	•	•	•	•	•	•	•
	A4 (A)	• 1)	• 1)	• 1)	• 1)	• 1)	• 1)	• 1)	• 1)	•	•	•
	A4 (B)	• 1)	• 1)	• 1)	• 1)	• 1)	• 1)	• 1)	• 1)	•	•	•
	A4 (C)	•	•	•	•	•	•	•	•	•	•	•
RR40000	L2	• 1)	• 1)	• 1)	• 1)	• 1)	• 1)	• 1)	• 1)	•	•	•
	L3	•	•	•	•	•	•	•	•	•	•	•
	L4	•	•	•	•	•	•	•	•	•	•	•
	A4 (A)	• 1)	• 1)	• 1)	• 1)	• 1)	• 1)	• 1)	• 1)	•	•	•
	A4 (B)	• 1)	• 1)	• 1)	• 1)	• 1)	• 1)	• 1)	• 1)	•	•	•
	A4 (C)	•	•	•	•	•	•	•	•	•	•	•
RF2/...	•	•	•	•	•	•	•	•	•	•	•	
RF5/...-RFF5/...	•	•	•	•	•	•	•	•	•	•	•	
RF170±290	• 1)	• 1)	• 1)	• 1)	• 1)	• 1)	• 1)	• 1)	• 1)	•	•	•

• Ingresso standard / Standard input / Standardeingang / Entrée standard / Entrada standard / Entrada padrão (—)
 ■ Predisposizione RF / RF Setup / Auslegung RF / Préréglage RF / Predisposición RF / Predisposição RF
 ○ Predisposizione BOC / BOC Setup / Auslegung BOC / Préréglage BOC / Predisposición BOC / Predisposição BOC
 1) Con / With / Mit / Avec / Con / Com **KIT CB01**

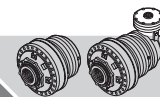

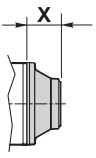
	SAI							
	GM05 28x34 UNI 8953	GM05 35x2 z16 DIN 5480	GM1 28x34 UNI 8953	GM1 35x2 z16 DIN 5480		GM2 36x40 UNI 8953	GM3 46x54 UNI 8953	GM4/GM5A 56x65 UNI 8953
	Code 154-2300M455	154-2300M624	154-2300M43	154-2300M506	154-2300M549	154-2300M321	154-2300M838	154-2300M742
X	37	37	20	20	61	63.5	84	84
RR2500	L2	• 1)	• 1)	• 1)	• 1)			
	L3	•	•	•	•			
	L4	•	•	•	•			
	A2 (A)	• 1)	• 1)	• 1)	• 1)			
	A2 (B)	• 1)	• 1)	• 1)	• 1)			
	A3	•	•	•	•			
RR3200	L2	• 1)	• 1)	• 1)	• 1)			
	L3	•	•	•	•			
	L4	•	•	•	•			
	A2 (A)	• 1)	• 1)	• 1)	• 1)			
	A2 (B)	• 1)	• 1)	• 1)	• 1)			
	A3 (A)	•	•	•	•			
RR4000	L2	• 1)	• 1)	• 1)	• 1)			
	L3	•	•	•	•			
	L4	•	•	•	•			
	A2 (A)	• 1)	• 1)	• 1)	• 1)			
	A2 (B)	• 1)	• 1)	• 1)	• 1)			
	A3 (A)	•	•	•	•			
RR5200	L2	• 1)	• 1)	• 1)	• 1)			
	L3	•	•	•	•			
	L4	•	•	•	•			
	A2 (A)	• 1)	• 1)	• 1)	• 1)			
	A2 (B)	• 1)	• 1)	• 1)	• 1)			
	A3 (A)	•	•	•	•			
RR6500	L2	• 1)	• 1)	• 1)	• 1)			
	L3	•	•	•	•			
	L4	•	•	•	•			
	A3 (A)	• 1)	• 1)	• 1)	• 1)			
	A3 (B)	• 1)	• 1)	• 1)	• 1)			
	A4	•	•	•	•			
RR8000	L2	• 1)	• 1)	• 1)	• 1)			
	L3	•	•	•	•			
	L4	•	•	•	•			
	A3 (A)	• 1)	• 1)	• 1)	• 1)			
	A3 (B)	• 1)	• 1)	• 1)	• 1)			
	A4 (A)	•	•	•	•			
RR10000	L2	• 1)	• 1)	• 1)	• 1)			
	L3	•	•	•	•			
	L4	•	•	•	•			
	A3 (A)	• 1)	• 1)	• 1)	• 1)			
	A3 (B)	• 1)	• 1)	• 1)	• 1)			
	A4 (A)	•	•	•	•			
RR15000	L2	• 1)	• 1)	• 1)	• 1)			
	L3	•	•	•	•			
	L4	•	•	•	•			
	A3 (A)	• 1)	• 1)	• 1)	• 1)			
	A3 (B)	• 1)	• 1)	• 1)	• 1)			
	A4 (A)	•	•	•	•			
RR20000	L2	• 1)	• 1)	• 1)	• 1)			
	L3	•	•	•	•			
	L4	•	•	•	•			
	A4 (A)	• 1)	• 1)	• 1)	• 1)			
	A4 (B)	• 1)	• 1)	• 1)	• 1)			
	A4 (C)	• 1)	• 1)	• 1)	• 1)			
RR25000	L4	• 1)	• 1)	• 1)	• 1)			
	A4 (A)	• 1)	• 1)	• 1)	• 1)			
RR30000	L4	• 1)	• 1)	• 1)	• 1)			
	A4 (A)	• 1)	• 1)	• 1)	• 1)			
RR40000	L4	• 1)	• 1)	• 1)	• 1)			
	A4 (A)	• 1)	• 1)	• 1)	• 1)			
RF2/...	•	•	•	•	•			
RF5/...-RFF5/...	•	•	•	•	•			
RF170÷290	• 1)	• 1)	• 1)	• 1)	•			

● Ingresso standard / Standard input / Standardeingang / Entrée standard / Entrada standard / Entrada padrão (—)
 ■ Predisposizione RF / RF Setup / Auslegung RF / Préréglage RF / Predisposición RF / Predisposição RF
 ○ Predisposizione BOC / BOC Setup / Auslegung BOC / Préréglage BOC / Predisposición BOC / Predisposição BOC
 1) Con / With / Mit / Avec / Con / Com **KIT CB01**

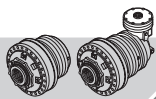

VOLVO (PARKER)

Code	F11-5 ø18	F11-10 ø20	F11-19 ø25	F11-28 ø25	F11-39-58 ø35	F11-78 ø45	F11-110 ø45	F11-110 40X2 Z18	F11-150 ø50	F11-150 45x2x21	F11-250 8/16 Z15	F12-30 ø30	F12-40 ø1 1/4"	F12-60 ø35	F12-80 ø40	F12-80 12/24 Z17			
	154-2300M11	154-2300M10	154-2300M13	154-2300M14	154-2300M12	154-2300M129	154-2300M131	154-2300M363	154-2300M130	154-2300M132	154-2300M473	154-2300M854	154-2300M591	154-2300M483	154-2300M594	154-2300M612	154-2300M481	154-2300M658	
X	24	30	38	24	62	110	110	64	120	117	173	120	121	46	46	62	103	31.5	
RR2500	L2	• 1)	• 1)	• 1)	• 1)	• 1)		• 1)		•		• 1)	• 1)	• 1)		• 1)		• 1)	
	L3	•	•	•	•	•	○	•	○	•		•	•	•	■	•	○	•	
	L4	•	•	•	•	•		•			•		•	•	•	•	•	•	
	A2 (A)	• 1)	• 1)	• 1)	• 1)	• 1)		• 1)		•		•	• 1)	• 1)	• 1)		• 1)		• 1)
	A2 (B)	• 1)	• 1)	• 1)	• 1)	• 1)		• 1)		•		•	• 1)	• 1)	• 1)		• 1)		• 1)
A3	•	•	•	•	•		•			•		•	•	•	•	•	•	•	
A4	•	•	•	•	•		•			•		•	•	•	•	•	•	•	
RR3200	L2	• 1)	• 1)	• 1)	• 1)	• 1)		• 1)		•		• 1)	• 1)	• 1)		• 1)		• 1)	
	L3	•	•	•	•	•	○	•	○	•		•	•	•	■	•	○	•	
	L4	•	•	•	•	•		•			•		•	•	•	•	•	•	
	A2 (A)	• 1)	• 1)	• 1)	• 1)	• 1)		• 1)		•		•	• 1)	• 1)	• 1)		• 1)		• 1)
	A2 (B)	• 1)	• 1)	• 1)	• 1)	• 1)		• 1)		•		•	• 1)	• 1)	• 1)		• 1)		• 1)
A3 (A)	•	•	•	•	•		•			•		•	•	•	•	•	•	•	
A3 (B)	• 1)	• 1)	• 1)	• 1)	• 1)		• 1)		•		•	• 1)	• 1)	• 1)		• 1)		• 1)	
A4	•	•	•	•	•		•			•		•	•	•	•	•	•	•	
RR4000	L2	• 1)	• 1)	• 1)	• 1)	• 1)		• 1)		•		• 1)	• 1)	• 1)		• 1)		• 1)	
	L3	•	•	•	•	•	○	•	○	•		•	•	•	■	•	○	•	
	L4	•	•	•	•	•		•			•		•	•	•	•	•	•	
	A2 (A)	• 1)	• 1)	• 1)	• 1)	• 1)		• 1)		•		•	• 1)	• 1)	• 1)		• 1)		• 1)
	A2 (B)	• 1)	• 1)	• 1)	• 1)	• 1)		• 1)		•		•	• 1)	• 1)	• 1)		• 1)		• 1)
A3 (A)	•	•	•	•	•		•			•		•	•	•	•	•	•	•	
A3 (B)	• 1)	• 1)	• 1)	• 1)	• 1)		• 1)		•		•	• 1)	• 1)	• 1)		• 1)		• 1)	
A4	•	•	•	•	•		•			•		•	•	•	•	•	•	•	
RR5200	L2	• 1)	• 1)	• 1)	• 1)	• 1)		• 1)		•		• 1)	• 1)	• 1)		• 1)		• 1)	
	L3	•	•	•	•	•	○	•	○	•		•	•	•	■	•	○	•	
	L4	•	•	•	•	•		•			•		•	•	•	•	•	•	
	A2 (A)	• 1)	• 1)	• 1)	• 1)	• 1)		• 1)		•		•	• 1)	• 1)	• 1)		• 1)		• 1)
	A2 (B)	• 1)	• 1)	• 1)	• 1)	• 1)		• 1)		•		•	• 1)	• 1)	• 1)		• 1)		• 1)
A3 (A)	•	•	•	•	•		•			•		•	•	•	•	•	•	•	
A3 (B)	• 1)	• 1)	• 1)	• 1)	• 1)		• 1)		•		•	• 1)	• 1)	• 1)		• 1)		• 1)	
A3 (C)	• 1)	• 1)	• 1)	• 1)	• 1)		• 1)		•		•	• 1)	• 1)	• 1)		• 1)		• 1)	
A4	•	•	•	•	•		•			•		•	•	•	•	•	•	•	
RR6500	L3	• 1)	• 1)	• 1)	• 1)	• 1)		• 1)		•		• 1)	• 1)	• 1)		• 1)		• 1)	
	L4	•	•	•	•	•	○	•	○	•		•	•	•	■	•	○	•	
	A3 (A)	• 1)	• 1)	• 1)	• 1)	• 1)		• 1)		•		•	• 1)	• 1)	• 1)		• 1)		• 1)
A3 (B)	• 1)	• 1)	• 1)	• 1)	• 1)		• 1)		•		•	• 1)	• 1)	• 1)		• 1)		• 1)	
A4	•	•	•	•	•		•			•		•	•	•	•	•	•	•	
RR8000	L3	• 1)	• 1)	• 1)	• 1)	• 1)		• 1)		•		• 1)	• 1)	• 1)		• 1)		• 1)	
	L4	•	•	•	•	•	○	•	○	•		•	•	•	■	•	○	•	
	A3 (A)	• 1)	• 1)	• 1)	• 1)	• 1)		• 1)		•		•	• 1)	• 1)	• 1)		• 1)		• 1)
	A3 (B)	• 1)	• 1)	• 1)	• 1)	• 1)		• 1)		•		•	• 1)	• 1)	• 1)		• 1)		• 1)
A4 (A)	•	•	•	•	•		•			•		•	•	•	•	•	•	•	
A4 (B)	• 1)	• 1)	• 1)	• 1)	• 1)		• 1)		•		•	• 1)	• 1)	• 1)		• 1)		• 1)	
RR10000	L3	• 1)	• 1)	• 1)	• 1)	• 1)		• 1)		•		• 1)	• 1)	• 1)		• 1)		• 1)	
	L4	•	•	•	•	•	○	•	○	•		•	•	•	■	•	○	•	
	A3 (A)	• 1)	• 1)	• 1)	• 1)	• 1)		• 1)		•		•	• 1)	• 1)	• 1)		• 1)		• 1)
	A3 (B)	• 1)	• 1)	• 1)	• 1)	• 1)		• 1)		•		•	• 1)	• 1)	• 1)		• 1)		• 1)
A4 (A)	•	•	•	•	•		•			•		•	•	•	•	•	•	•	
A4 (B)	• 1)	• 1)	• 1)	• 1)	• 1)		• 1)		•		•	• 1)	• 1)	• 1)		• 1)		• 1)	
RR15000	L3	• 1)	• 1)	• 1)	• 1)	• 1)		• 1)		•		• 1)	• 1)	• 1)		• 1)		• 1)	
	L4	•	•	•	•	•	○	•	○	•		•	•	•	■	•	○	•	
	A3 (A)	• 1)	• 1)	• 1)	• 1)	• 1)		• 1)		•		•	• 1)	• 1)	• 1)		• 1)		• 1)
	A3 (B)	• 1)	• 1)	• 1)	• 1)	• 1)		• 1)		•		•	• 1)	• 1)	• 1)		• 1)		• 1)
A4 (A)	•	•	•	•	•		•			•		•	•	•	•	•	•	•	
A4 (B)	• 1)	• 1)	• 1)	• 1)	• 1)		• 1)		•		•	• 1)	• 1)	• 1)		• 1)		• 1)	
A4 (C)	• 1)	• 1)	• 1)	• 1)	• 1)		• 1)		•		•	• 1)	• 1)	• 1)		• 1)		• 1)	
RR20000	L4	• 1)	• 1)	• 1)	• 1)	• 1)		• 1)		•		• 1)	• 1)	• 1)		• 1)		• 1)	
	A4 (A)	• 1)	• 1)	• 1)	• 1)	• 1)		• 1)		•		•	• 1)	• 1)	• 1)		• 1)		• 1)
A4 (B)	• 1)	• 1)	• 1)	• 1)	• 1)		• 1)		•		•	• 1)	• 1)	• 1)		• 1)		• 1)	
RR25000	L4	• 1)	• 1)	• 1)	• 1)	• 1)		• 1)		•		• 1)	• 1)	• 1)		• 1)		• 1)	
	A4 (A)	• 1)	• 1)	• 1)	• 1)	• 1)		• 1)		•		•	• 1)	• 1)	• 1)		• 1)		• 1)
A4 (B)	• 1)	• 1)	• 1)	• 1)	• 1)		• 1)		•		•	• 1)	• 1)	• 1)		• 1)		• 1)	
RR30000	L4	• 1)	• 1)	• 1)	• 1)	• 1)		• 1)		•		• 1)	• 1)	• 1)		• 1)		• 1)	
	A4 (A)	• 1)	• 1)	• 1)	• 1)	• 1)		• 1)		•		•	• 1)	• 1)	• 1)		• 1)		• 1)
A4 (B)	• 1)	• 1)	• 1)	• 1)	• 1)		• 1)		•		•	• 1)	• 1)	• 1)		• 1)		• 1)	
RR40000	L4	• 1)	• 1)	• 1)	• 1)	• 1)		• 1)		•		• 1)	• 1)	• 1)		• 1)		• 1)	
	A4 (A)	• 1)	• 1)	• 1)	• 1)	• 1)		• 1)		•		•	• 1)	• 1)	• 1)		• 1)		• 1)
A4 (B)	• 1)	• 1)	• 1)	• 1)	• 1)		• 1)		•		•	• 1)	• 1)	• 1)		• 1)		• 1)	
RF2/...	•	•	•	•	•		•			•		•	•	•		•		•	
RF5/...-RFF5/...	•	•	•	•	•		•			•		•	•	•		•		•	
RF170÷290	• 1)	• 1)	• 1)	• 1)	• 1)		•			•		• 1)	• 1)	• 1)		• 1)		• 1)	

• Ingresso standard / Standard input / Standardeingang / Entrée standard / Entrada standard / Entrada padrão (—)
 ■ Predisposizione RF / RF Setup / Auslegung RF / Préréglage RF / Predisposición RF / Predisposição RF
 ○ Predisposizione BOC / BOC Setup / Auslegung BOC / Préréglage BOC / Predisposición BOC / Predisposição BOC
 1) Con / With / Mit / Avec / Con / Com **KIT CB01**

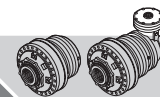

		IEC B5																																					
		63	71	80	90	100-112		132		160	180		200		225	250		315																					
Code		154-2300M367	154-2300M228	154-2300M229	154-2300M532	154-2300M230	154-2300M520	154-2300M231	154-2300M518	154-2300M584	154-2300M607	154-2300M232	154-2300M582	154-2300M585	154-2300M606	154-2300M456	154-2300M586	154-2300M235	154-2300M595	154-2300M744	154-2300M721	154-2300M442	154-2300M535	154-2300M496	154-2300M748	154-2300M676	154-2300M728	154-2300M526	154-2300M789										
X		18.5	18	24	32.5	24	32.5	30	32.5	52	52	97	62.5	75.5	75.5	128	104.8	128	105	115	141.5	141.5	161.7	134	190.7	151.5	151.5	151.5	161.5										
RR2500	L2	● 1)	● 1)	● 1)		● 1)		● 1)				● 1)			● 1)					●	■																		
	L3	●	●	●		●				■				■		■		■			■																		
	L4	●	●	●	■		■						■			●		●			●																		
	A2 (A)	● 1)	● 1)	● 1)		● 1)		● 1)				● 1)				● 1)					●				●														
	A2 (B)	● 1)	● 1)	● 1)		● 1)		● 1)				● 1)				● 1)					●				●														
	A3	●	●	●		●		●				●				●			●			■			■														
RR3200	L2	● 1)	● 1)	● 1)		● 1)		● 1)				● 1)			● 1)					●		■		●				■											
	L3	●	●	●		●				■				■		■		■			■																		
	L4	●	●	●		●					■				■		■		■		■																		
	A2 (A)	● 1)	● 1)	● 1)		● 1)		● 1)				● 1)				● 1)					●				●														
	A2 (B)	● 1)	● 1)	● 1)		● 1)		● 1)				● 1)				● 1)					●				●														
	A3 (A)	●	●	●		●		●				●				●			●			■			■														
RR4000	L2	● 1)	● 1)	● 1)		● 1)		● 1)				● 1)			● 1)					●		■		●				■											
	L3	●	●	●		●				■				■		■		■			■																		
	L4	●	●	●		●					■				■		■		■		■																		
	A2 (A)	● 1)	● 1)	● 1)		● 1)		● 1)				● 1)				● 1)					●				●														
	A2 (B)	● 1)	● 1)	● 1)		● 1)		● 1)				● 1)				● 1)					●				●														
	A3 (A)	●	●	●		●		●				●				●			●			■			■														
RR5200	L2	● 1)	● 1)	● 1)		● 1)		● 1)				● 1)			● 1)					●		■		●				■											
	L3	●	●	●		●				■				■		■		■			■																		
	L4	●	●	●		●					■				■		■		■		■																		
	A2 (A)	● 1)	● 1)	● 1)		● 1)		● 1)				● 1)				● 1)					●				●														
	A2 (B)	● 1)	● 1)	● 1)		● 1)		● 1)				● 1)				● 1)					●				●														
	A3 (A)	●	●	●		●		●				●				●			●			■			■														
RR6500	L3	● 1)	● 1)	● 1)		● 1)		● 1)				● 1)			● 1)					●		■		●				■											
	L4	●	●	●		●					■			■		■		■			■																		
	A3 (A)	● 1)	● 1)	● 1)		● 1)		● 1)				● 1)			● 1)					●				●															
	A3 (B)	● 1)	● 1)	● 1)		● 1)		● 1)				● 1)			● 1)						●				●														
	A4	●	●	●		●		●				●				●			●			■			■														
	RR8000	L3	● 1)	● 1)	● 1)		● 1)		● 1)				● 1)			● 1)					●		■		●				■										
L4		●	●	●		●					■			■		■		■			■																		
A3 (A)		● 1)	● 1)	● 1)		● 1)		● 1)				● 1)			● 1)					●				●															
A3 (B)		● 1)	● 1)	● 1)		● 1)		● 1)				● 1)			● 1)						●				●														
A4 (A)		●	●	●		●		●				●				●			●			■			■														
A4 (B)		● 1)	● 1)	● 1)		● 1)		● 1)				● 1)			● 1)						●				●														
RR10000	L3	● 1)	● 1)	● 1)		● 1)		● 1)				● 1)			● 1)					●		■		●				■											
	L4	●	●	●		●					■			■		■		■			■																		
	A3 (A)	● 1)	● 1)	● 1)		● 1)		● 1)				● 1)			● 1)					●				●															
	A3 (B)	● 1)	● 1)	● 1)		● 1)		● 1)				● 1)			● 1)						●				●														
	A4 (A)	●	●	●		●		●				●				●			●			■			■														
	A4 (B)	● 1)	● 1)	● 1)		● 1)		● 1)				● 1)			● 1)						●				●														
RR15000	L3	● 1)	● 1)	● 1)		● 1)		● 1)				● 1)			● 1)					●		■		●				■											
	L4	●	●	●		●					■			■		■		■			■																		
	A3 (A)	● 1)	● 1)	● 1)		● 1)		● 1)				● 1)			● 1)					●				●															
	A3 (B)	● 1)	● 1)	● 1)		● 1)		● 1)				● 1)			● 1)						●				●														
	A4 (A)	●	●	●		●		●				●				●			●			■			■														
	A4 (B)	● 1)	● 1)	● 1)		● 1)		● 1)				● 1)			● 1)						●				●														
RR20000	L4	● 1)	● 1)	● 1)		● 1)		● 1)				● 1)			● 1)					●		■		●															
	A4 (A)	● 1)	● 1)	● 1)		● 1)		● 1)				● 1)			● 1)					●				●															
RR25000	L4	● 1)	● 1)	● 1)		● 1)		● 1)				● 1)			● 1)					●				●															
	A4 (A)	● 1)	● 1)	● 1)		● 1)		● 1)				● 1)			● 1)					●				●															
RR30000	L4	● 1)	● 1)</																																				

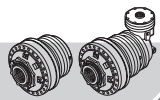

13 NORME PER L'INSTALLAZIONE

13 INSTALLATION INSTRUCTIONS

13 INSTALLATIONSVORSCHRIFTEN

13.1 Dimensioni suggerite per il montaggio

Di seguito sono indicate le dimensioni suggerite per il montaggio del riduttore alla macchina.

Prima del montaggio occorre pulire e sgrassare i piani di battuta e le superfici di centraggio (indicati con \triangle in figura), che devono essere esenti da verniciatura.

13.1 Recommended dimensions for assembly

The dimensions recommended for mounting the reduction gear on the machine are given below but before starting, the resting tops and centring surfaces must be cleaned and degreased (indicated with \triangle in the figure) and free of paint.

13.1 Empfohlene Abmessungen für die Montage

Es folgt eine Auflistung der Abmessungen, die für die Montage des Planetengetriebes an der Maschine empfohlen werden.

Vor der Montage müssen die Auflageflächen und die Zentrierflächen (auf der Abb. mit \triangle gekennzeichnet) sauber gemacht und entfettet werden. Sicherstellen, dass sie keine Lackreste aufweisen.

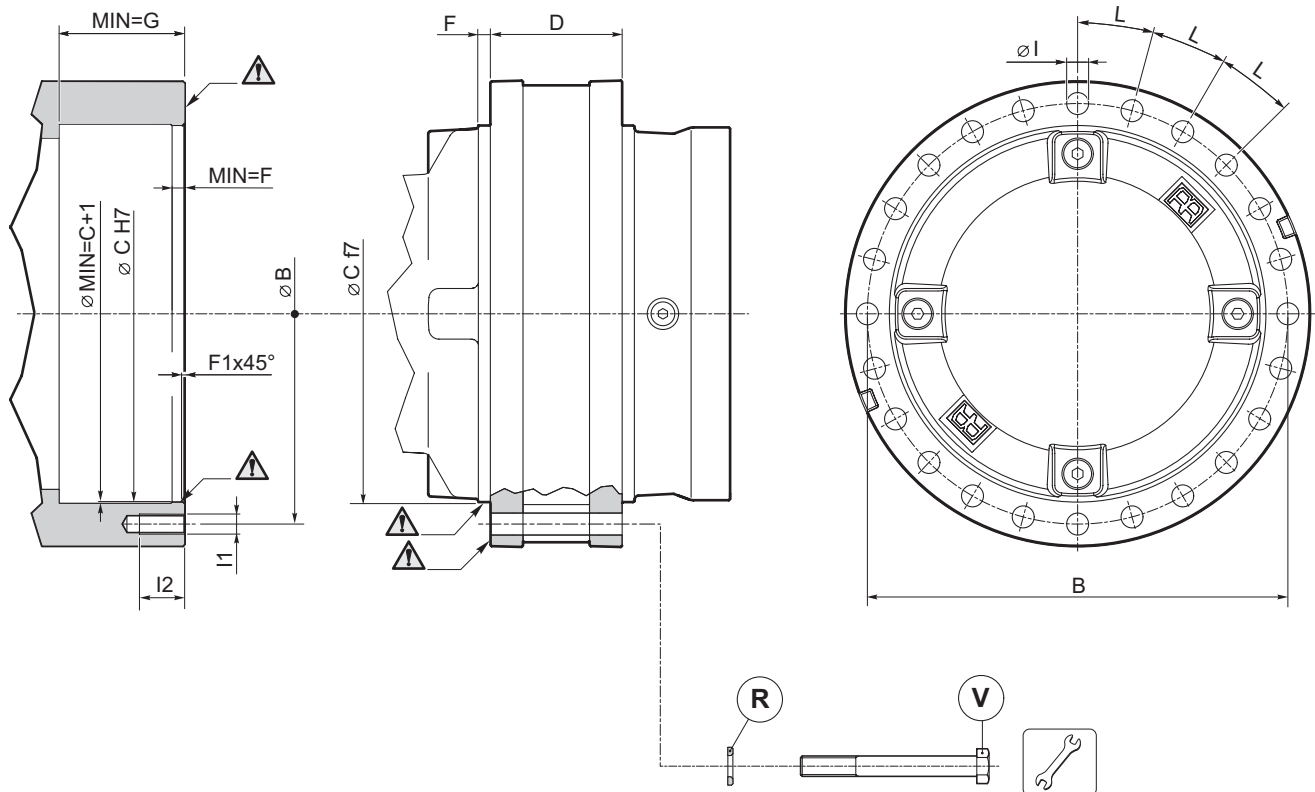

	B	C	D	F	F1	G		I	I1	I2 _{min}	L	R	V	 [Nm]
						MS/MC	FS							
RR2500	335	300	105	10	1.5	100	85	17.5 n°24	M16-6H	36	15°	UNI 5714-16 n°24	ISO 4014-M16x140-10.9 n°24	288
RR3200	370	335	105	10	1.5	115	100	17.5 n°24	M16-6H	36	15°	UNI 5714-16 n°24	ISO 4014-M16x140-10.9 n°24	288
RR4000	420	380	126	10	1.5	115	105	17.5 n°32	M16-6H	36	11.25°	UNI 5714-16 n°32	ISO 4014-M16x160-10.9 n°32	288
RR5200	420	380	126	10	1.5	125	105	17.5 n°32	M16-6H	36	11.25°	UNI 5714-16 n°32	ISO 4014-M16x160-10.9 n°32	288
RR6500	465	415	142	12	1.5	130	115	22 n°32	M20-6H	40	11.25°	UNI 5714-20 n°32	ISO 4014-M20x180-10.9 n°32	556
RR8000	515	460	155	12	1.5	150	145	26 n°32	M24-6H	60	11.25°	UNI 5714-24 n°32	ISO 4014-M24x210-10.9 n°32	980
RR10000	515	460	155	12	1.5	150	145	26 n°32	M24-6H	60	11.25°	UNI 5714-24 n°32	ISO 4014-M24x210-10.9 n°32	980
RR15000	590	535	180	15	1.5	—	155	26 n°32	M24-6H	55	11.25°	UNI 5714-24 n°32	ISO 4014-M24x230-10.9 n°32	980
RR20000	665	605	190	15	1.5	—	185	26 n°36	M24-6H	55	10°	UNI 5714-24 n°36	ISO 4014-M24x240-10.9 n°36	980
RR25000	750	675	205	18	1.5	—	225	33 n°36	M30-6H	68	10°	UNI 5714-30 n°36	ISO 4014-M30x270-10.9 n°36	2130
RR30000	830	750	240	20	2	—	250	33 n°36	M30-6H	65	10°	UNI 5714-30 n°36	ISO 4014-M30x300-10.9 n°36	2130
RR40000	830	750	240	20	2	—	250	33 n°36	M30-6H	65	10°	UNI 5714-30 n°36	ISO 4014-M30x300-10.9 n°36	2130
RR55000	920	830	280	21	2.5	—	270	39 n°36	M36-6H	90	10°	UNI 5714-36 n°36	ISO 4014-M36x360-10.9 n°36	3680

(1) Coefficiente d'attrito medio considerato: 0.14
Average friction coefficient considered: 0.14
Durchschnittlicher berücksichtigter Reibungskoeffizient: 0.14

Componenti non forniti da Reggiana Riduttori
Components not supplied by Reggiana Riduttori
Nicht von Reggiana Riduttori gelieferte Komponenten

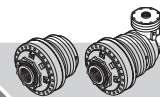

13.1 Dimensions recommandées pour le montage

13.1 Dimensiones sugeridas para el montaje

13.1 Dimensões sugeridas para a montagem

Ci-dessous figurent les dimensions recommandées pour le montage du réducteur à la machine.

Avant de monter le réducteur, nettoyer et dégraisser les surfaces de butée et les surfaces de centrage (indiquées par \triangle sur la figure), qui doivent être dépourvues de toute trace de peinture.

A continuación se indican las medidas sugeridas para el montaje del reductor en la máquina.

Antes de efectuar el montaje es necesario limpiar y desengrasar los planos de contacto y las superficies de centrado (indicados con \triangle en la figura), que no deben tener pintura.

A seguir estão indicadas as dimensões sugeridas para a montagem do redutor na máquina.

Antes da montagem é necessário limpar e desengordurar os planos de contato e as superfícies de centralização (indicados com \triangle na figura), que devem ser isentos de pintura.

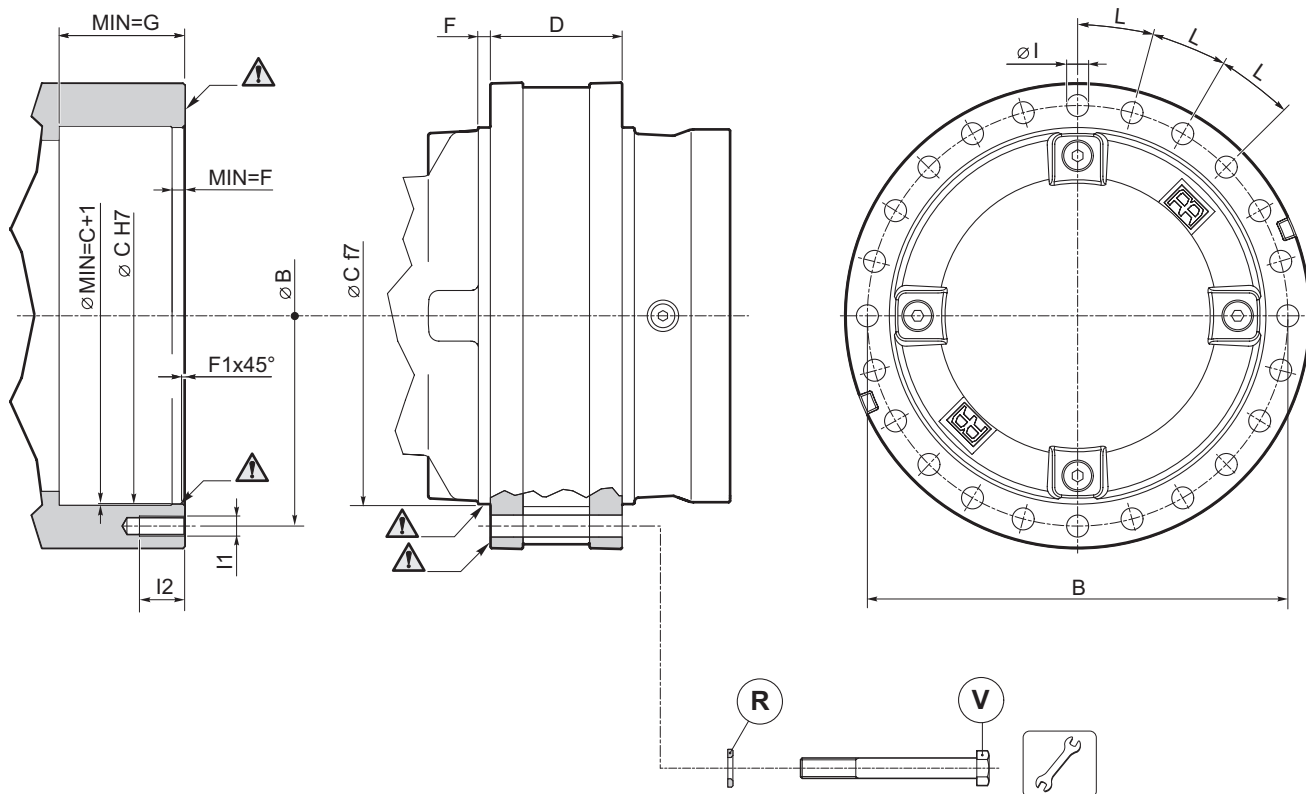

	B	C	D	F	F1	G		I	I1	I2 _{min}	L	R	V	 (1) [Nm]
						MS/MC	FS							
RR2500	335	300	105	10	1.5	100	85	17.5 n°24	M16-6H	36	15°	UNI 5714-16 n°24	ISO 4014-M16x140-10.9 n°24	288
RR3200	370	335	105	10	1.5	115	100	17.5 n°24	M16-6H	36	15°	UNI 5714-16 n°24	ISO 4014-M16x140-10.9 n°24	288
RR4000	420	380	126	10	1.5	115	105	17.5 n°32	M16-6H	36	11.25°	UNI 5714-16 n°32	ISO 4014-M16x160-10.9 n°32	288
RR5200	420	380	126	10	1.5	125	105	17.5 n°32	M16-6H	36	11.25°	UNI 5714-16 n°32	ISO 4014-M16x160-10.9 n°32	288
RR6500	465	415	142	12	1.5	130	115	22 n°32	M20-6H	40	11.25°	UNI 5714-20 n°32	ISO 4014-M20x180-10.9 n°32	556
RR8000	515	460	155	12	1.5	150	145	26 n°32	M24-6H	60	11.25°	UNI 5714-24 n°32	ISO 4014-M24x210-10.9 n°32	980
RR10000	515	460	155	12	1.5	150	145	26 n°32	M24-6H	60	11.25°	UNI 5714-24 n°32	ISO 4014-M24x210-10.9 n°32	980
RR15000	590	535	180	15	1.5	—	155	26 n°32	M24-6H	55	11.25°	UNI 5714-24 n°32	ISO 4014-M24x230-10.9 n°32	980
RR20000	665	605	190	15	1.5	—	185	26 n°36	M24-6H	55	10°	UNI 5714-24 n°36	ISO 4014-M24x240-10.9 n°36	980
RR25000	750	675	205	18	1.5	—	225	33 n°36	M30-6H	68	10°	UNI 5714-30 n°36	ISO 4014-M30x270-10.9 n°36	2130
RR30000	830	750	240	20	2	—	250	33 n°36	M30-6H	65	10°	UNI 5714-30 n°36	ISO 4014-M30x300-10.9 n°36	2130
RR40000	830	750	240	20	2	—	250	33 n°36	M30-6H	65	10°	UNI 5714-30 n°36	ISO 4014-M30x300-10.9 n°36	2130
RR55000	920	830	280	21	2.5	—	270	39 n°36	M36-6H	90	10°	UNI 5714-36 n°36	ISO 4014-M36x360-10.9 n°36	3680

(1) Coefficient de frottement moyen considéré : 0.14
 Coeficiente medio de fricción considerado: 0.14
 Coeficiente de atrito médio considerado: 0.14

Parties pas fournies par Reggiana Riduttori
 Componentes no suministrados por Reggiana Riduttori
 Componentes não fornecidos por Reggiana Riduttori

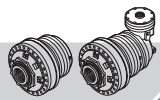

13.2 Calettatori per attrito

13.2 Friction shrink discs

13.2 Schrumpfscheiben

Prima di procedere con il montaggio del calettatore per attrito, occorre pulire e sgrassare accuratamente le superfici indicate con \triangle , cioè la superficie di centraggio dell'albero (1a) e la superficie interna del mozzo (1b). Inoltre occorre pulire ed oliare leggermente la superficie interna del calettatore (2a) e la superficie esterna del mozzo (2b), facendo in modo che l'olio non raggiunga le superfici già pulite e sgrassate (1a e 1b).

Before starting to mount the friction shrink disc, the surfaces indicated with \triangle , that is the shaft centring surface (1a) and the inside surface of the hub (1b), must be cleaned and degreased thoroughly. The inside surface of the shrink disc (2a) and the outside surface of the hub (2b) also need cleaning and oiling slightly, making sure the oil does not reach surfaces that have already been cleaned and degreased (1a and 1b).

Vor der Montage der Schrumpfscheibe müssen die mit \triangle gekennzeichneten Flächen, d.h. die Zentrierungsfläche der Welle (1a) und die Innenseite der Nabe (1b) gereinigt und sorgfältig entfettet werden. Außerdem die Innenseite der Schrumpfscheibe (2a) und die Außenseite der Nabe (2b) leicht ölen. Dabei darauf achten, dass die bereits gereinigten und entfetteten Flächen 1a und 1b nicht mit dem Öl in Berührung kommen.

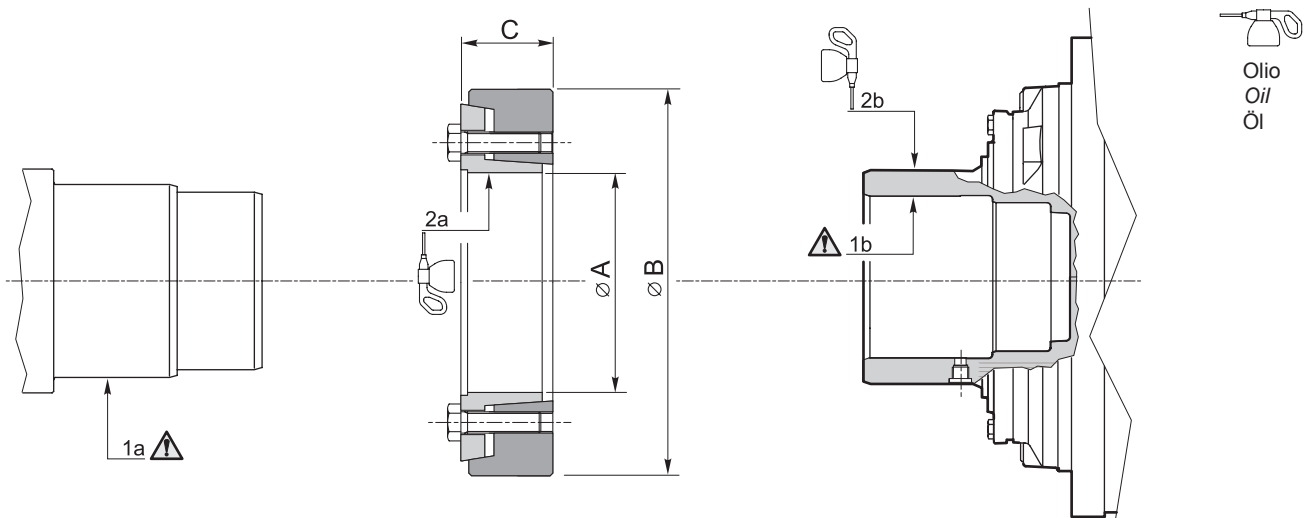

	A	B	C	Code
RR2500	165	290	69	154F6065
RR3200	185	320	86	154F6066
RR4000	185	320	86	154F6066
RR5200	185	320	86	154F6066
RR6500	220	370	106	154F6067
RR8000	240	405	110	154F6068
RR10000	240	405	110	154F6068
RR15000	280	460	136	154F6069
RR20000	300	485	144	154F6070
RR25000	340	570	159	154F6071
RR30000	360	590	167	154F6072
RR40000	360	590	167	154F6072
RR55000	390	650	170	154F6073

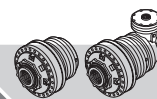

13.2 Frettes de serrage par frottement

Avant de monter la frette de serrage par frottement, nettoyer et dégraisser soigneusement les surfaces indiquées par un , c'est-à-dire la surface de centrage de l'arbre (1a) et la surface intérieure du moyeu (1b). De plus, il faut nettoyer et huiler légèrement la surface interne de la frette de serrage (2a) et la surface extérieure du moyeu (2b), en veillant à ce que l'huile n'atteigne pas les surfaces 1a et 1b déjà propres et dégraissées.

13.2 Engargoladores por fricción

Antes de proceder con el montaje del engargolador por fricción, es necesario limpiar y desengrasar cuidadosamente las superficies indicadas con , es decir la superficie de centrado del eje (1a) y la superficie interna del cubo (1b). Además, es necesario limpiar y aceitar ligeramente la superficie interna del engargolador (2a) y la superficie externa del cubo (2b), procurando que el aceite no alcance las superficies ya limpiadas y desengrasadas (1a y 1b).

13.2 Encaixadores por atrito

Antes de proceder à montagem do encaixador por atrito, é necessário limpar e desengordurar perfeitamente as superfícies indicadas com , ou seja, a superfície de centralização do veio (1a) e a superfície interna do cubo (1b). Além disso, é necessário limpar e olear ligeiramente a superfície interna do encaixador (2a) e a superfície externa do cubo (2b), fazendo de modo que o óleo não chegue às superfícies que já foram limpas e desengorduradas (1a e 1b).

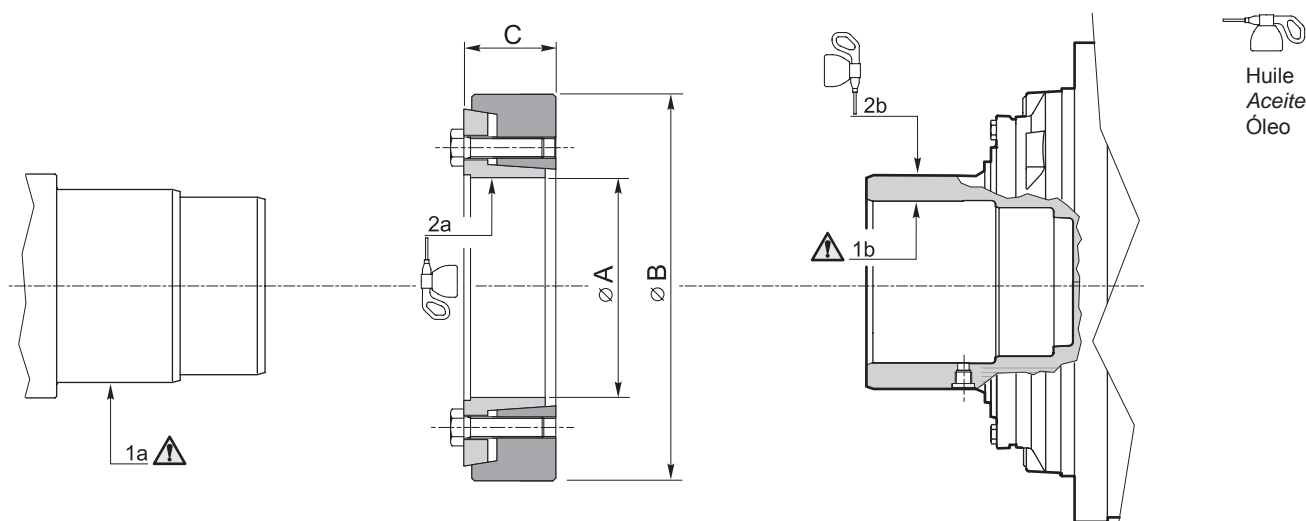

	A	B	C	Code
RR2500	165	290	69	154F6065
RR3200	185	320	86	154F6066
RR4000	185	320	86	154F6066
RR5200	185	320	86	154F6066
RR6500	220	370	106	154F6067
RR8000	240	405	110	154F6068
RR10000	240	405	110	154F6068
RR15000	280	460	136	154F6069
RR20000	300	485	144	154F6070
RR25000	340	570	159	154F6071
RR30000	360	590	167	154F6072
RR40000	360	590	167	154F6072
RR55000	390	650	170	154F6073

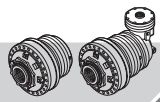

Solo in caso di disassemblaggio del calettatore e successivo montaggio, si dovrà provvedere a pulire ed ingrassare le superfici coniche del calettatore ed il gambo ed il sottotesta delle viti con grasso contenente additivi per alta pressione (MoS2).

Only if the shrink disc is removed and then remounted must its conical surfaces as well as the shank and underneath of the screws' heads be cleaned and greased using a grease containing high pressure additives (MoS2).

Nur beim Auseinanderbauen der Schrumpfscheibe und der anschließenden Montage müssen die Kegelflächen der Schrumpfscheibe, der Schaft und der Unterkopf der Schrauben sauber gemacht und mit Fett geschmiert werden, das Additive für Hochdruck (MoS2) enthält.

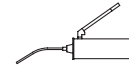
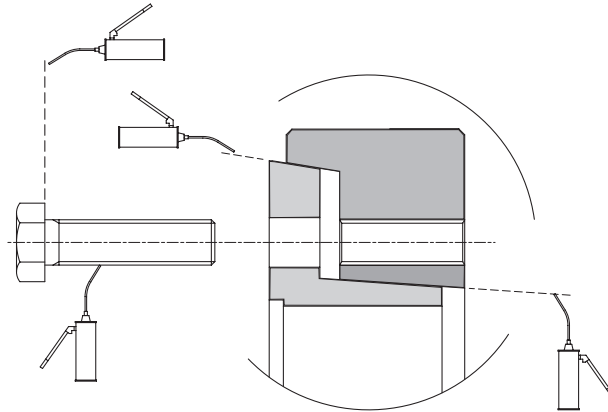

Grasso MoS2
MoS2 grease
Schmierfett MoS2

Per il serraggio delle viti si può procedere in due modi:

There are two ways the screws can be tightened:

Es gibt zwei Möglichkeiten, um die Schrauben anzuziehen:

1) serraggio senza chiave dinamometrica:

in questo caso occorre serrare le viti fin quando la quota H non è pari a zero;

1) without a torque wrench:

in this case tighten the screws until value H is zero;

1) Anziehen ohne Drehmomentschlüssel:

In diesem Fall die Schrauben anziehen, bis der Wert H ungleich Null ist;

2) serraggio con chiave dinamometrica:

in questo caso occorre serrare le viti al valore di coppia indicato in tabella.

2) with a torque wrench:

in this case tighten the screws to the torque value given in the table.

2) Anziehen mit Drehmomentschlüssel:

In diesem Fall die Schrauben mit dem in der Tabelle angegebenen Drehmoment anziehen.

In ogni caso occorre rispettare la quota M indicata in tabella.

In any case, observe value M given in the table.

In jedem Fall muss der in der Tabelle angegebene Wert M beachtet werden.

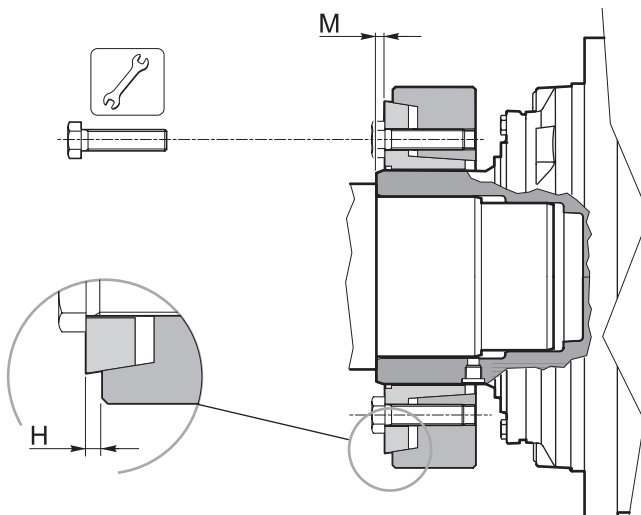

	M	H	 [Nm]
RR2500	7	0	290
RR3200	2	0	290
RR4000	2	0	290
RR5200	14	0	290
RR6500	18	0	570
RR8000	20	0	570
RR10000	20	0	570
RR15000	24	0	570
RR20000	21	0	990
RR25000	28	0	990
RR30000	20	0	990
RR40000	20	0	990
RR55000	35	0	1480

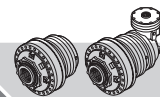

FR ES PT

Seulement en cas de désassemblage de la frette de serrage et montage successif, il faudra nettoyer et graisser les surfaces coniques de la frette de serrage ainsi que la tige et le collet des vis avec de la graisse contenant des additifs pour haute pression (MoS2).

Sólo en caso de desmontaje del engargolador y sucesivo montaje, habrá que proceder a limpiar y desengrasar las superficies cónicas del engargolador y el cuerpo y la parte de debajo de las cabezas de los tornillos con grasa que contenga aditivos para alta presión (MoS2).

Somente no caso de desmontagem e sucessiva montagem do encaixador, se deve limpar e lubrificar as superfícies cônicas do encaixador e a haste e a parte inferior da cabeça dos parafusos com graxa contendo aditivos para alta pressão (MoS2).

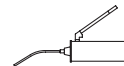
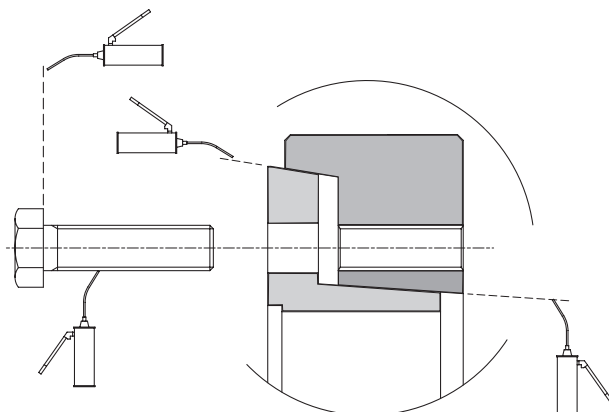

Graisse MoS2
Grasa MoS2
Graxa MoS2

Pour le serrage des vis, il est possible de procéder de deux manières:

Para el apriete de los tornillos se puede proceder de dos maneras:

Para o aperto dos parafusos pode-se proceder de dois modos:

1) par un serrage sans clef dynamométrique:

dans ce cas, il faut serrer les vis jusqu'à ce que la cote H soit à zéro;

1) apriete sin llave dinamométrica:

en este caso es necesario apretar los tornillos hasta que la cota H es igual que cero;

1) torque sem chave dinamométrica:

neste caso é necessário apertar os parafusos até que a cota H seja igual a zero;

2) par un serrage avec clef dynamométrique:

dans ce cas, il faut serrer les vis à la valeur de couple indiquée sur le tableau.

2) apriete con llave dinamométrica:

en este caso es necesario apretar los tornillos con el valor de par indicado en la tabla.

2) torque com chave dinamométrica:

neste caso é necessário apertar os parafusos ao valor de cópia indicado na tabela.

Quel que soit le type de serrage, il faut toujours respecter la cote M indiquée sur le tableau.

En todo caso es necesario respetar la cota M indicada en la tabla.

Em todo o caso é necessário respeitar a cota M indicada na tabela.

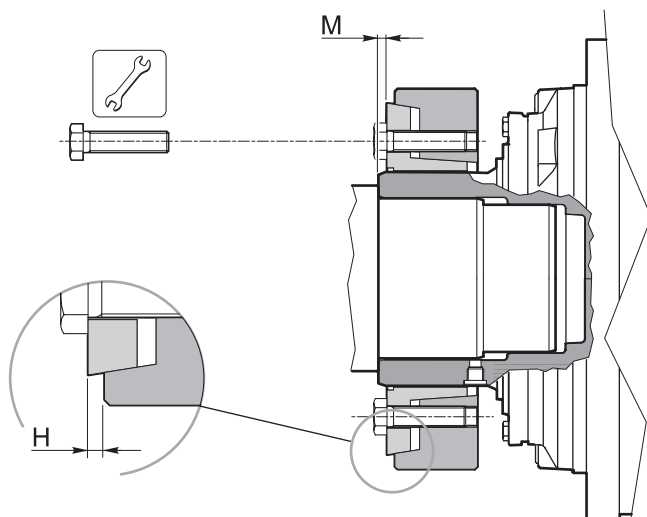

	M	H	 [Nm]
RR2500	7	0	290
RR3200	2	0	290
RR4000	2	0	290
RR5200	14	0	290
RR6500	18	0	570
RR8000	20	0	570
RR10000	20	0	570
RR15000	24	0	570
RR20000	21	0	990
RR25000	28	0	990
RR30000	20	0	990
RR40000	20	0	990
RR55000	35	0	1480

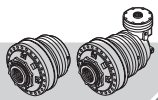

13.3 Bracci di reazione

Di seguito sono indicate le dimensioni suggerite per la realizzazione dei bracci di reazione, da utilizzare in abbinamento al calettatore per attrito, nel caso di riduttore con uscita tipo MH.

Nel caso di braccio di reazione a singolo fulcro, si raccomanda di rispettare tassativamente la quota H_{min} , indicata in tabella, e l'angolo di 90° .

Prima del montaggio occorre pulire e sgrassare i piani di battuta e le superfici di centraggio, che devono essere esenti da verniciatura.

13.3 Torque arms

Below are the dimensions recommended for implementing the torque arms, to use in combination with the friction shrink disc for reduction gears with an MH type output.

In the case of a single-fulcrum torque arm, it is essential to respect the H_{min} value, indicated in the table, and the 90° angle.

Before mounting, clean and degrease the resting tops and centring surfaces, which must be free from paint.

13.3 Reaktionsarme

Es folgt eine Auflistung der Abmessungen, die für die Realisierung der Reaktionsarme empfohlen werden, welche in Kombination mit der Schrumpfscheibe bei Planetengetrieben mit Ausgang MH verwendet werden.

Bei Reaktionsarmen mit nur einem Hebelrehpunkt müssen der in der Tabelle angegebene Wert H_{min} und ein Winkel von 90° strikt beachtet werden.

Vor der Montage müssen die Auflageflächen und die Zentrierungsflächen gereinigt und entfettet werden. Sicherstellen, dass sie keine Lackreste aufweisen.

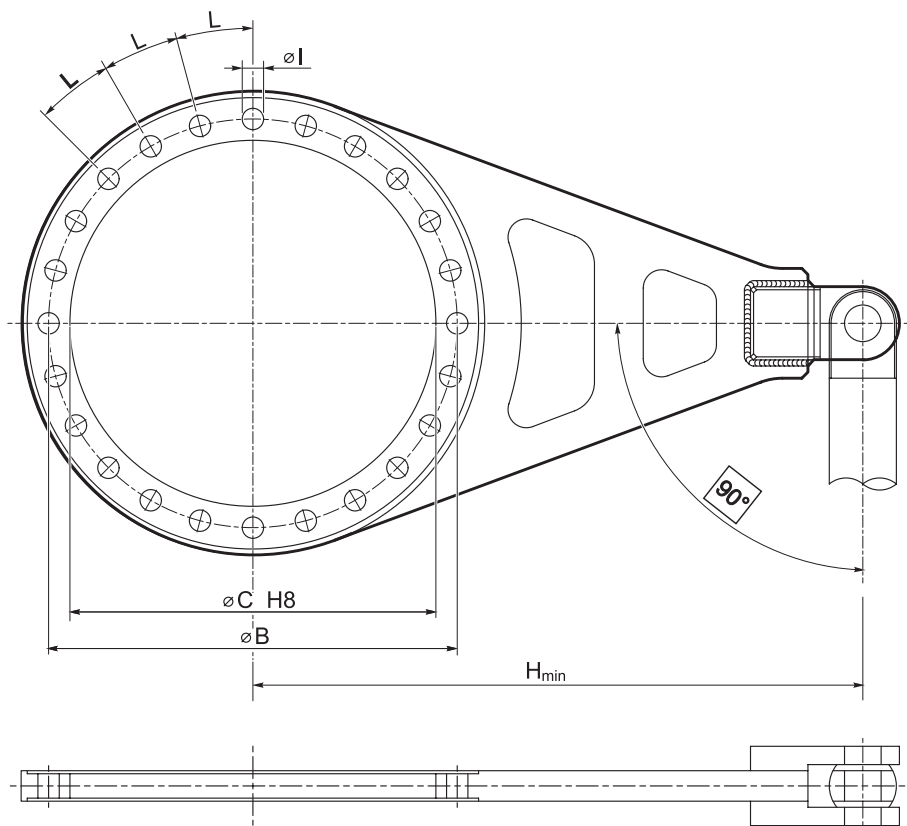

	B	C	H_{min}	I	L
RR2500	335	300	500	17.5 n°24	15°
RR3200	370	335	600	17.5 n°24	15°
RR4000	420	380	600	17.5 n°32	11.25°
RR5200	420	380	700	17.5 n°32	11.25°
RR6500	465	415	800	22 n°32	11.25°
RR8000	515	460	900	26 n°32	11.25°
RR10000	515	460	900	26 n°32	11.25°
RR15000	590	535	1000	26 n°32	11.25°
RR20000	665	605	1100	26 n°36	10°
RR25000	750	675	1300	33 n°36	10°
RR30000	830	750	1500	33 n°36	10°
RR40000	830	750	1500	33 n°36	10°
RR55000	920	830	1700	39 n°36	10°

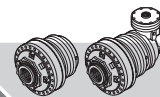

13.3 Bras de torsion

Ci-après figurent les dimensions recommandées pour la réalisation des bras de torsion, à utiliser en association avec la frette de serrage par frottement, en cas de réducteur avec sortie type MH.

En cas de bras de torsion à un pivot, il est fortement conseillé de respecter la cote H_{min} , indiquée sur le tableau, et l'angle de 90° .

Avant le montage, nettoyer et dégraisser les plans de butée et les surfaces de centrage, qui doivent être dépourvues de toute trace de peinture.

13.3 Brazos de reacción

A continuación se indican las medidas aconsejadas para realizar los brazos de reacción, a utilizar en combinación con el engargolador por fricción, en el caso de reductor con salida de tipo MH.

En el caso de brazo de reacción con fulcro individual, se recomienda respetar tajantemente la cota H_{min} , indicada en la tabla, y el ángulo de 90° .

Antes de efectuar el montaje es necesario limpiar y desengrasar los planos de contacto y las superficies de centrado, que no deben tener pintura.

13.3 Braços de reação

A seguir estão indicadas as dimensões sugeridas para a realização dos braços de reação, a utilizar juntamente com o encaixador por atrito, no caso de redutor com saída tipo MH.

No caso de braço de reação de fulcro único, recomenda-se respeitar absolutamente a cota H_{min} , indicada na tabela, e o ângulo de 90° .

Antes da montagem é necessário limpar e desengordurar os planos de contato e as superfícies de centralização, que devem ser isentas de pintura.

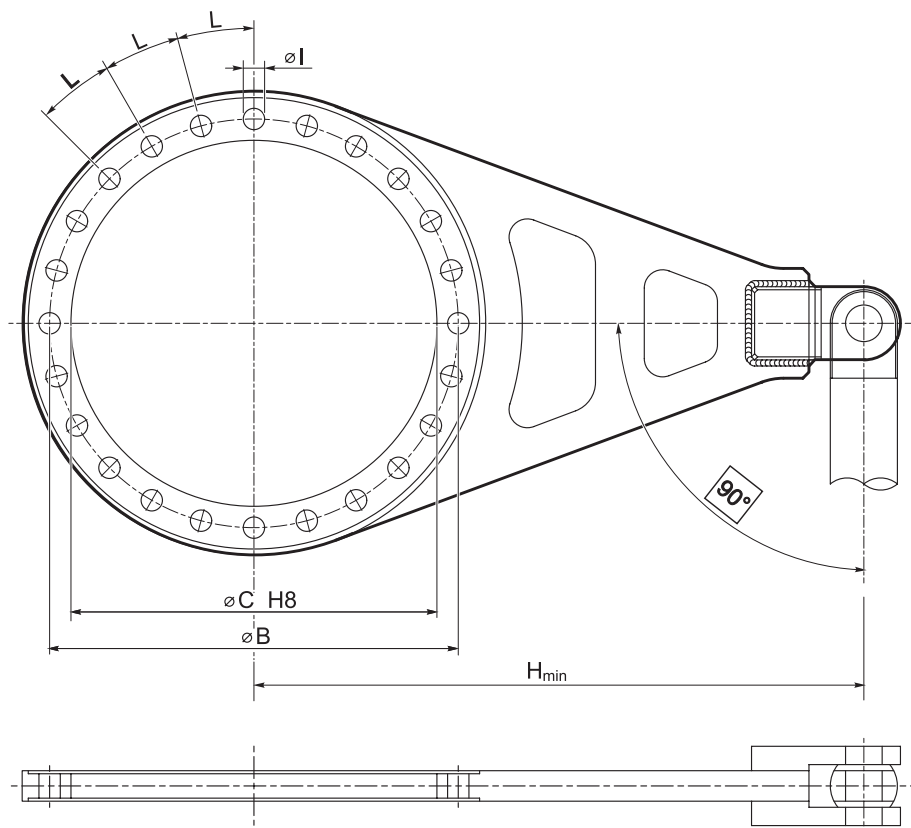

	B	C	H_{min}	I	L
RR2500	335	300	500	17.5 n°24	15°
RR3200	370	335	600	17.5 n°24	15°
RR4000	420	380	600	17.5 n°32	11.25°
RR5200	420	380	700	17.5 n°32	11.25°
RR6500	465	415	800	22 n°32	11.25°
RR8000	515	460	900	26 n°32	11.25°
RR10000	515	460	900	26 n°32	11.25°
RR15000	590	535	1000	26 n°32	11.25°
RR20000	665	605	1100	26 n°36	10°
RR25000	750	675	1300	33 n°36	10°
RR30000	830	750	1500	33 n°36	10°
RR40000	830	750	1500	33 n°36	10°
RR55000	920	830	1700	39 n°36	10°

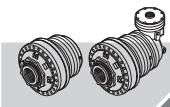

Le istruzioni per la selezione dei riduttori contenute nel presente catalogo sono puramente indicative.

Si prega di contattare il Servizio Tecnico Reggiana Riduttori per una selezione ottimale dei riduttori e per le necessarie verifiche aggiuntive.

Reggiana Riduttori si riserva la facoltà di modificare, senza alcun preavviso, i dati tecnici o dimensionali contenuti nel presente catalogo, allo scopo di migliorare il prodotto.

E' vietata la riproduzione totale o parziale del presente catalogo, senza autorizzazione scritta da parte di Reggiana Riduttori s.r.l.

Les instructions utiles au choix des réducteurs sont données, sur ce catalogue, à titre purement indicatif.

Contactez le Service Technique Reggiana Riduttori pour choisir les réducteurs correspondant le mieux à vos besoins et pour les contrôles complémentaires indispensables.

Reggiana Riduttori se réserve le droit de modifier, sans avis préalable, les caractéristiques techniques ou dimensionnelles figurant sur ce catalogue, dans le but d'améliorer le produit.

La reproduction totale ou partielle de ce catalogue est interdite sans autorisation écrite de la part de Reggiana Riduttori s.r.l.

The instructions for selecting the reduction gears in this catalogue are purely indicative. Please contact the Reggiana Riduttori Technical Service for the best selection of the reduction gears and for the necessary additional checks.

Reggiana Riduttori reserves the right to change, without prior notice, the technical or dimensional data in this catalogue with the purpose of improving the product.

It is forbidden to reproduce this catalogue, totally or partially, without written authorisation from Reggiana Riduttori s.r.l.

Las instrucciones para la selección de los reductores presentadas en este catálogo son puramente indicativas.

Se ruega contactar con el Servicio Técnico de Reggiana Riduttori para una selección óptima de los reductores y para las necesarias comprobaciones adicionales.

Reggiana Riduttori se reserva la facultad de modificar, sin previo aviso, los datos técnicos o dimensionales presentados en este catálogo, a fin de mejorar el producto.

Se prohíbe la reproducción, total o parcial, del presente catálogo, sin previa autorización por escrito de Reggiana Riduttori s.r.l.

Bei den Hinweisen zur Auswahl der Planetengetriebe im vorliegenden Katalog handelt es sich um reine Anhaltswerte.

Für eine optimale Auswahl der Planetengetriebe und die erforderlichen zusätzlichen Prüfungen halten Sie bitte mit dem Technischen Kundendienst von Reggiana Riduttori Rücksprache.

Die Firma Reggiana Riduttori behält sich das Recht vor, jederzeit und ohne Vorankündigung die technischen Daten und Abmessungen, die im vorliegenden Katalog angegeben sind, zu ändern in der Absicht, das Produkt zu verbessern.

Die Wiedergabe des vorliegenden Katalogs oder Teilen davon ohne vorherige schriftliche Genehmigung durch die Firma Reggiana Riduttori S.r.l. ist verboten.

As instruções relativas à selecção dos reductores contidas no presente catálogo são fornecidas a título meramente informativo.

Agredecemos que contactem o Serviço Técnico Reggiana Riduttori para a selecção ótima dos reductores e posteriores verificações.

Reggiana Riduttori reserva-se a facultade de modificar, sem obrigação de pré aviso, os dados técnicos o as dimensões contidas no presente catálogo, com o objectivo de melhorar o produto.

É proibida a reprodução total ou parcial do presente catálogo, sem prévia autorização escrita da parte da Reggiana Riduttori S.r.l.

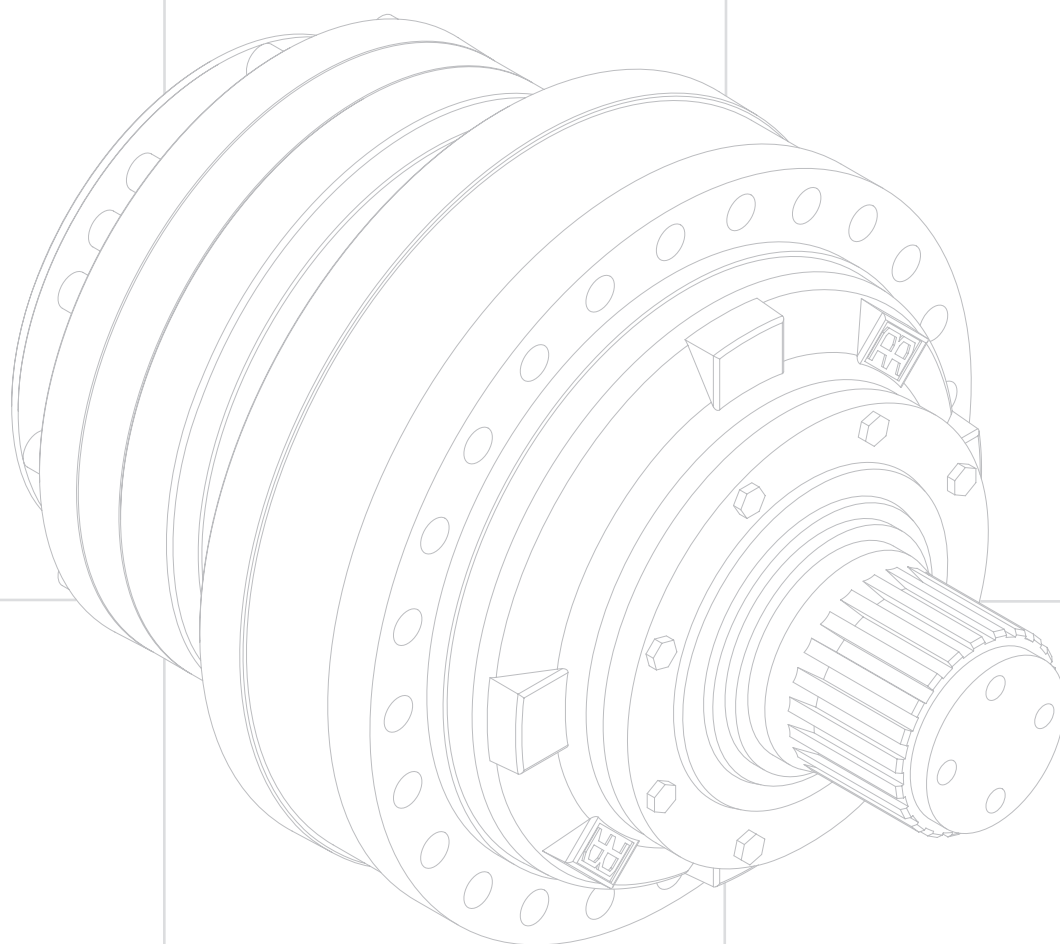

C201-1200-00



COMPANY WITH
QUALITY SYSTEM
CERTIFIED BY DNV
= ISO 9001 =



REGGIANA RIDUTTORI S.r.l.

Via Martiri di Marzabotto,7
42020 S. Polo d'Enza (RE) ITALY
tel. +39.0522.259111 - fax +39.0522.874321
info@reggianariduttori.com
www.reggianariduttori.com